

Neurons and Perception

March 17, 2009

John Maunsell

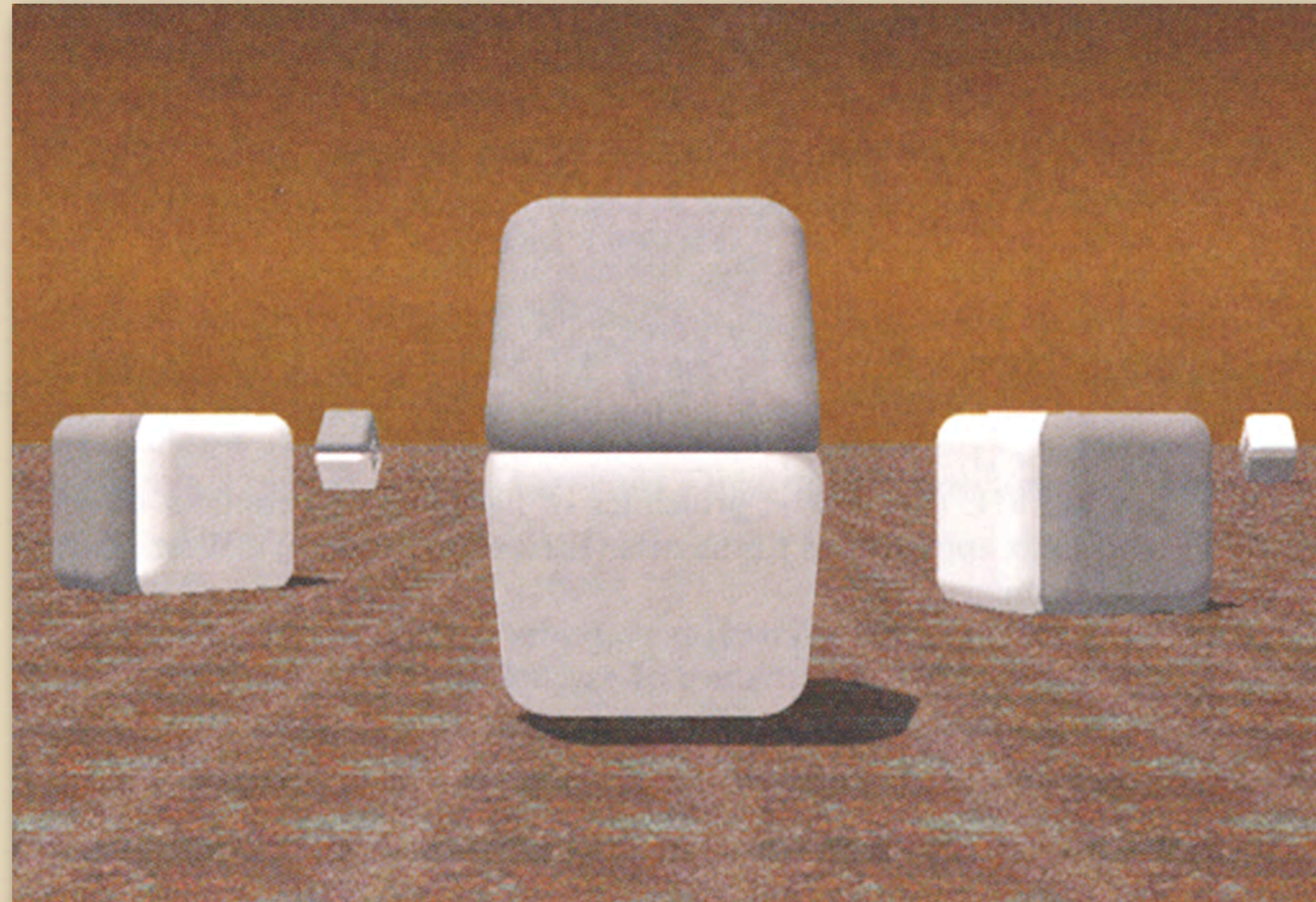

Maier, A., Wilke, M., Aura, C., Zhu, C., Ye, F.Q., Leopold, D.A. (2008) Divergence of fMRI and neural signals in V1 during perceptual suppression in the awake monkey. *Nature Neuroscience* 11:1193-1200.

Monkey visual cortex

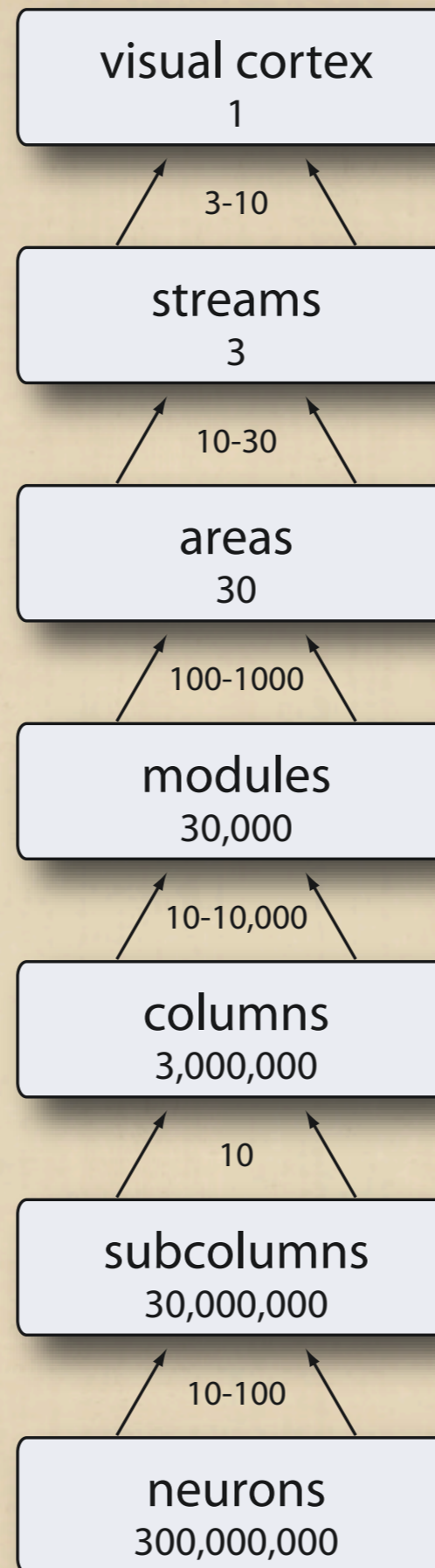

Purves 2002
www.purveslab.net

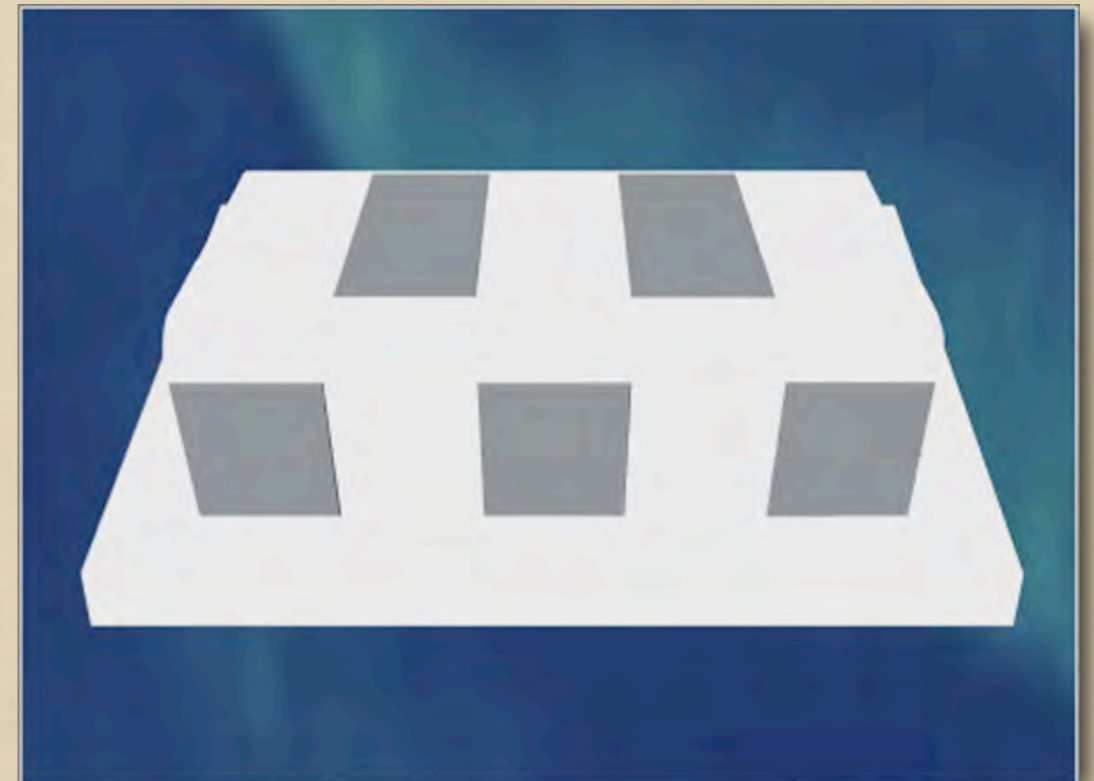
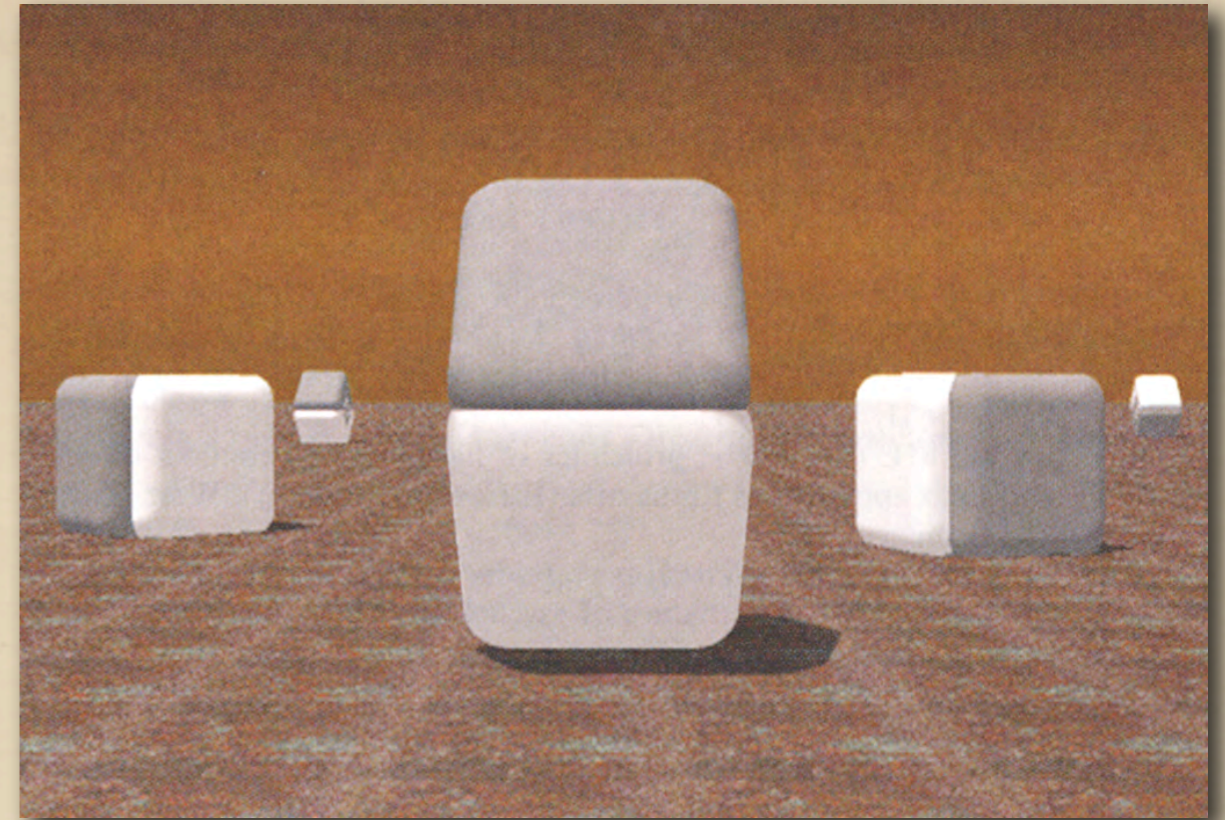
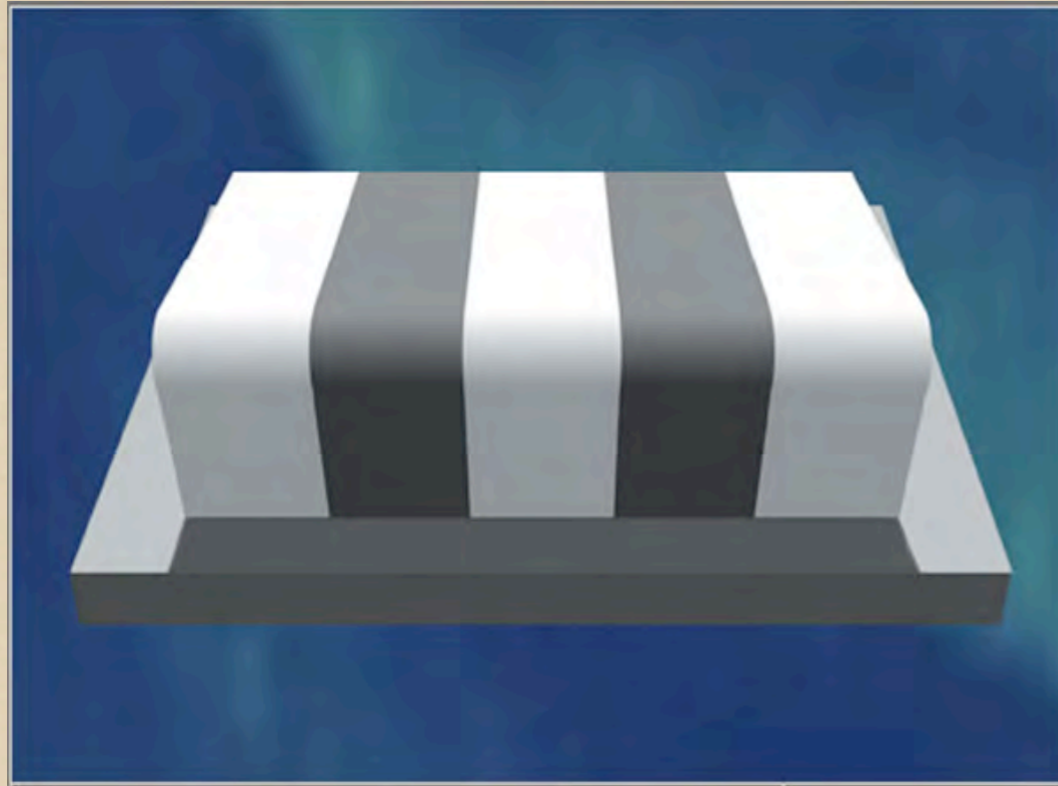

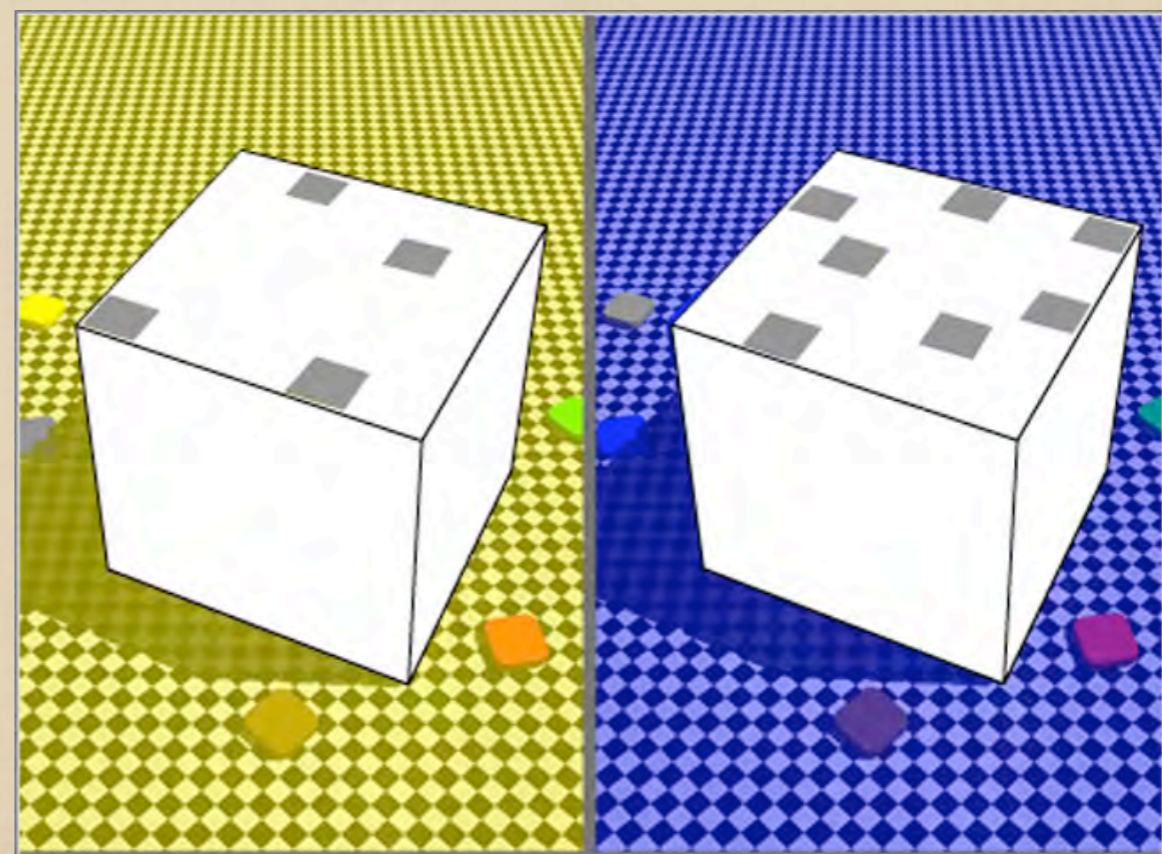
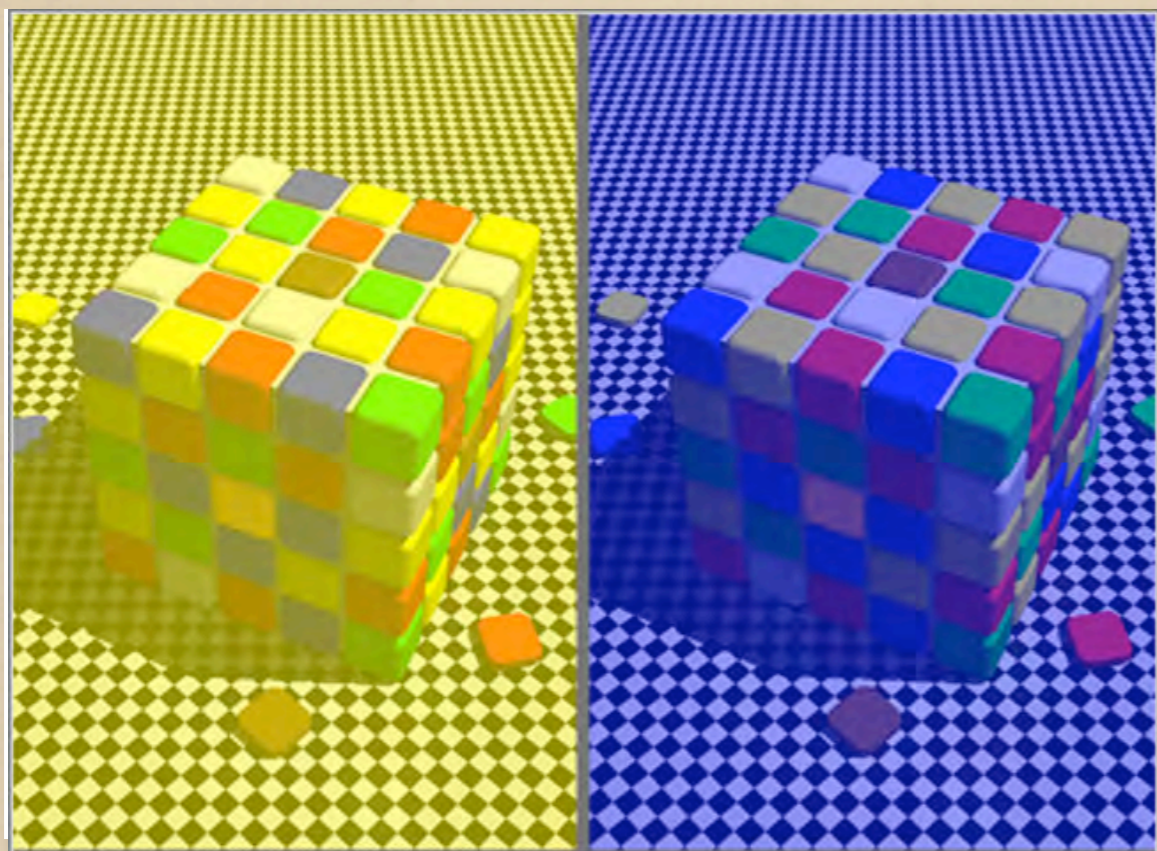

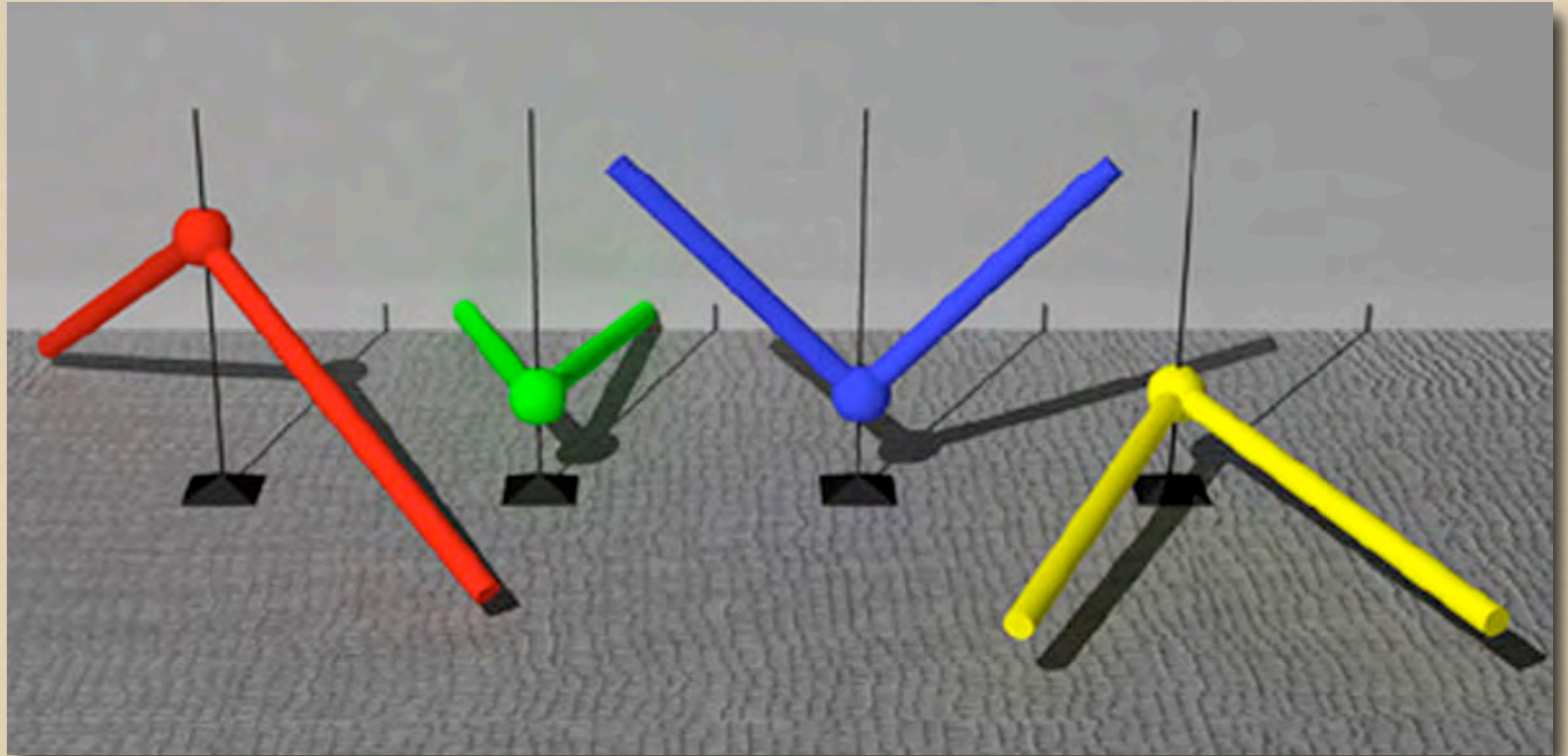

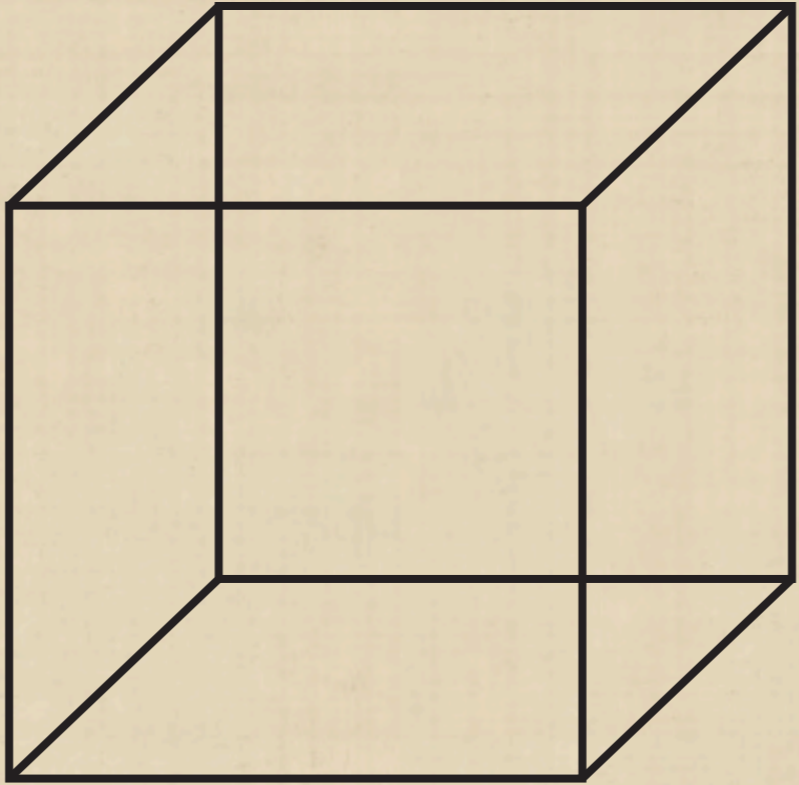

Periphery:
neuronal sampling

Starlight

Relative
photon
flux

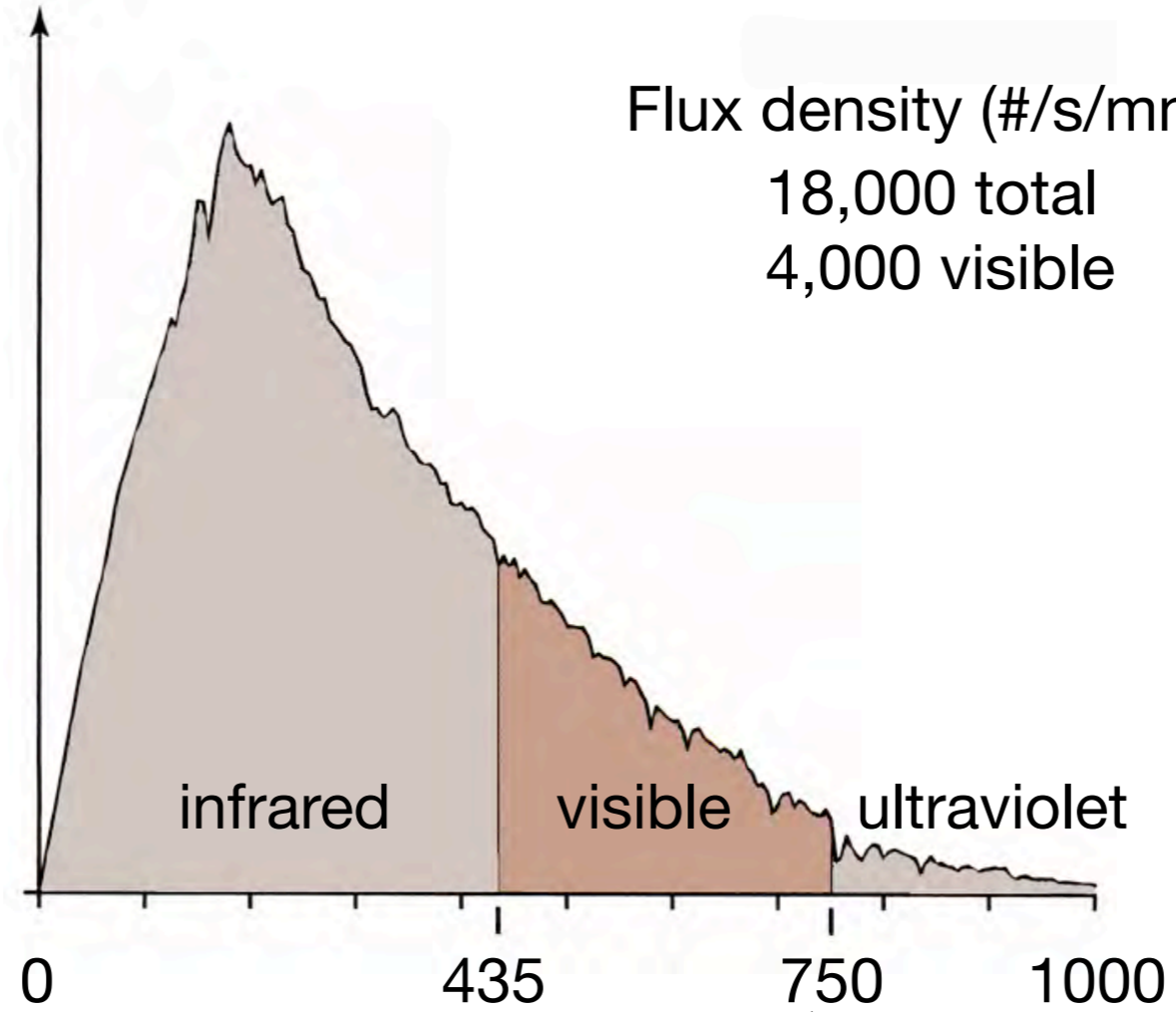

Frequency (THz)

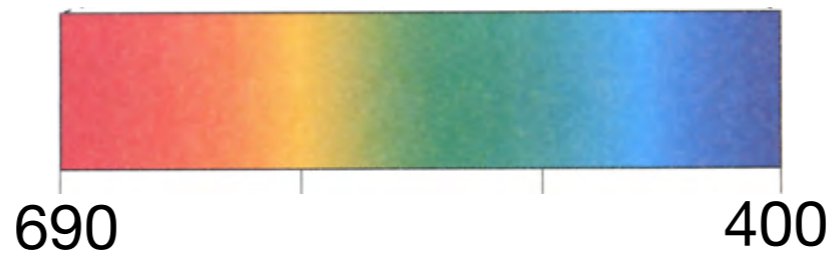

Wavelength (nm)

Midget and Parasol Retinal Ganglion Cells

Watanabe & Rodieck, 1989

Midget

1.0 mm



3.2 mm



5.6 mm



Parasol

1.0 mm



3.1 mm



5.8 mm

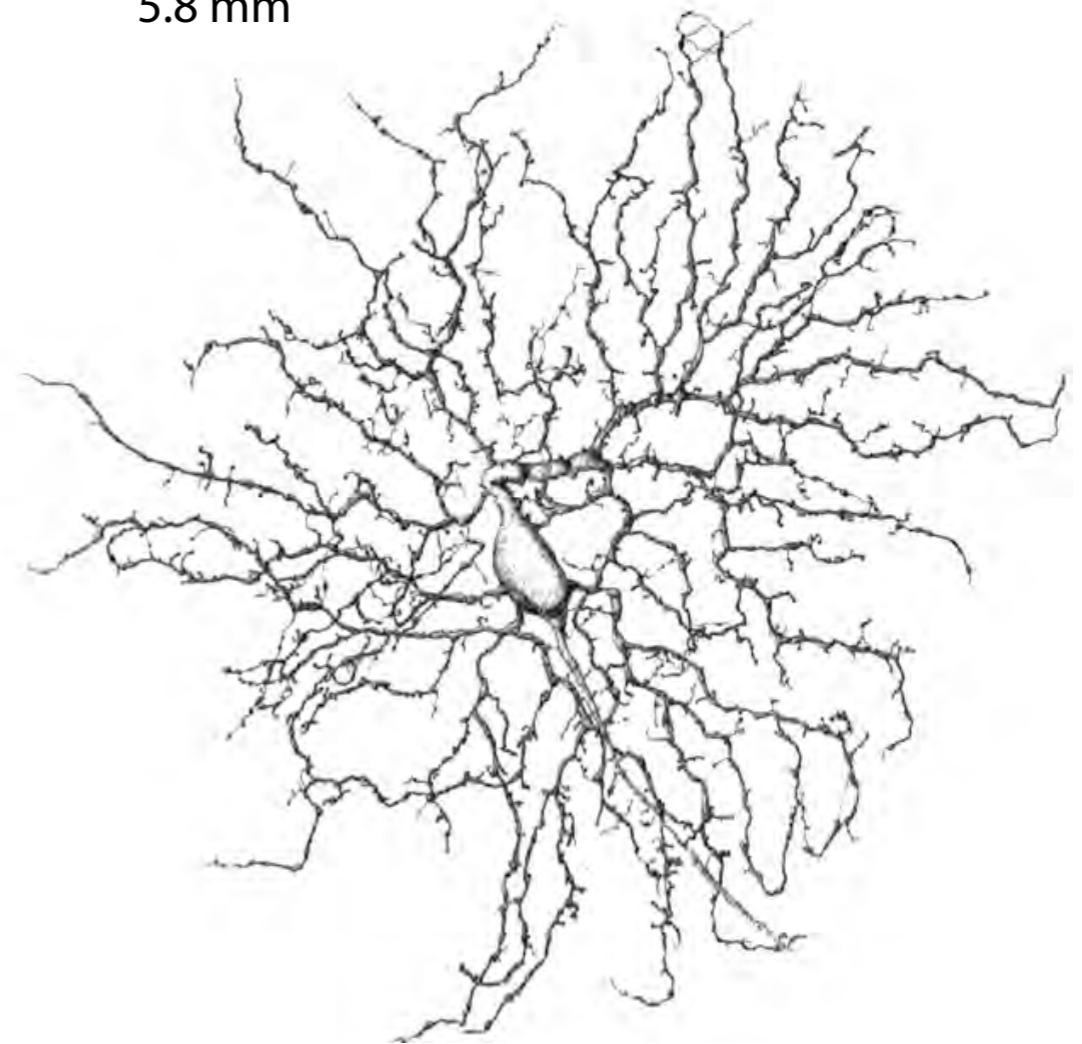

Sinusoidal Gratings

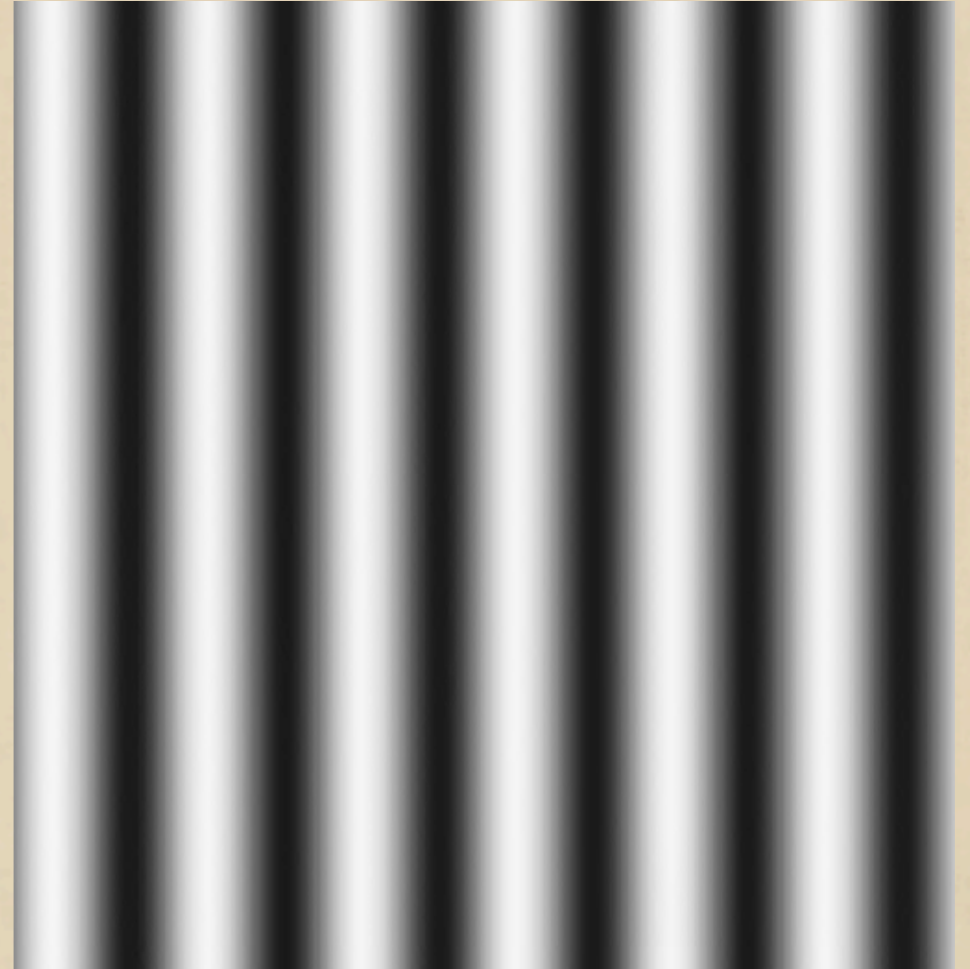
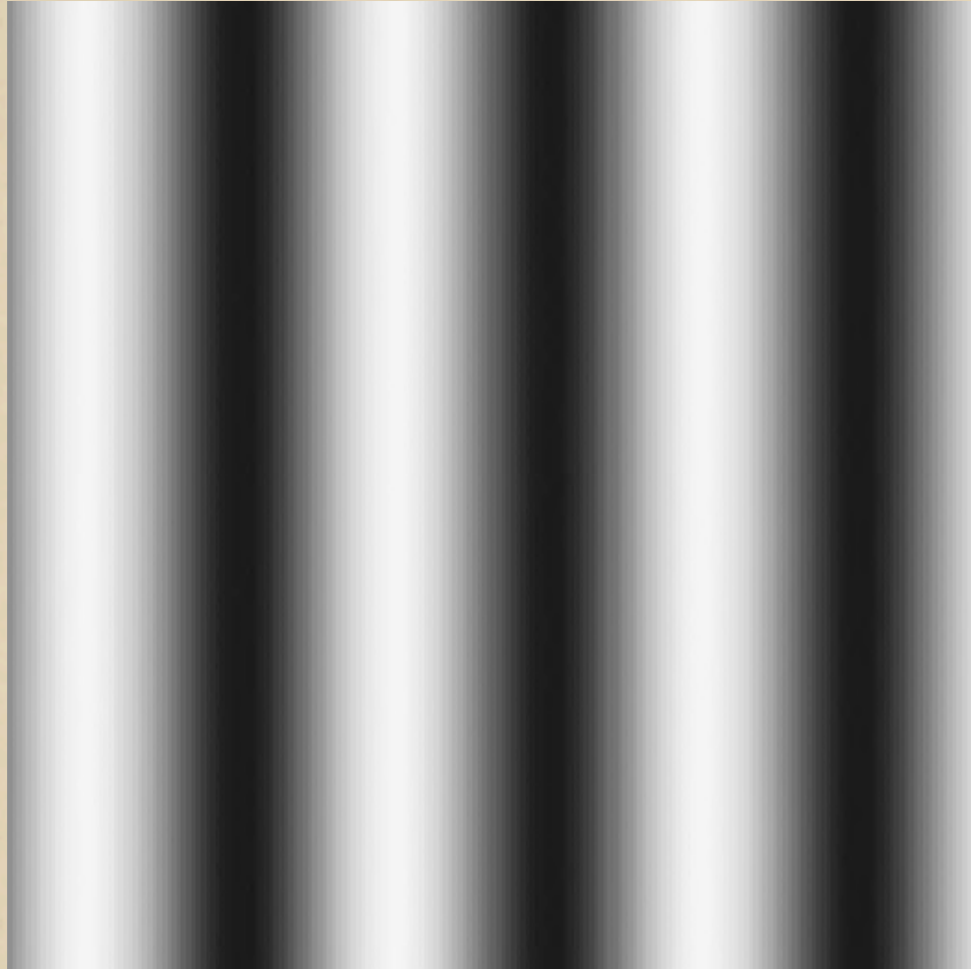

Monkey visual acuity

Merigan & Katz, 1990

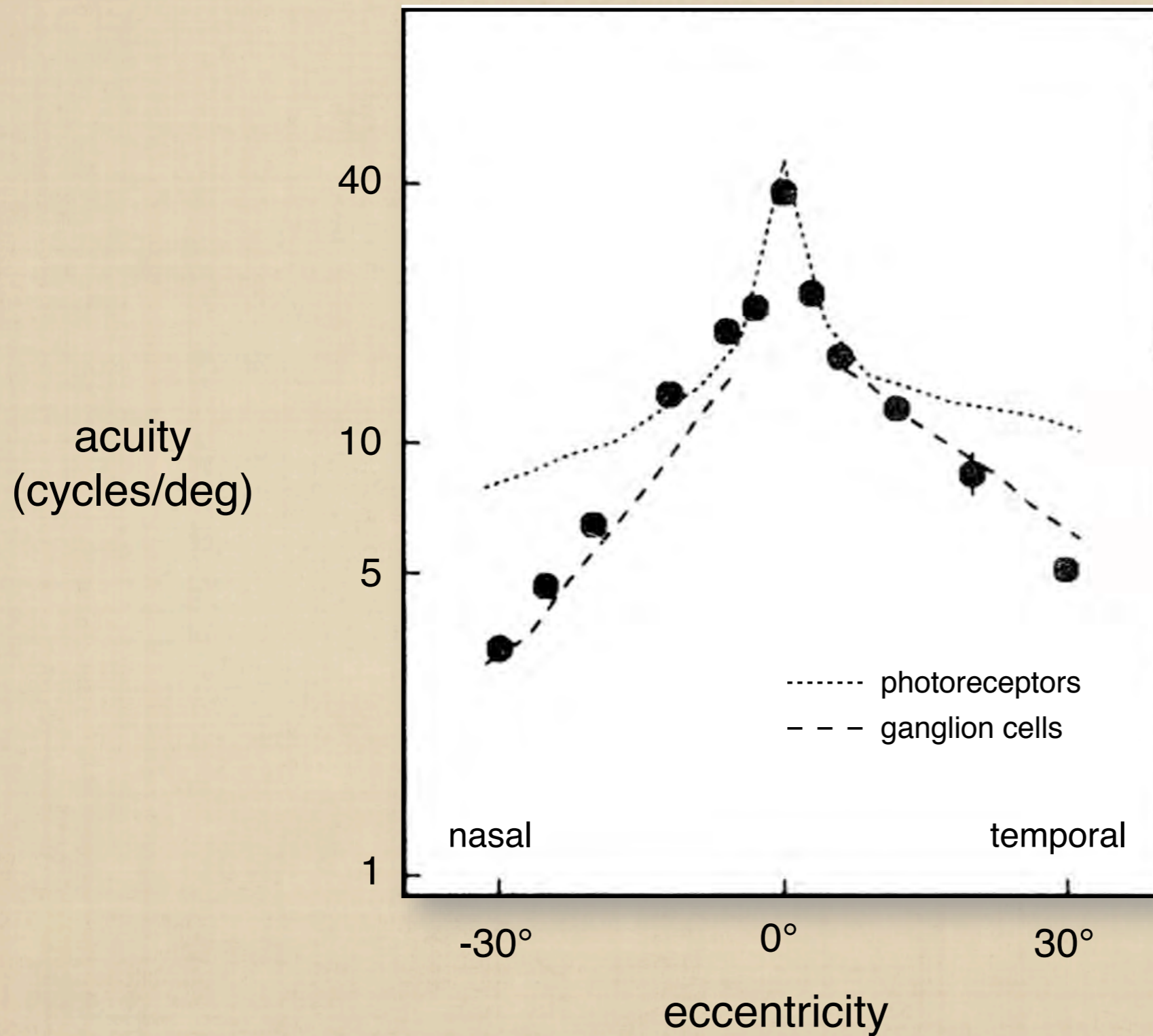

400
receptors

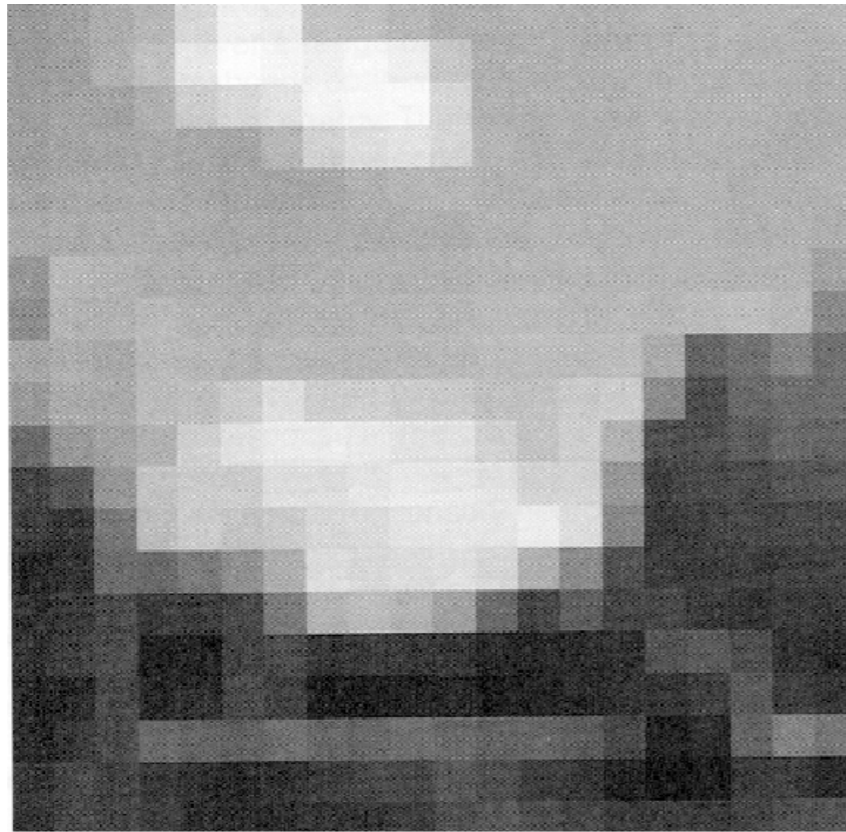

3,600
receptors



14,400
receptors

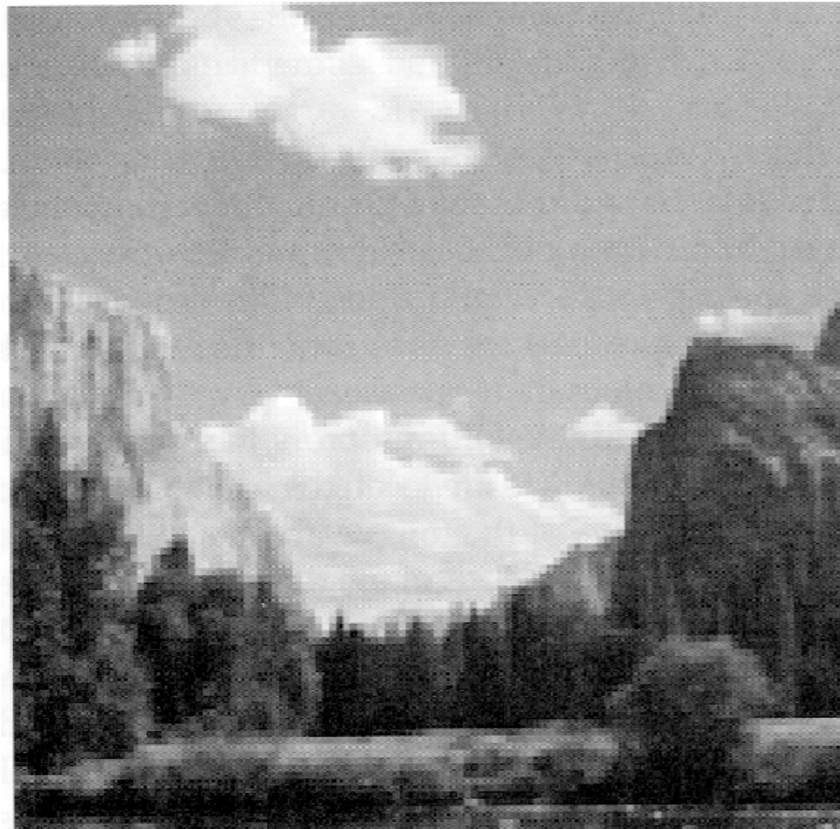

160,000
receptors

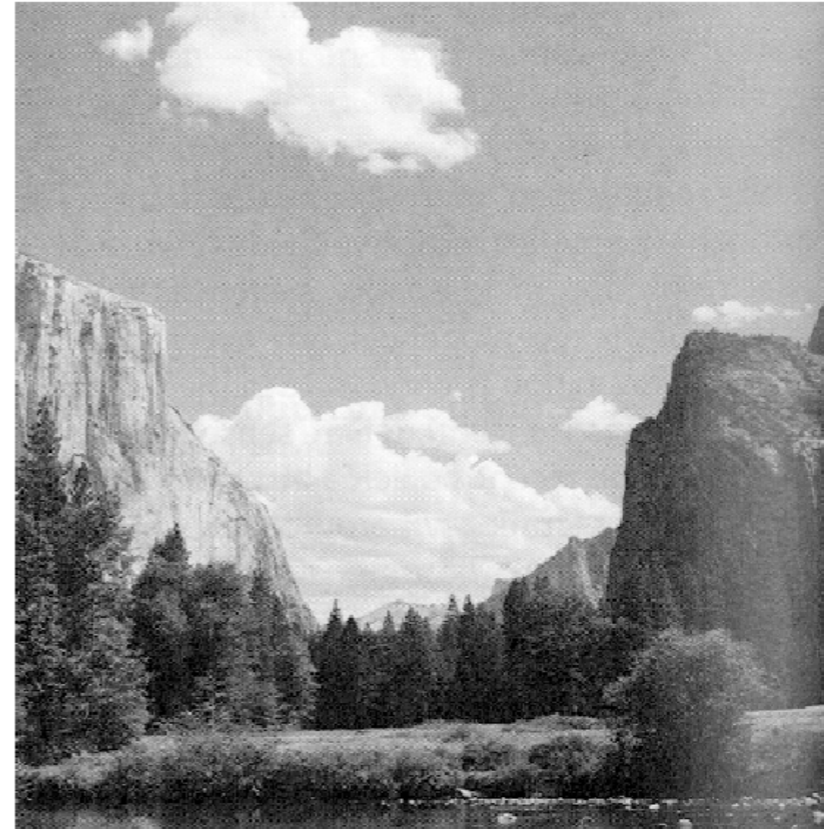

Periphery:
neuronal sampling
neuronal sensitivity

Detection of weak flashes

Hecht et al., 1942

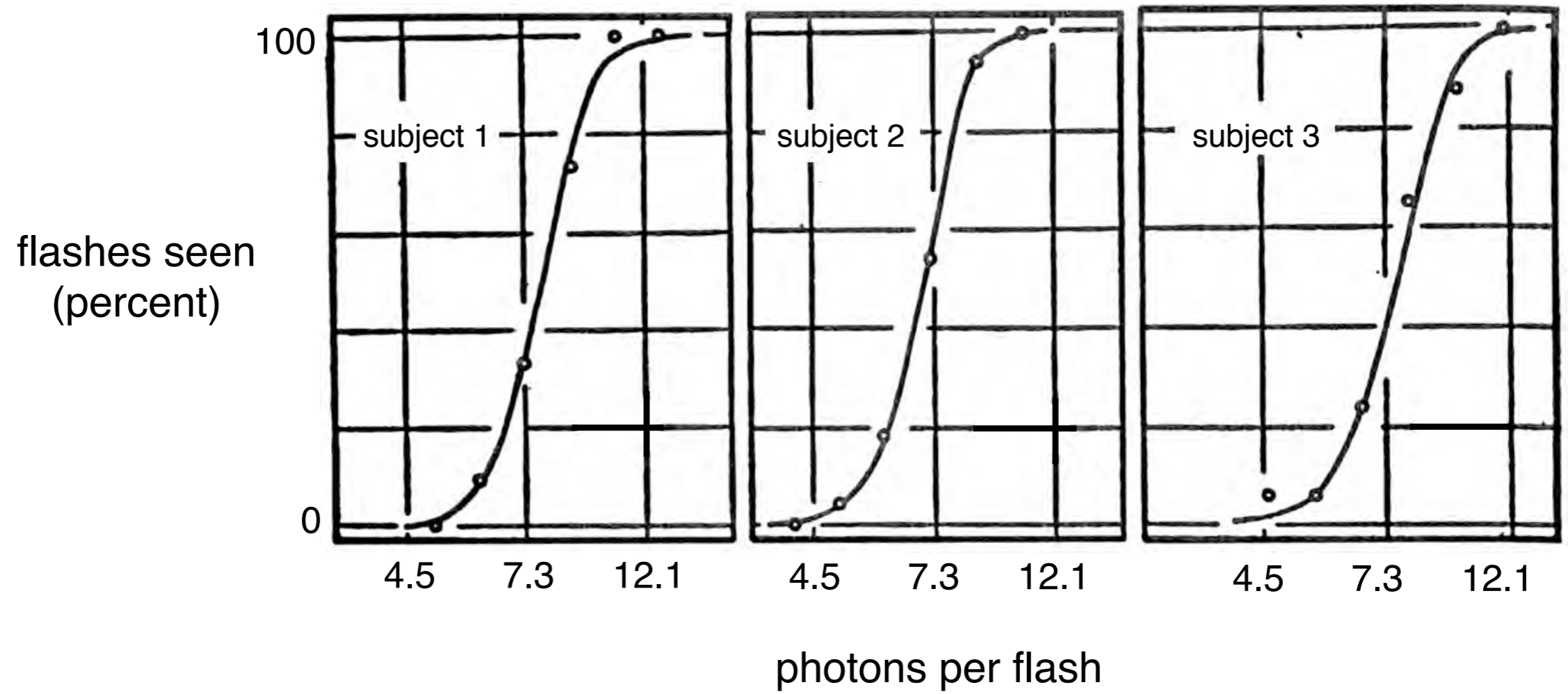

Response of Limulus optic fiber to weak flashes

Hartline et al., 1947

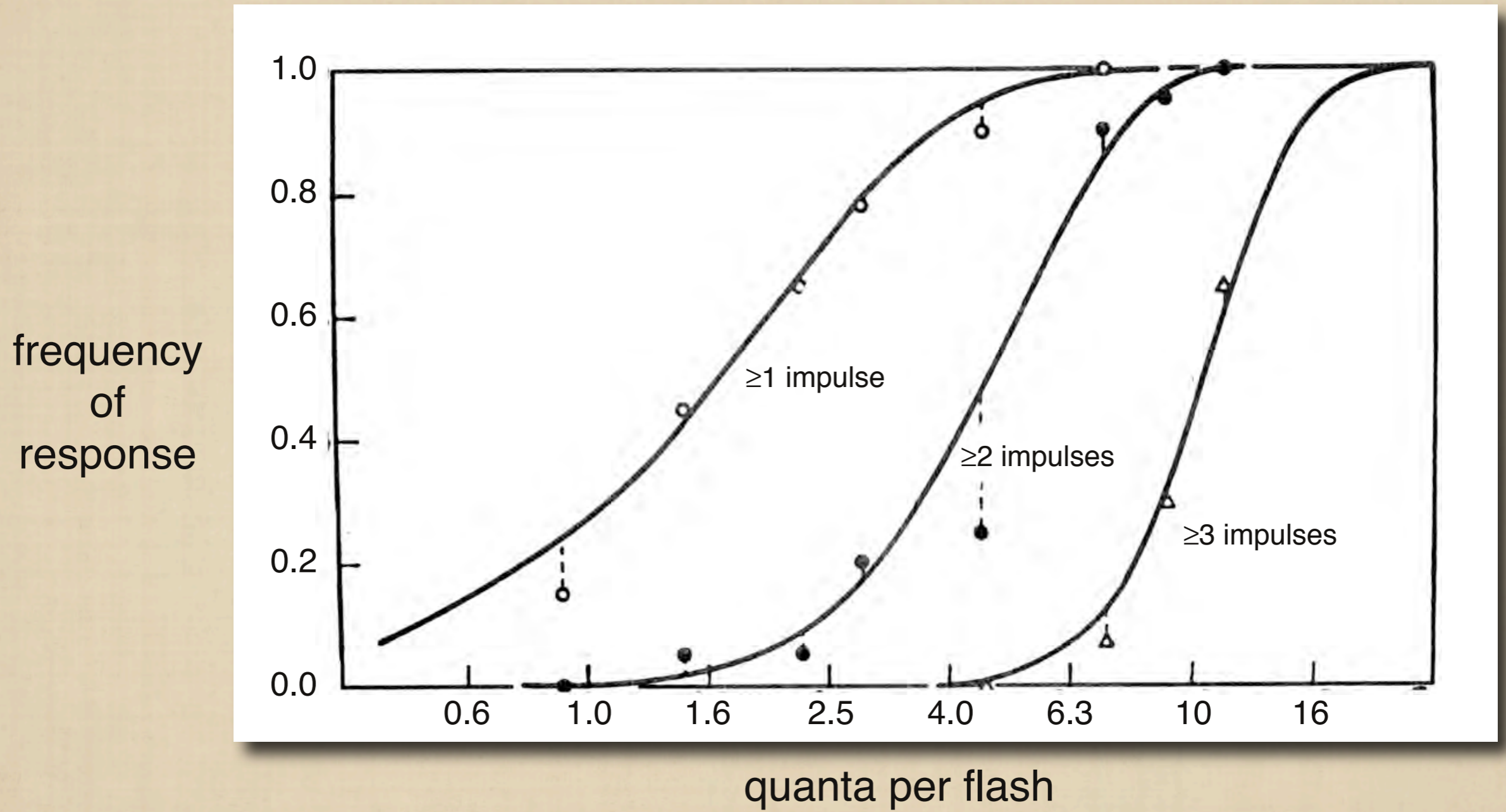

Neuronal and behavioral detection of skin indentation

Vallbo & Johansson 1976

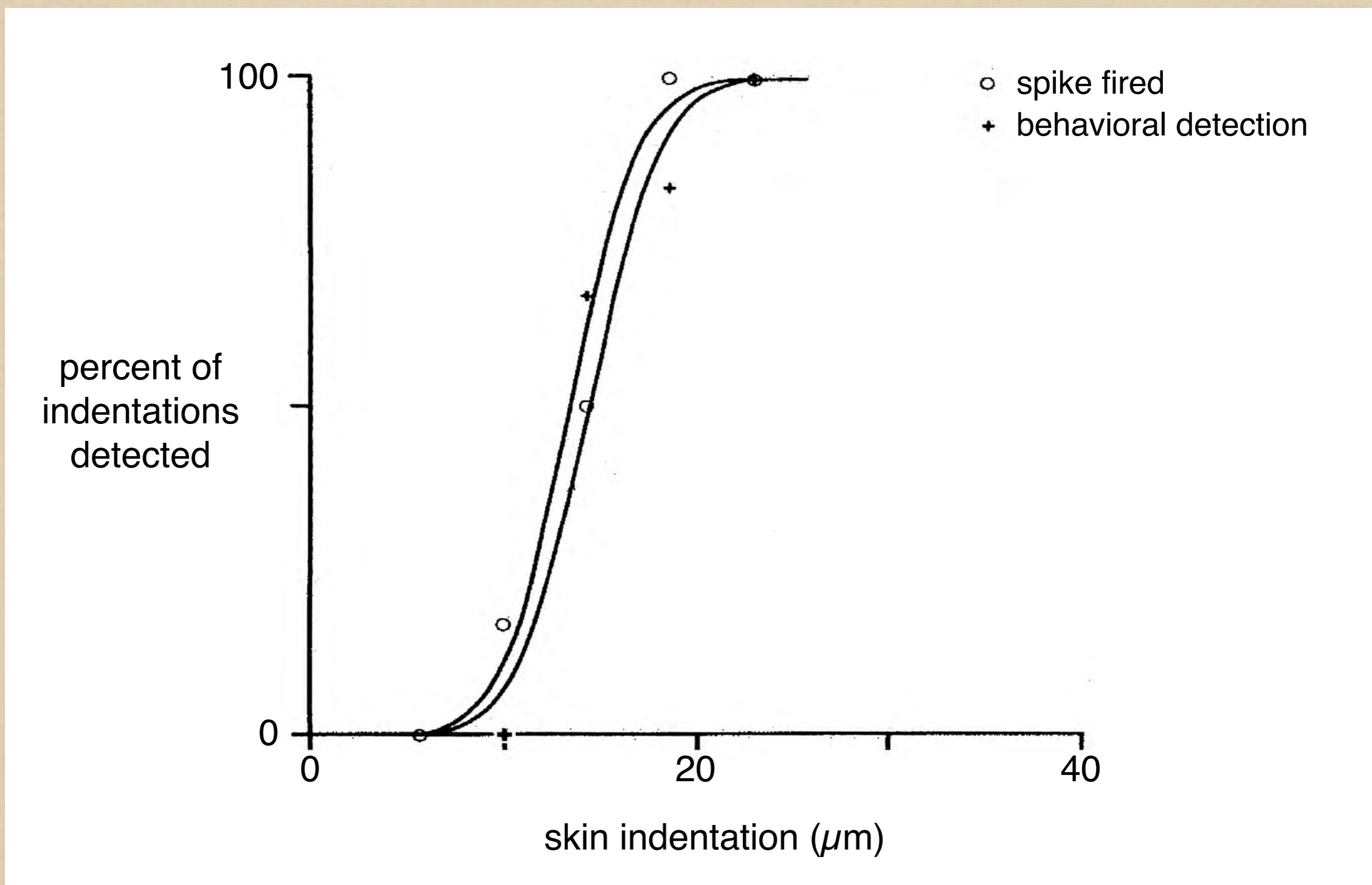



Neuronal and Behavioral Detection

Mountcastle et al. 1972

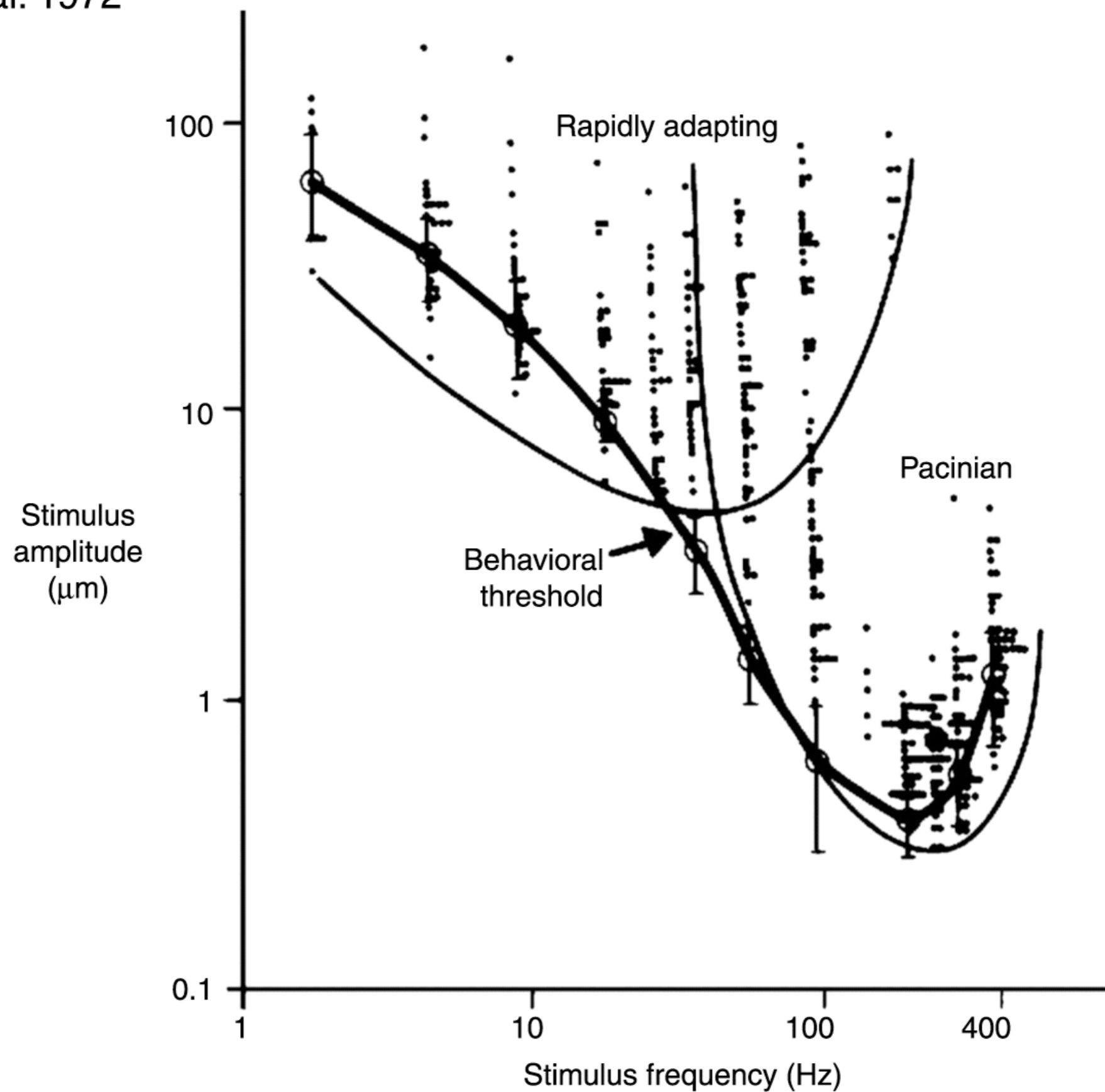

Parietal Pathway

Temporal Pathway

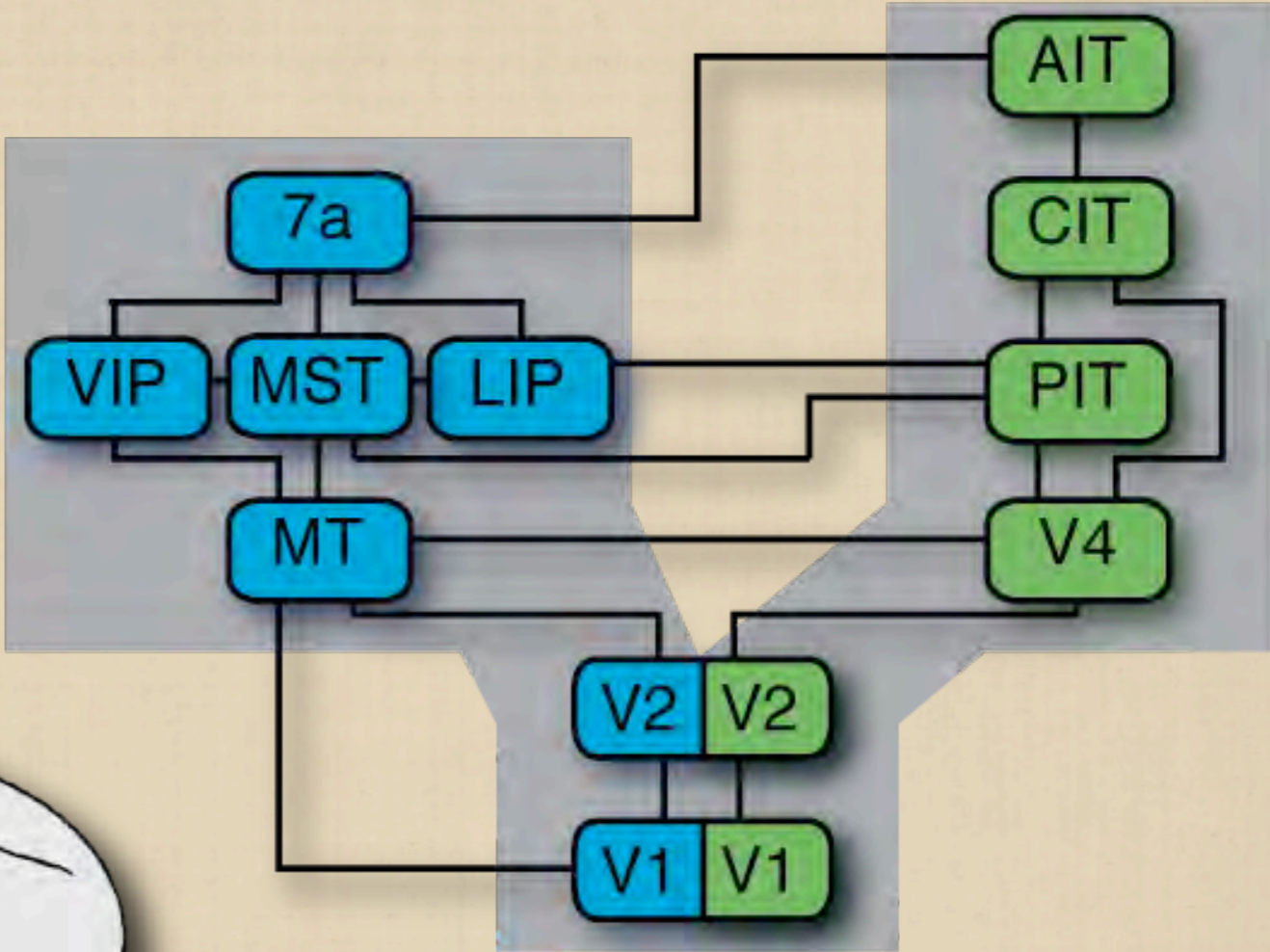

Parietal Pathway

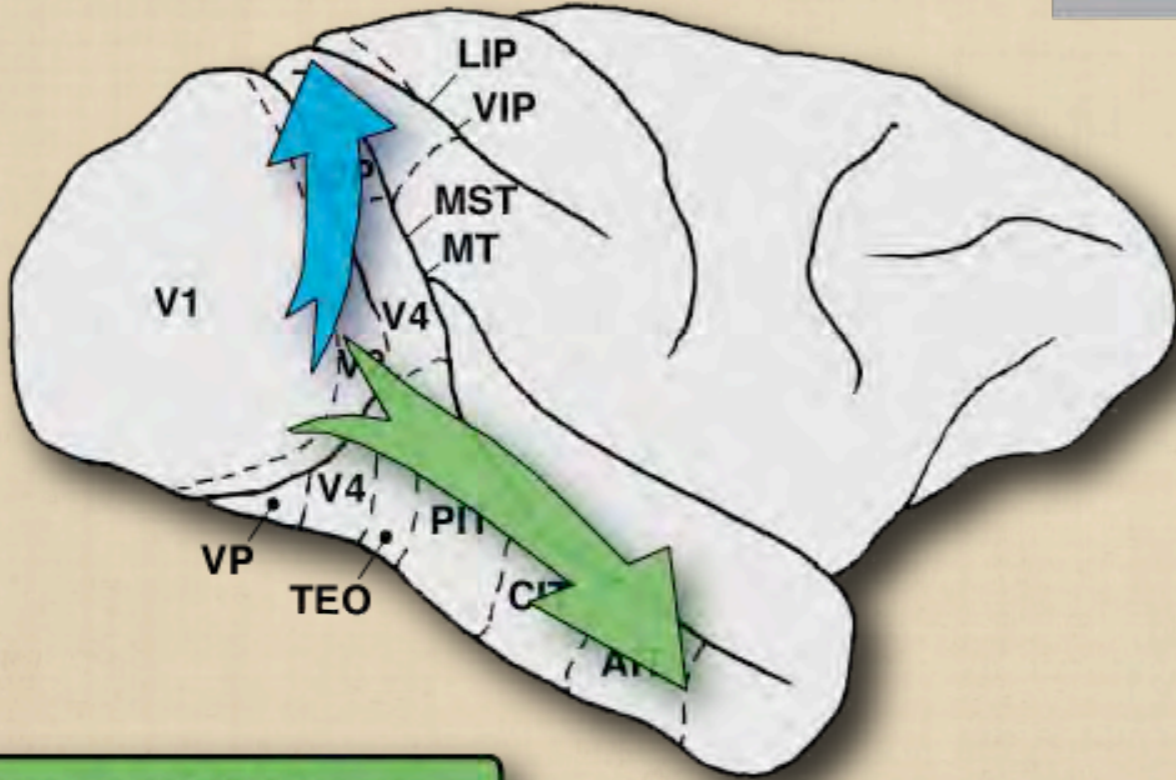

Temporal Pathway

Dynamic random dot motion

Motion coherence

0.0

0.5

1.0

Direction Discrimination Task

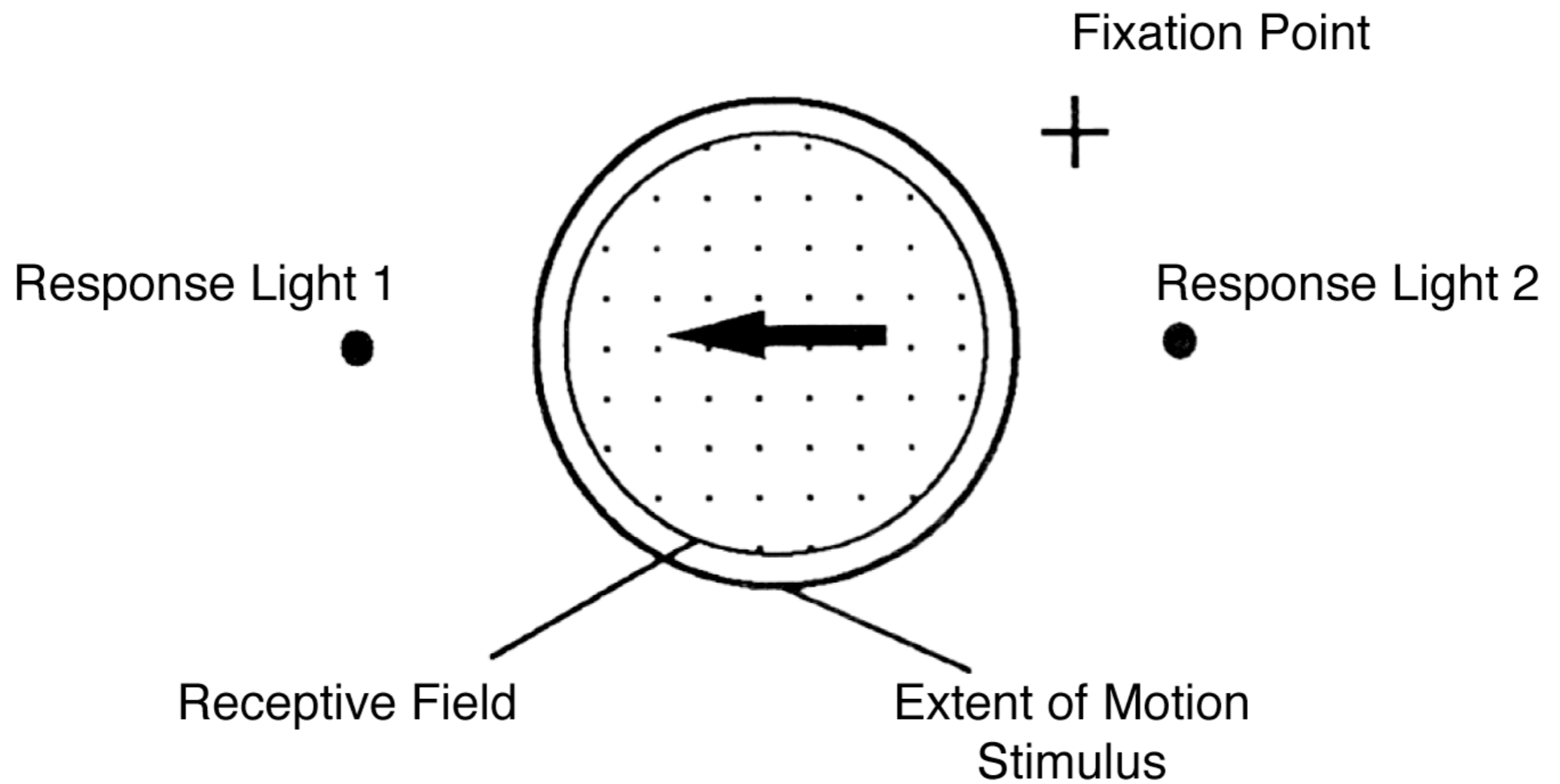

Periphery:

correlation with neuronal sampling
correlation with neuronal sensitivity

Central:

selective effects of ablation

Monkey vision after unilateral lesion in MT

Newsome & Paré, 1988

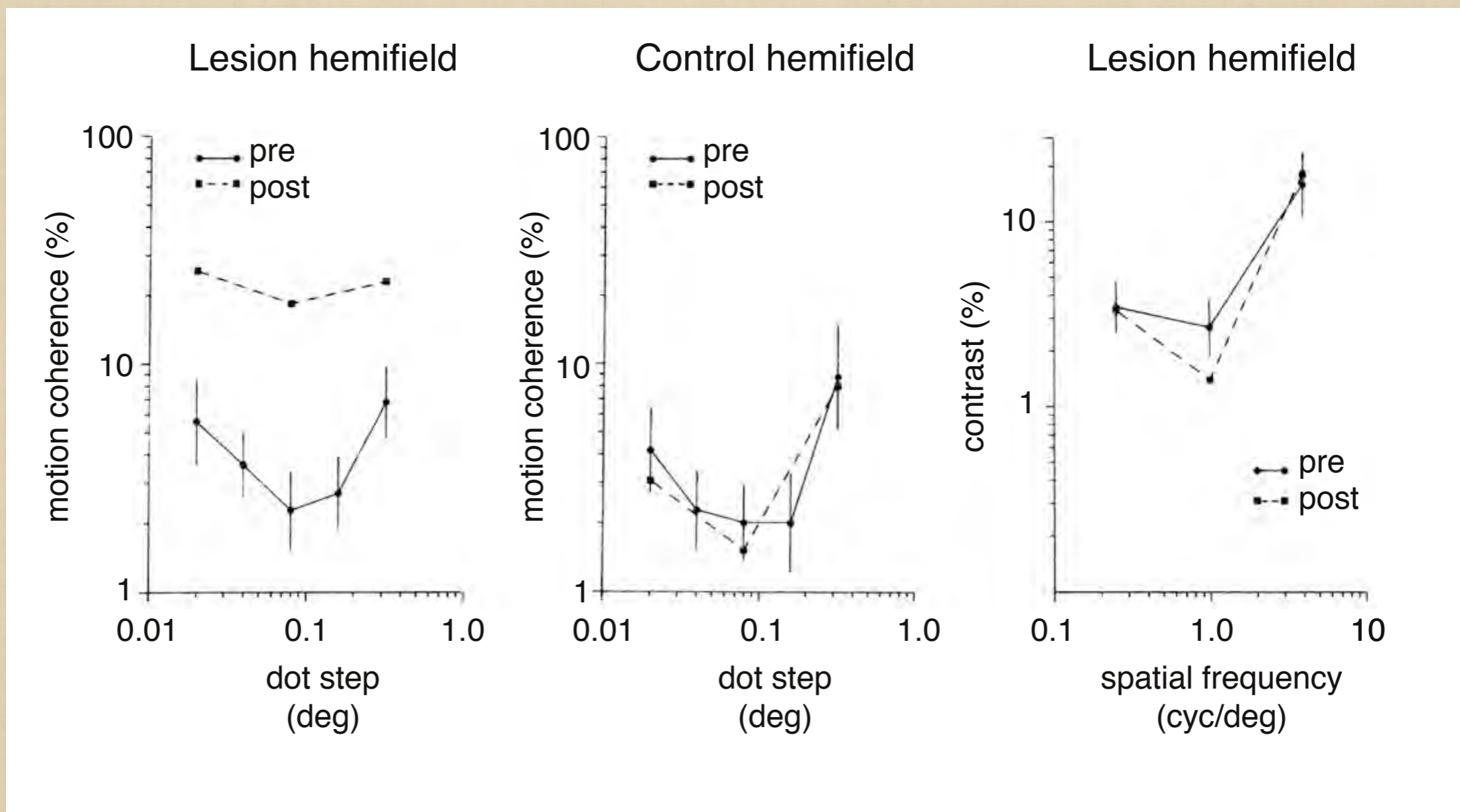

Periphery:

correlation with neuronal sampling
correlation with neuronal sensitivity

Central:

selective effects of ablation
selective effects of microstimulation

Effect of MT microstimulation on reported direction

Salzman et al. 1992

Percent reported
in
preferred direction

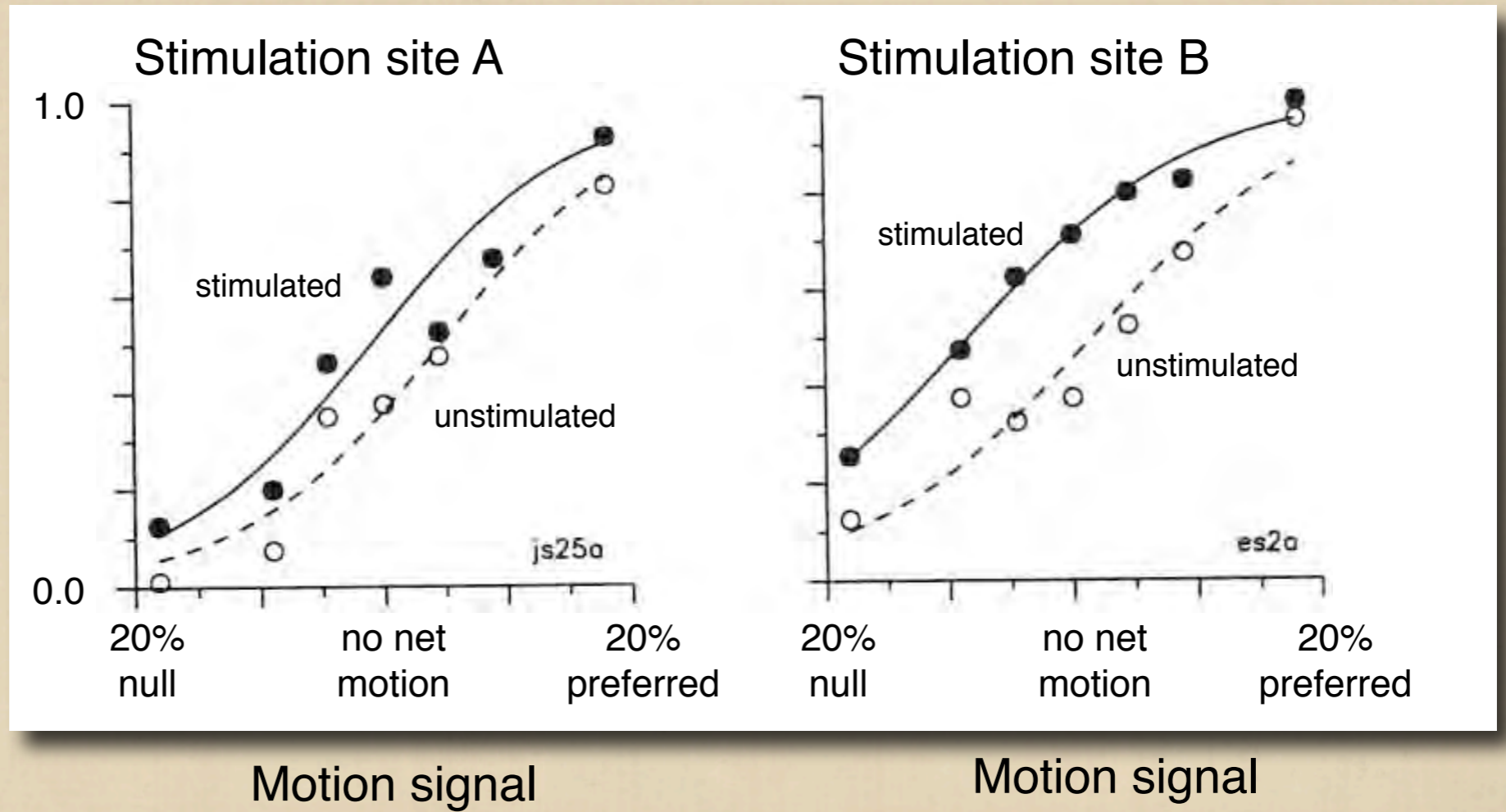

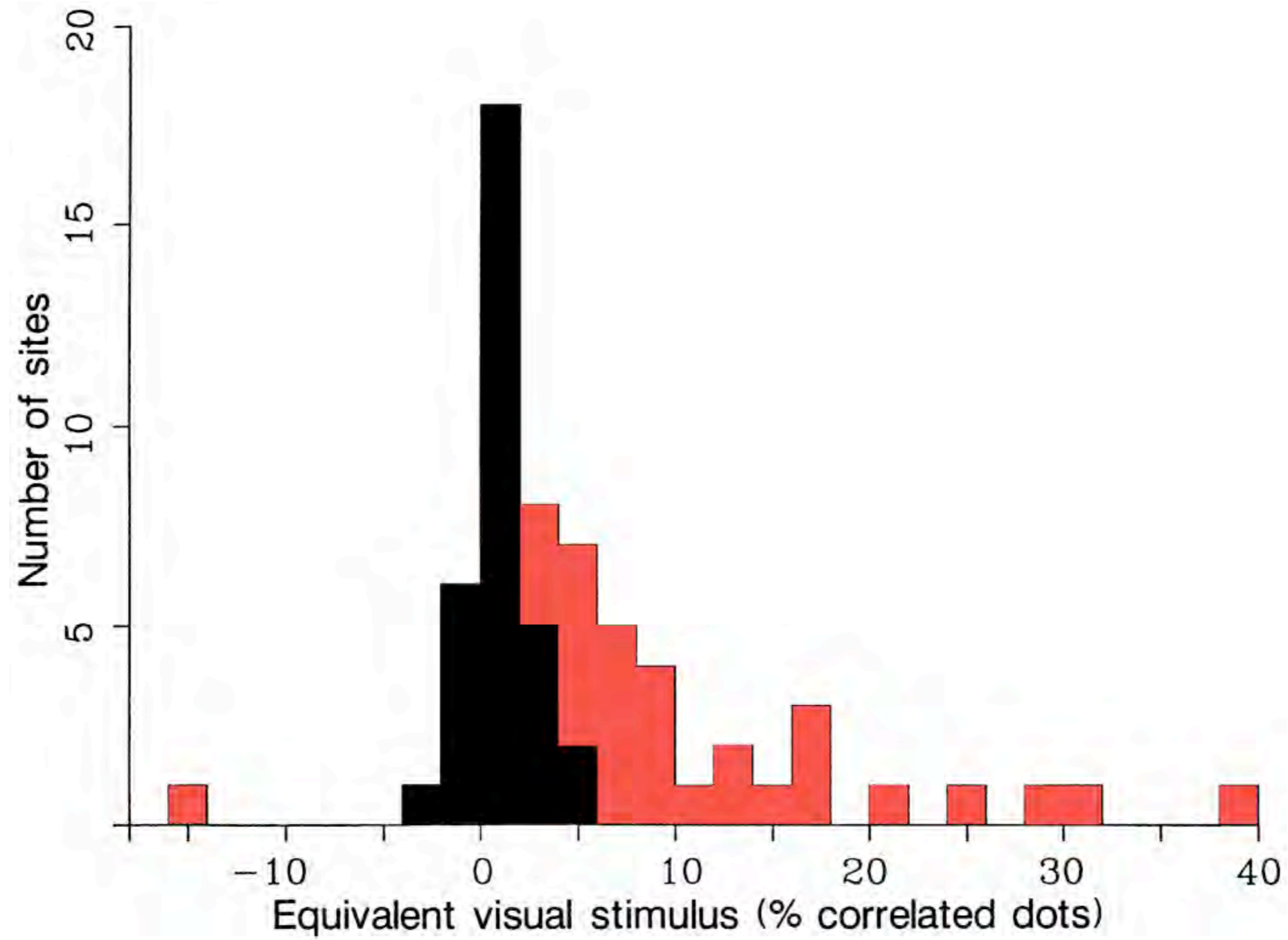

Effects of microstimulation of inferotemporal cortex on reports of seeing a face

Afraz et al. 2006



-80% -50% 0% 20% 50%

face
responses

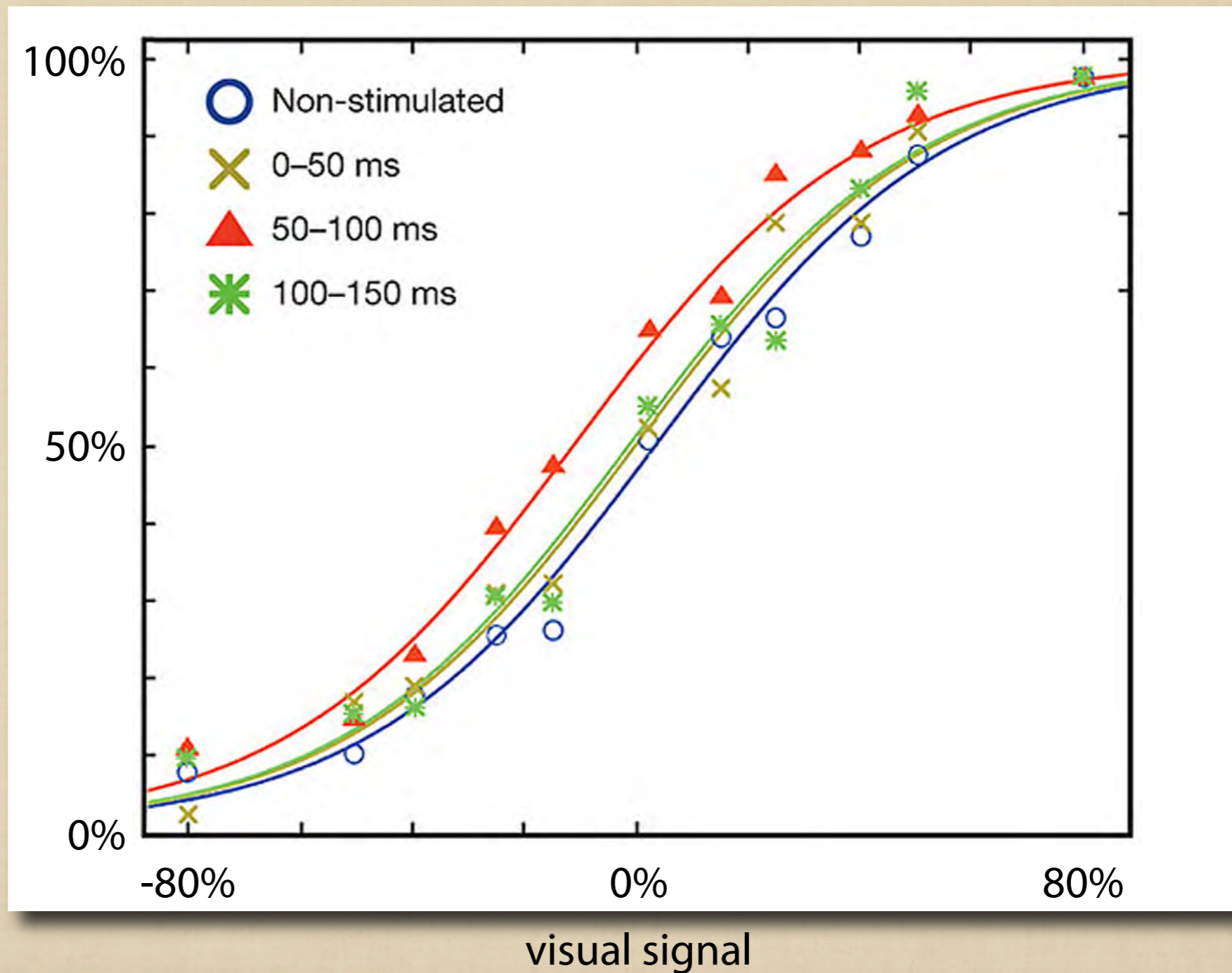

Periphery:

- correlation with neuronal sampling
- correlation with neuronal sensitivity

Central:

- selective effects of ablation
- selective effects of microstimulation
- correlation with neuronal performance

Retinal Ganglion Cell Responses to Weak Flashes

Barlow et al. 1971

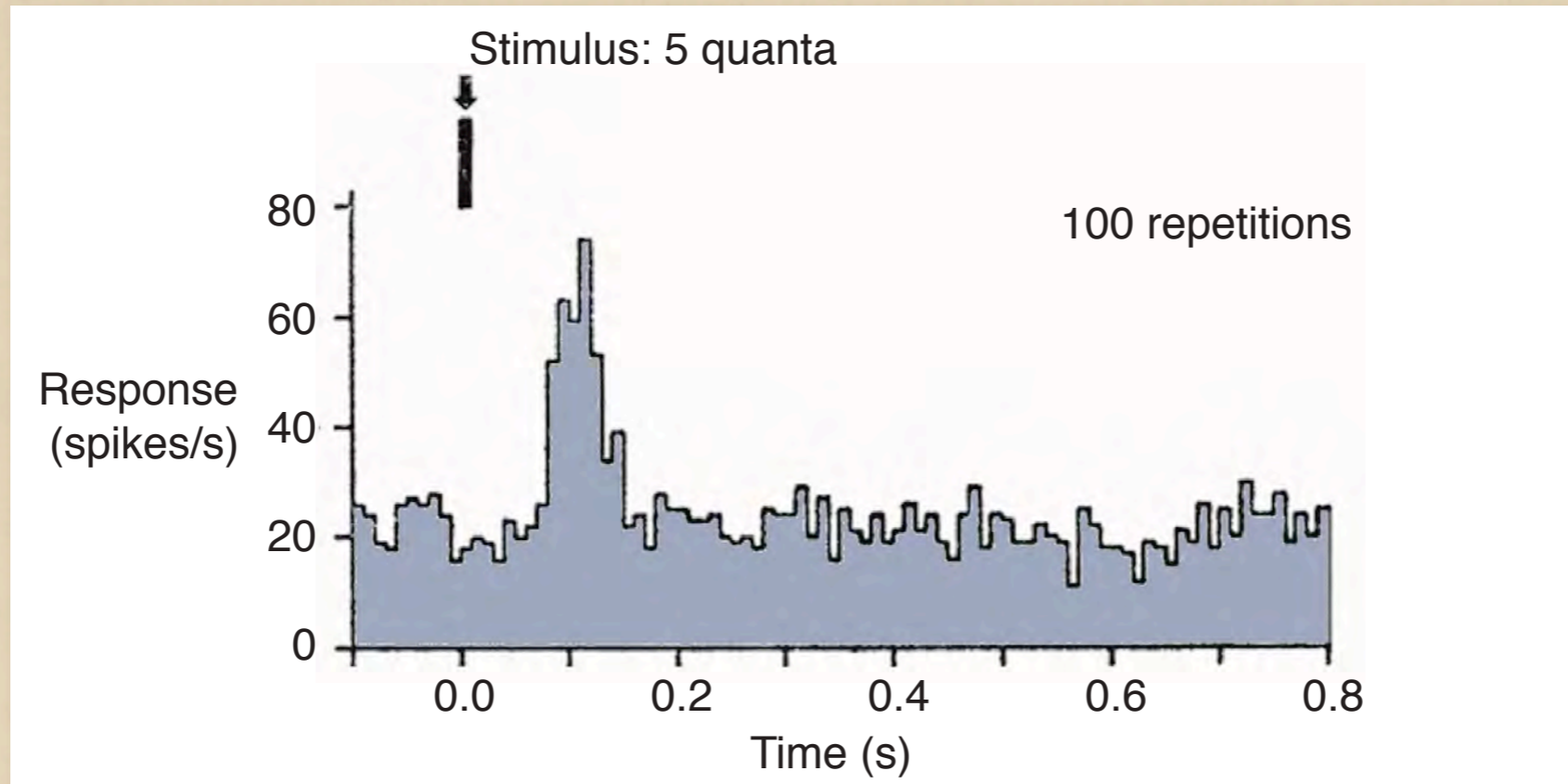

Retinal Ganglion Cell Responses to Weak Flashes

Barlow et al. 1971

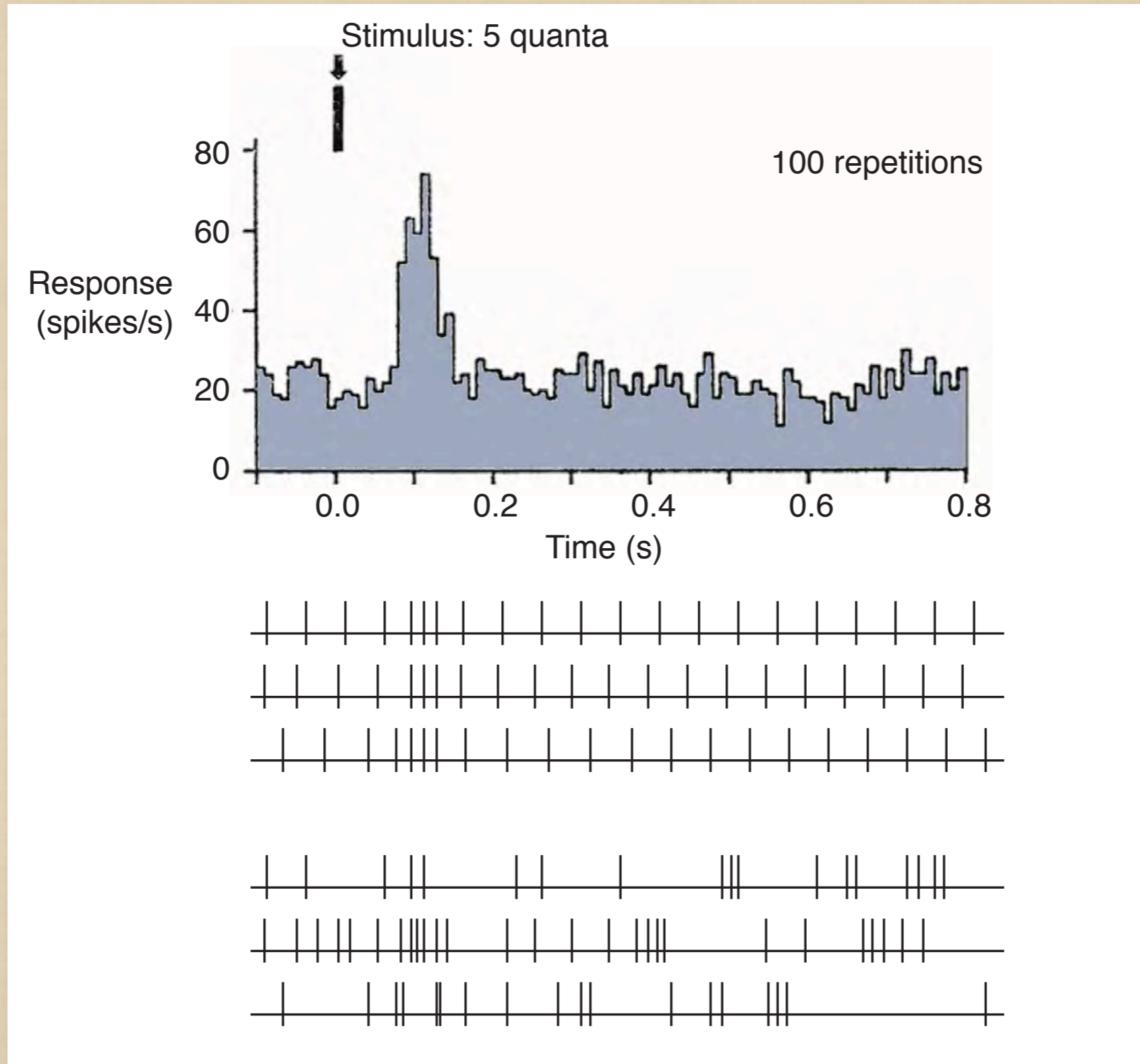

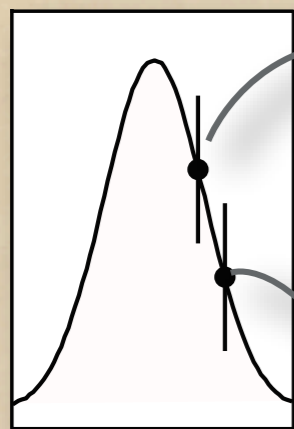

Orientation

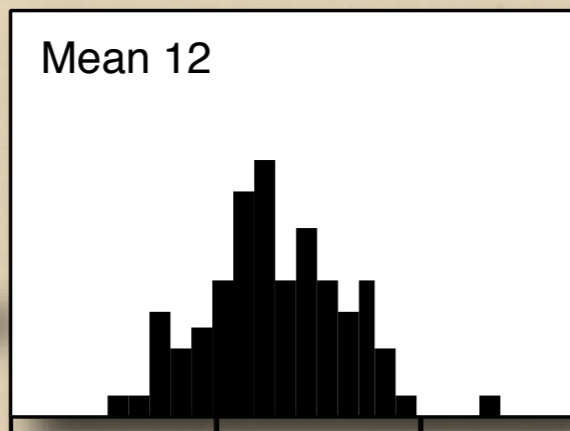

Mean 12

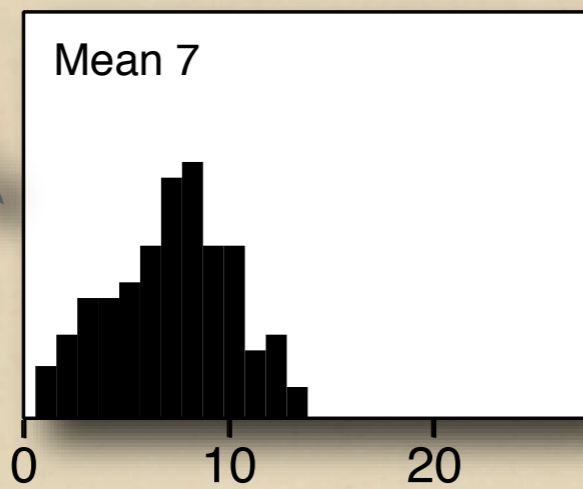

Spikes Per Stimulus

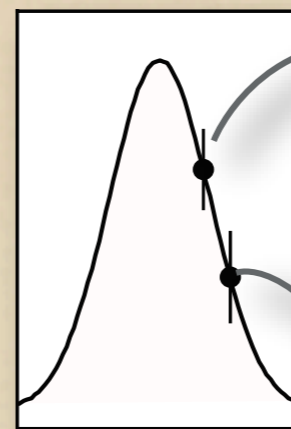

Orientation

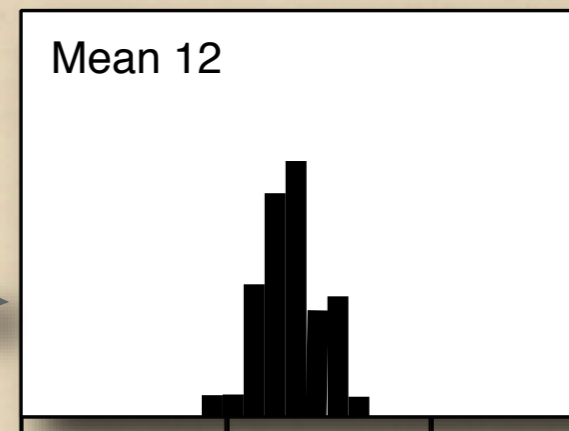

Mean 12

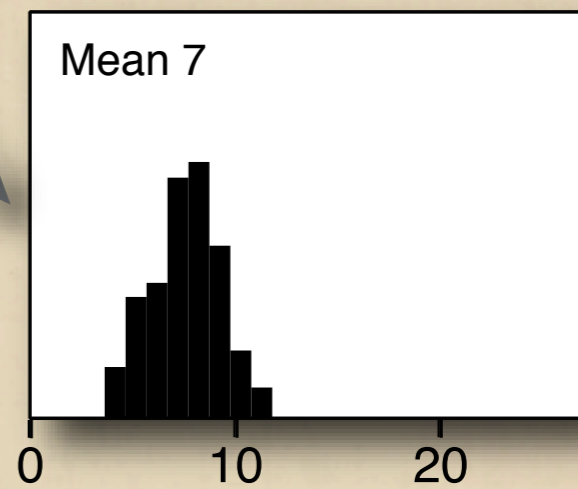

Spikes Per Stimulus

Variance of cat V1 neuron response

Dean 1981

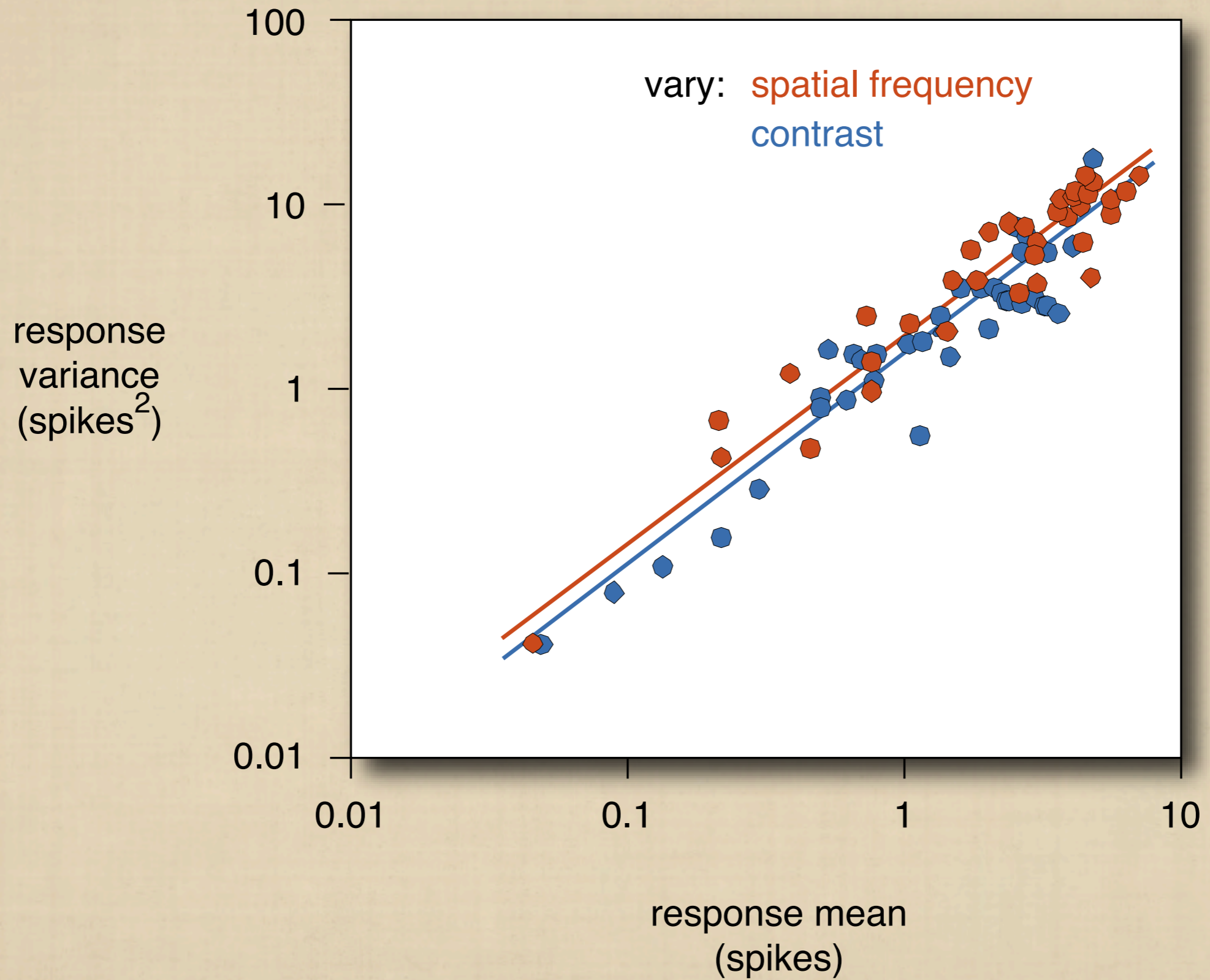

Relationship between response variance and mean

Britten et al. 1993

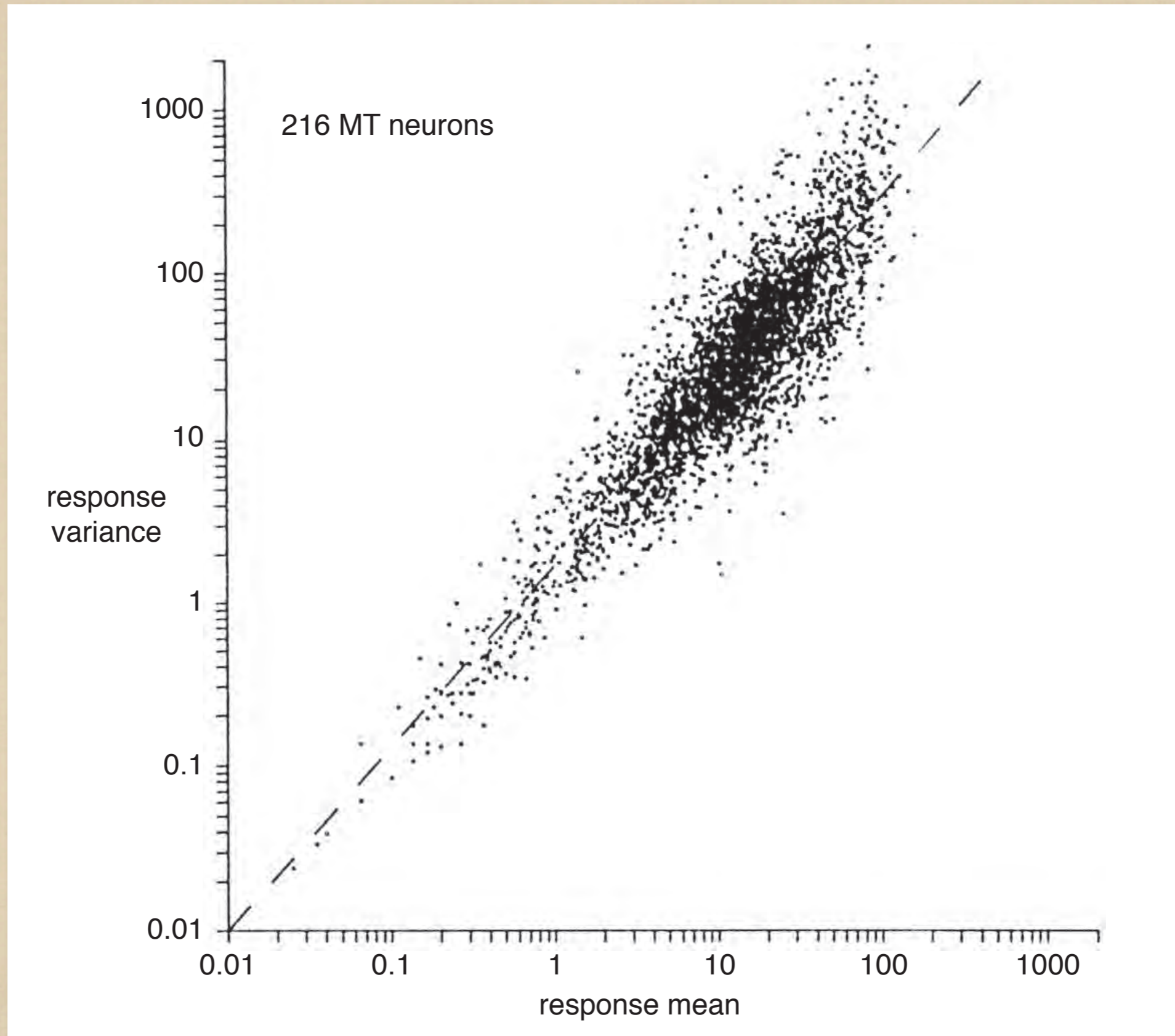

Poisson distributions

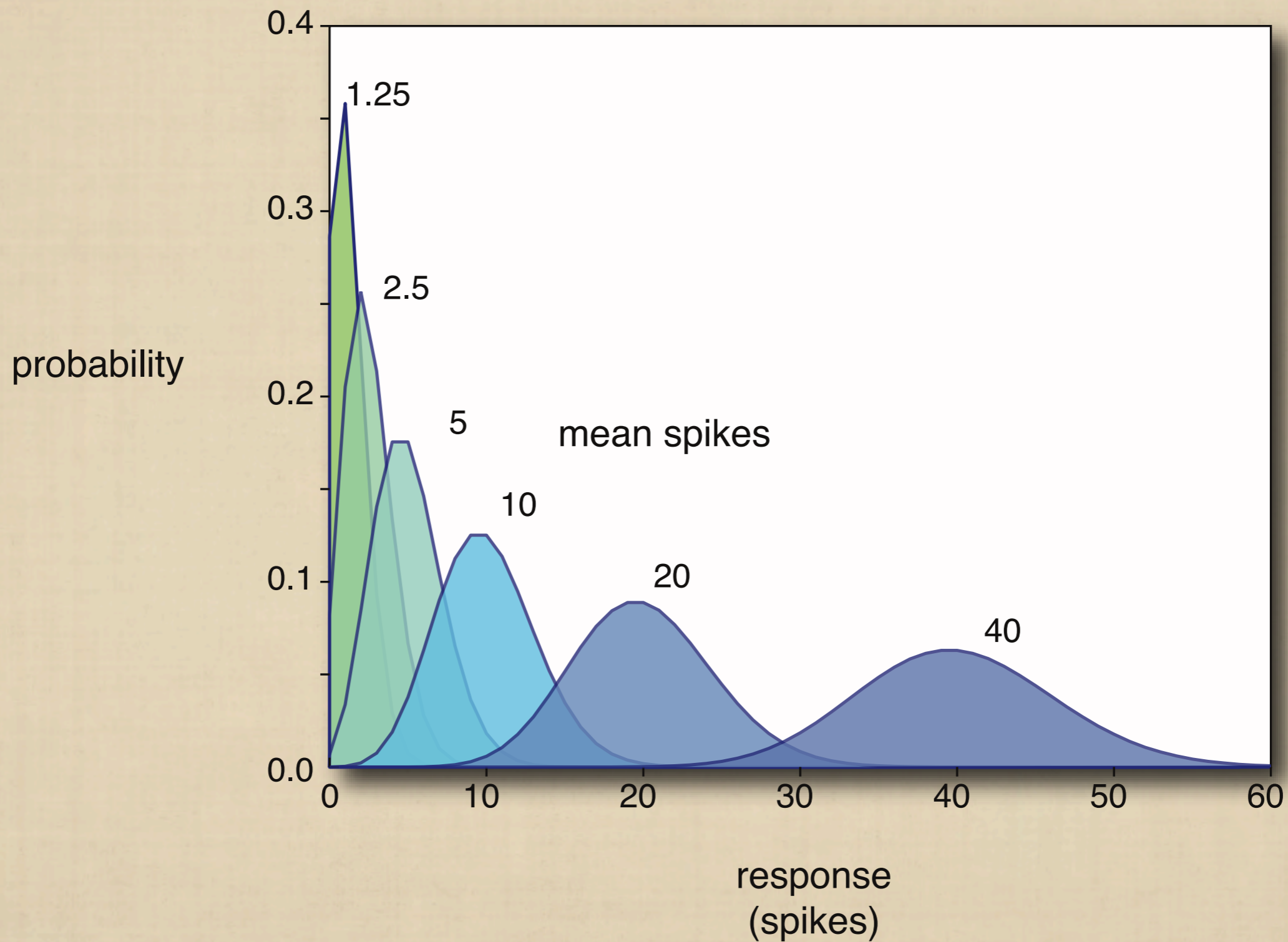

Retinal Ganglion Cell Responses to Weak Flashes

Barlow et al. 1971

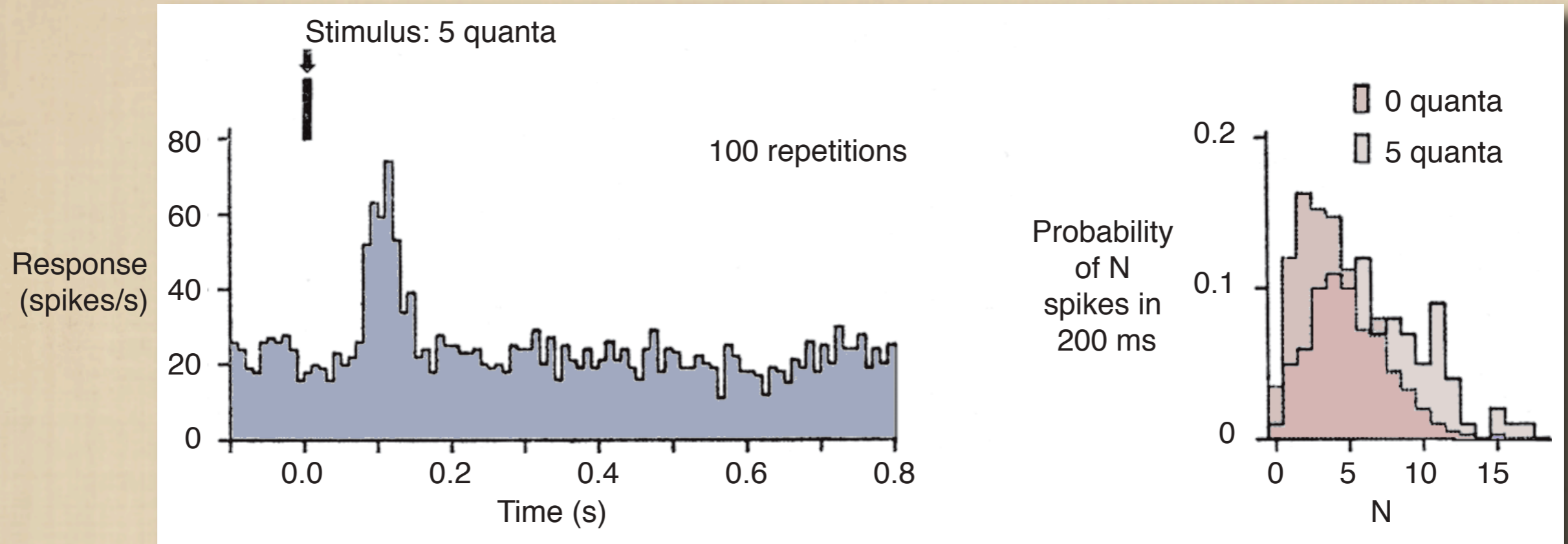

Receiver operating characteristic (ROC) analysis

Barlow et al. 1971

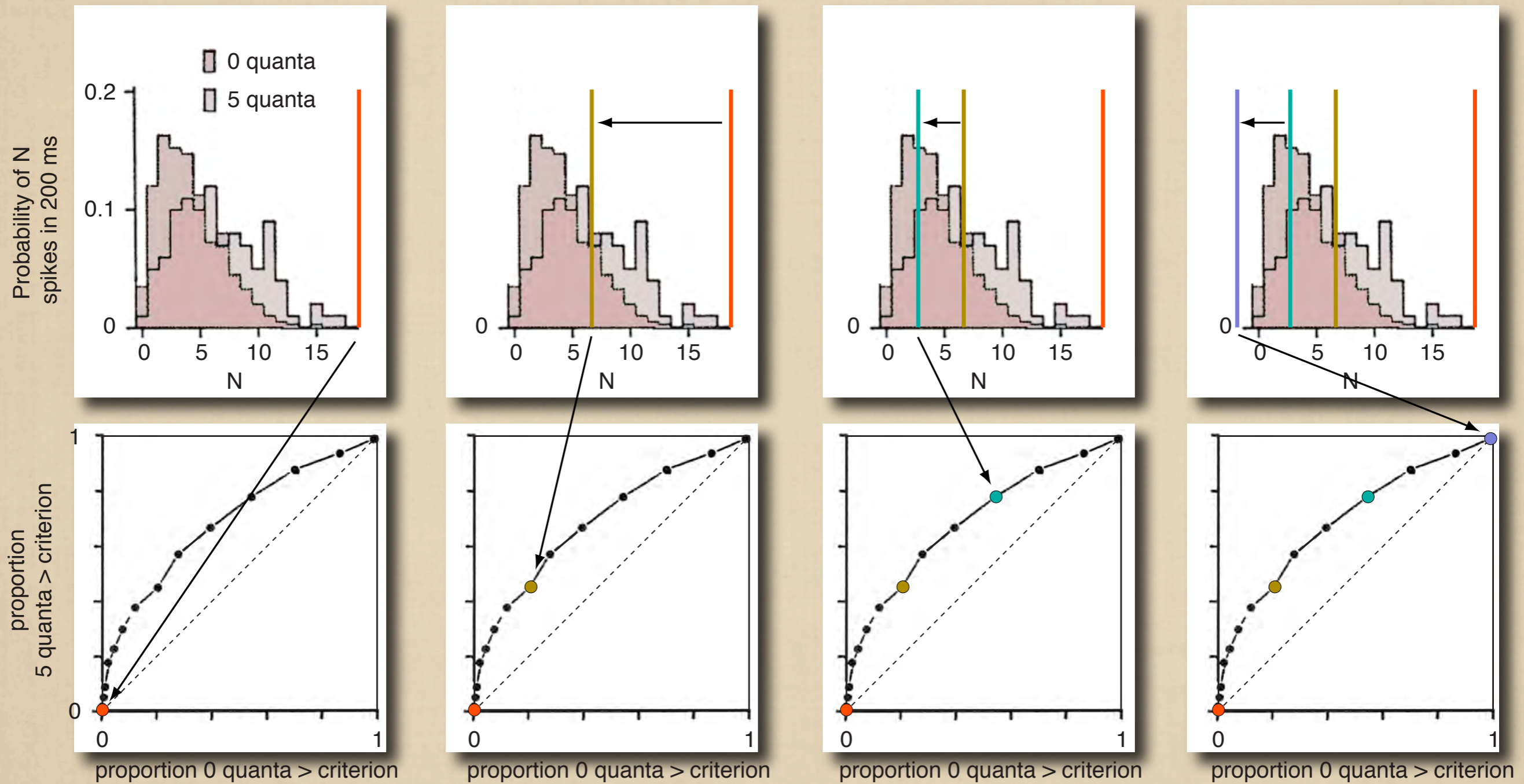

Retinal Ganglion Cell Responses to Weak Flashes

Barlow et al. 1971

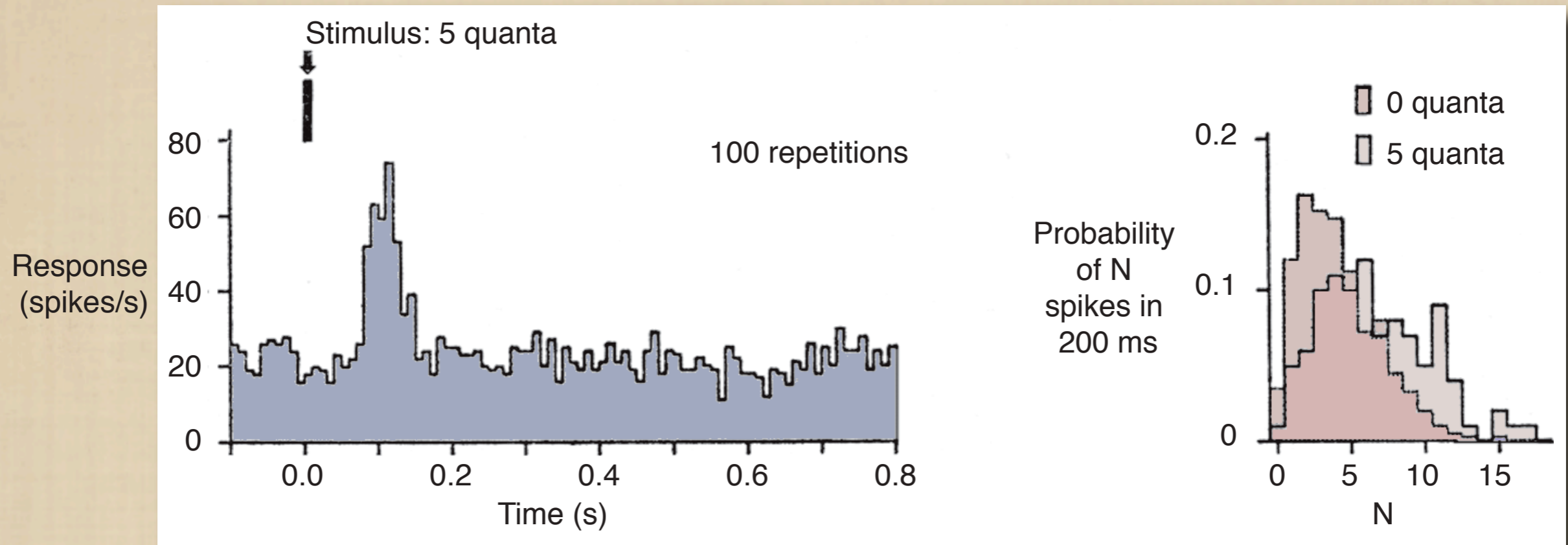

Receiver Operating Characteristic (ROC) analysis

proportion
5 quanta > criterion

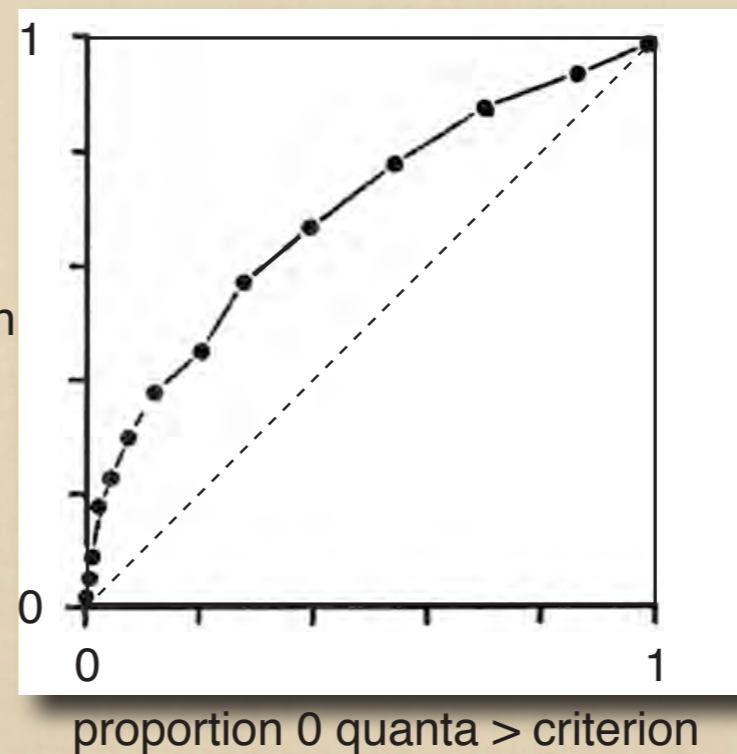

Receiver Operating Characteristic (ROC) Analysis

Britten et al. 1993

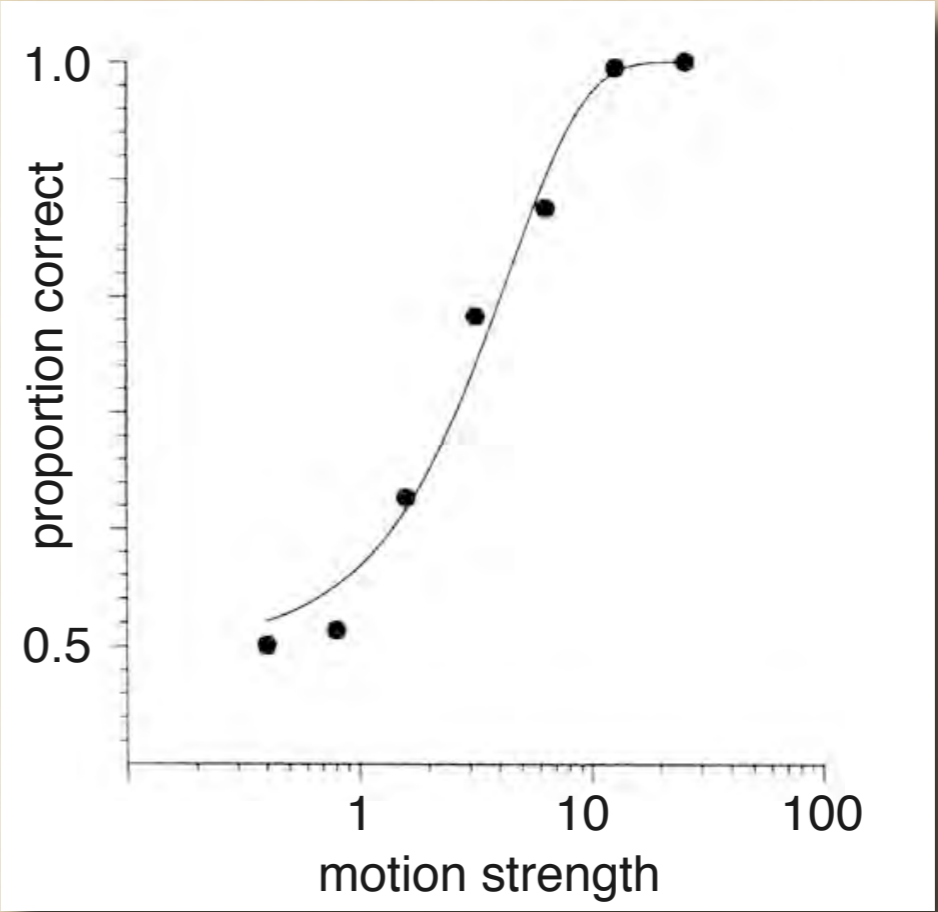
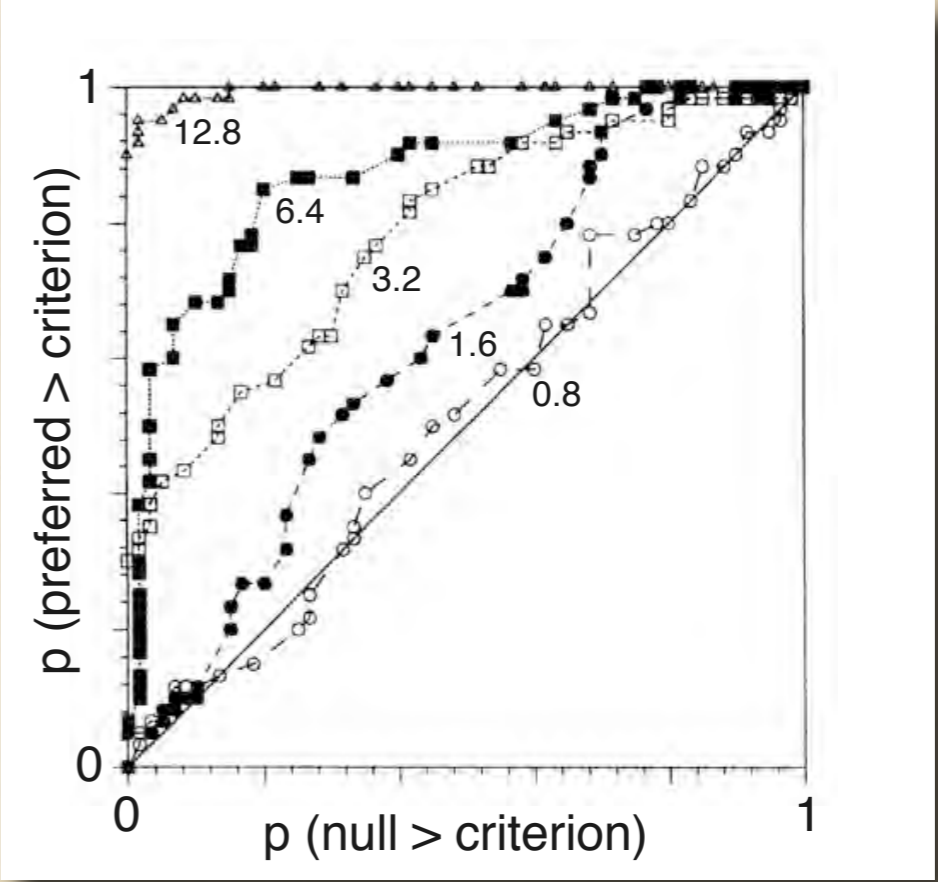
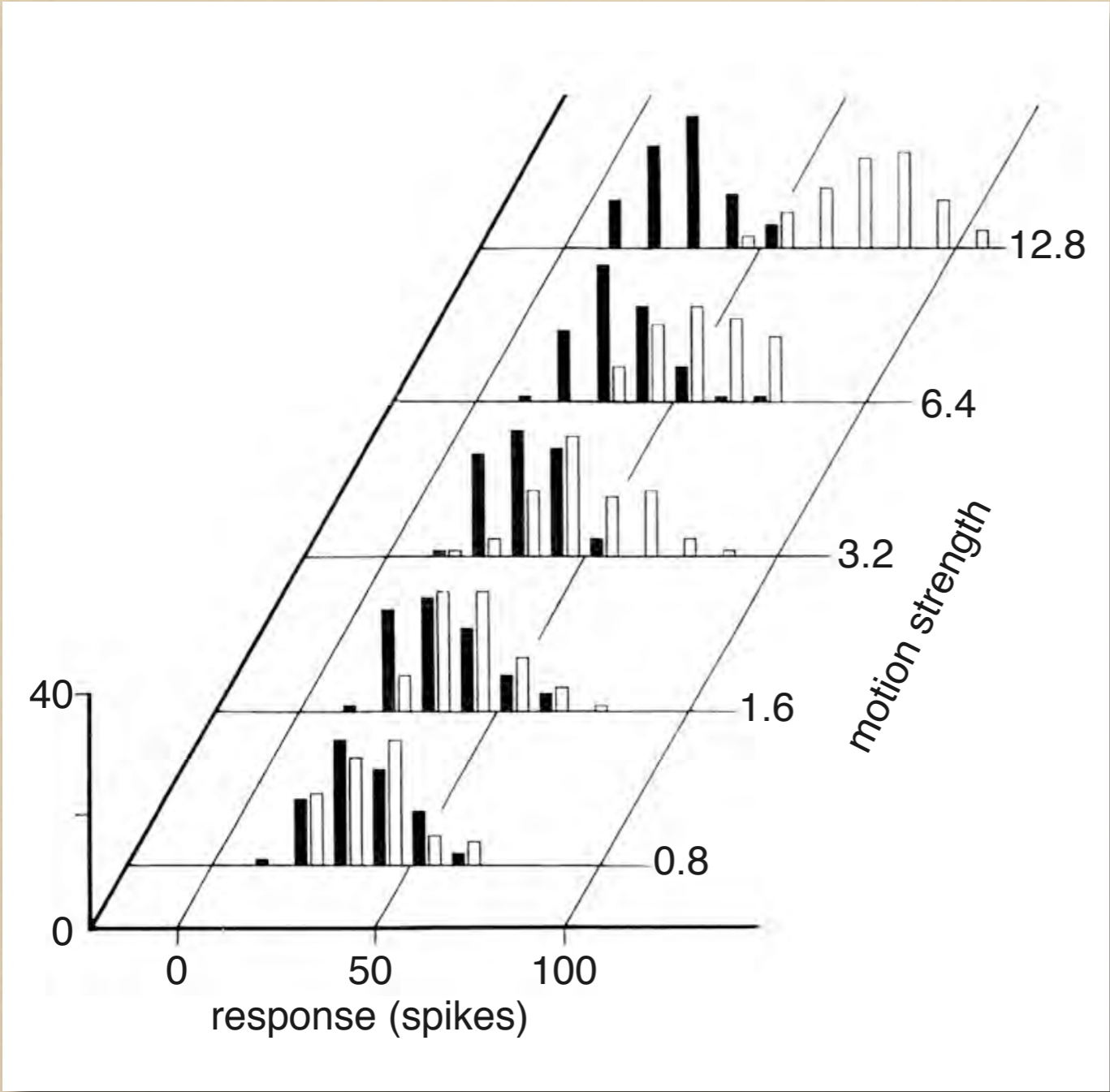

Corresponding behavioral and single unit performance (MT)

Britten et al. (1992)

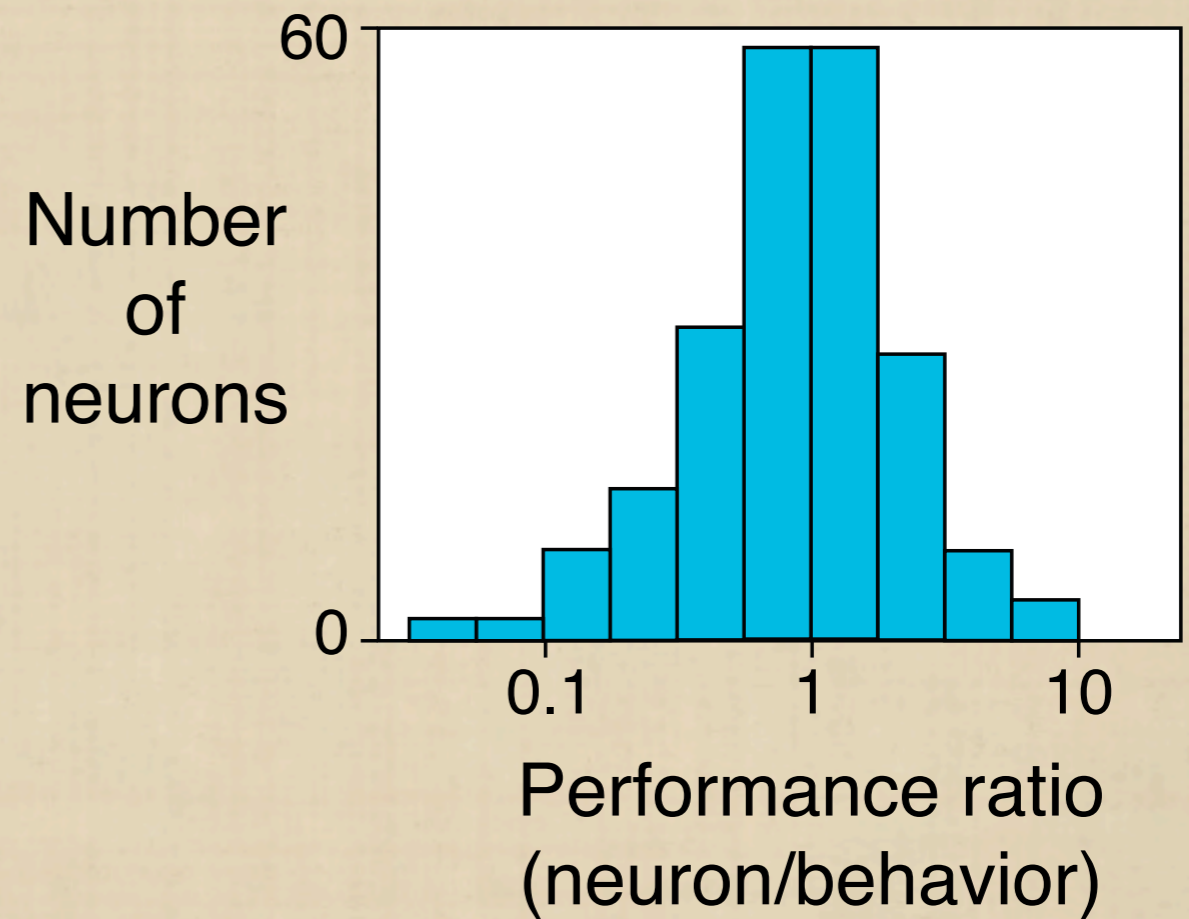
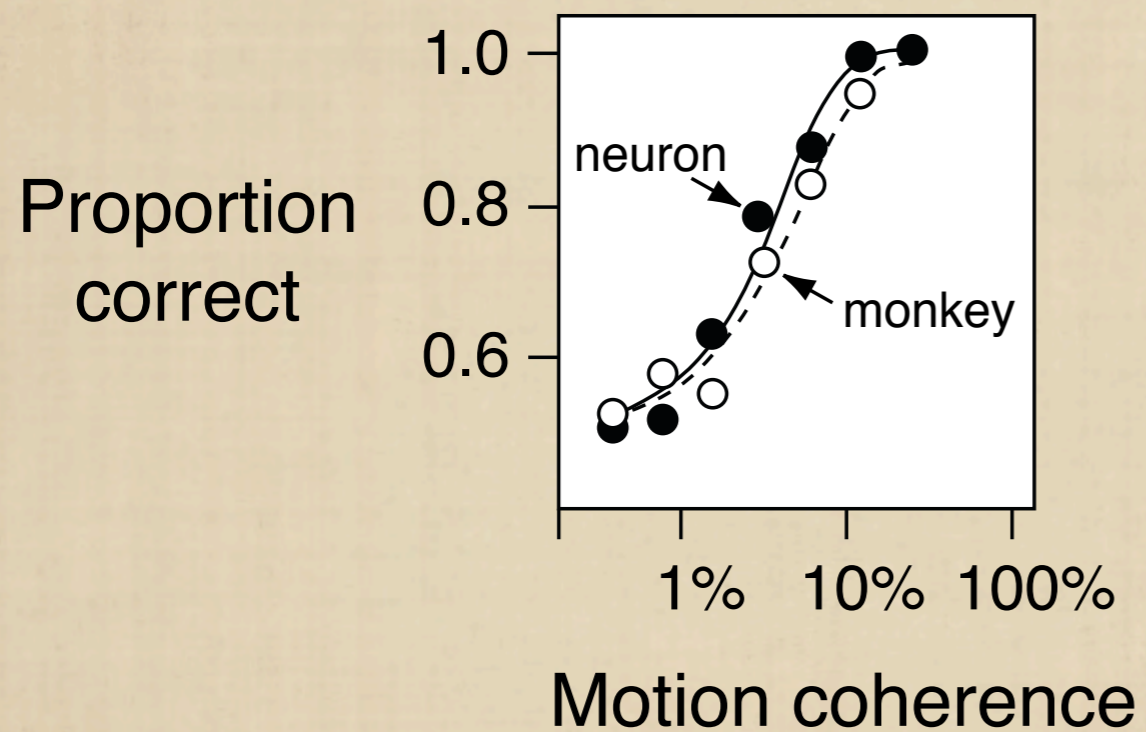

Corresponding behavioral and single unit performance (MT)

Britten et al. (1992)

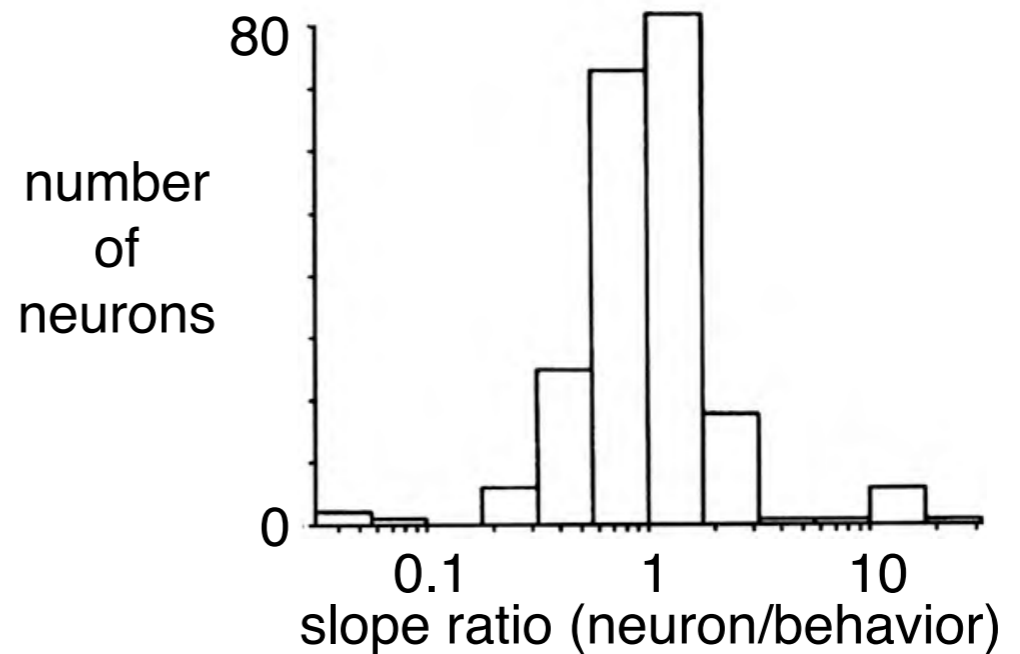
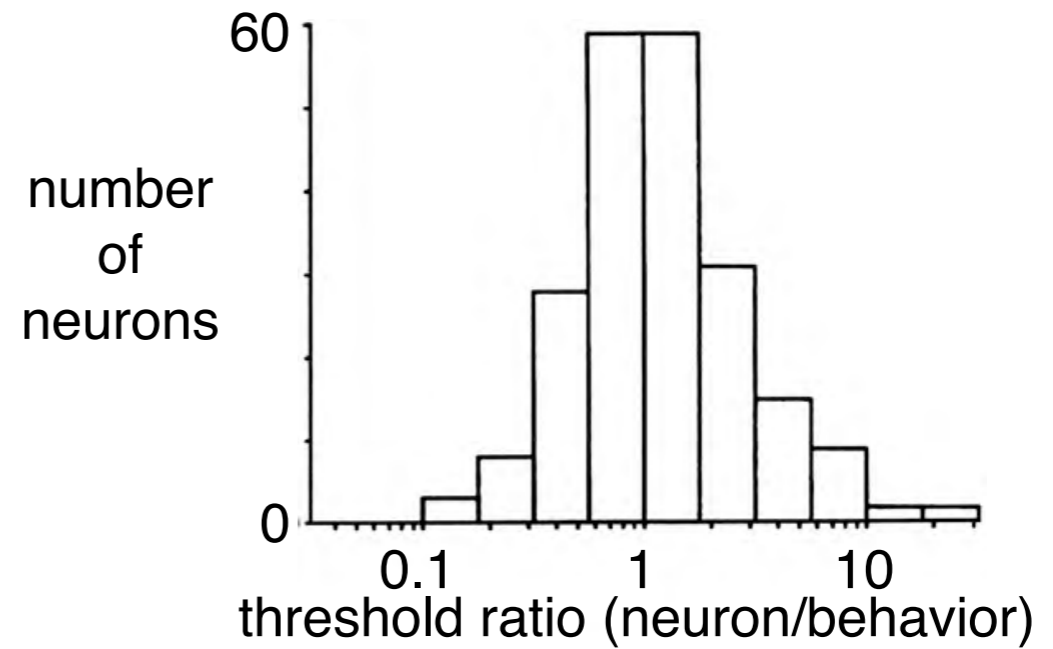
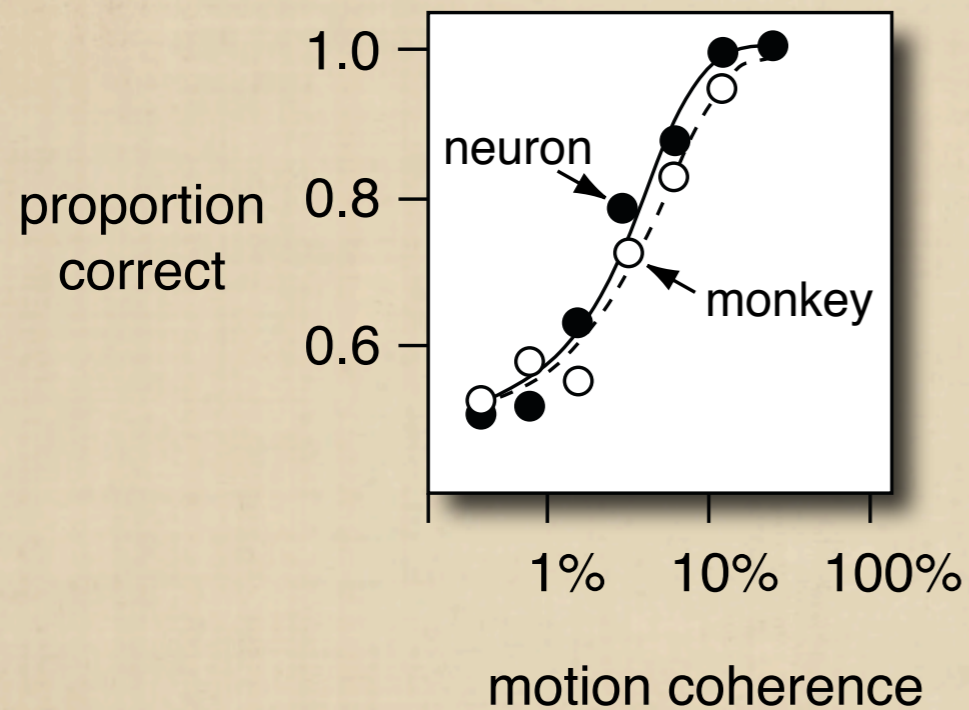

Temperature change threshold for monkey thermoreceptors

Johnston et al., 1973

effect of number of neurons

effect of correlation

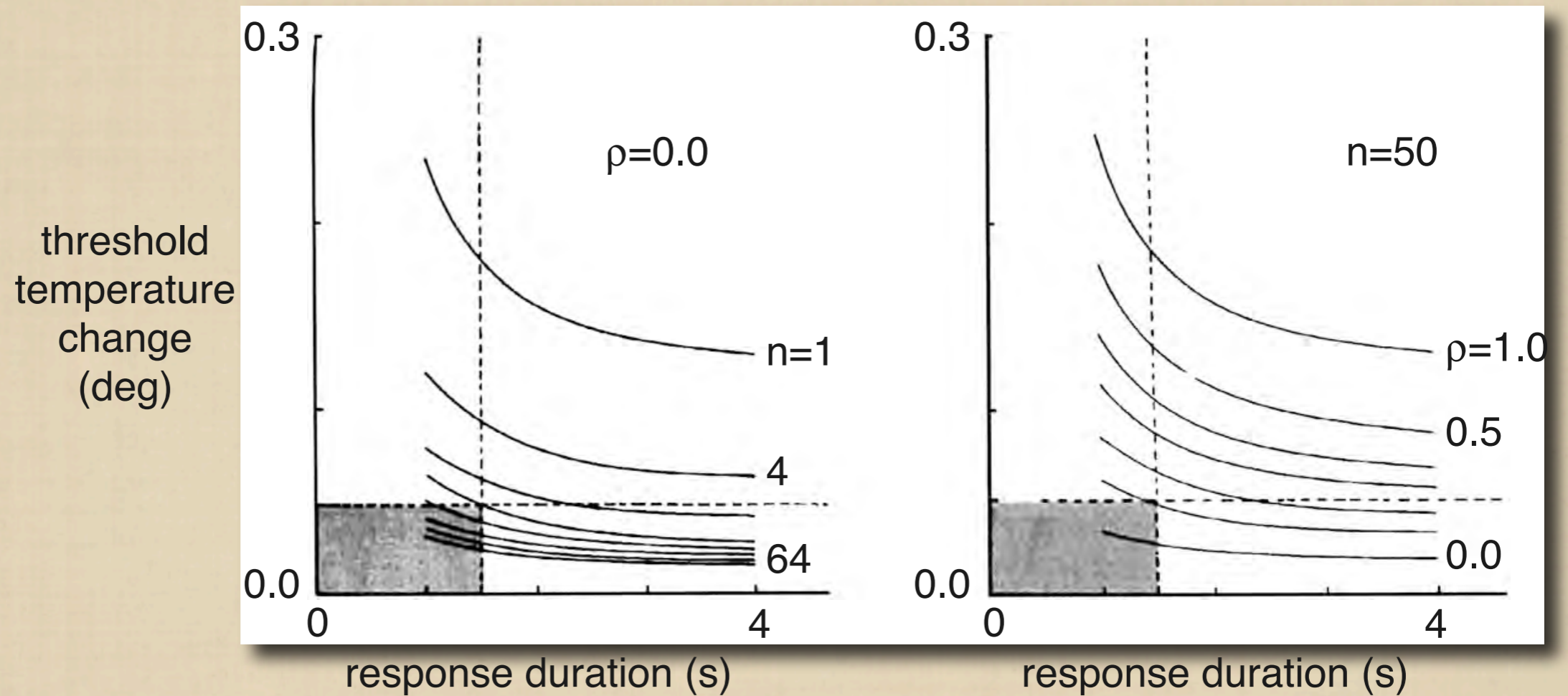

Periphery:

- correlation with neuronal sampling
- correlation with neuronal sensitivity

Central:

- selective effects of ablation
- selective effects of microstimulation
- correlation with neuronal performance
- trial-by-trial correlation with choice

Correlation between MT neuron activity and behavioral choice

Britten et al. 1996

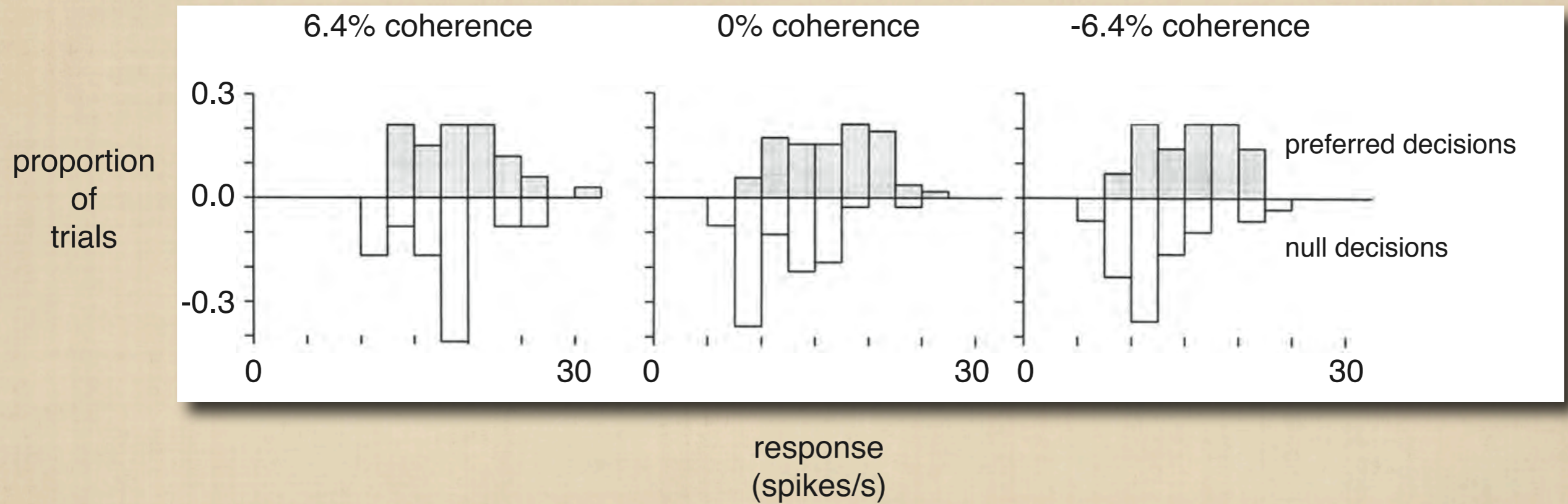

Choice probability with stimulus off the receptive field

Britten et al. 1996

proportion
of
neurons

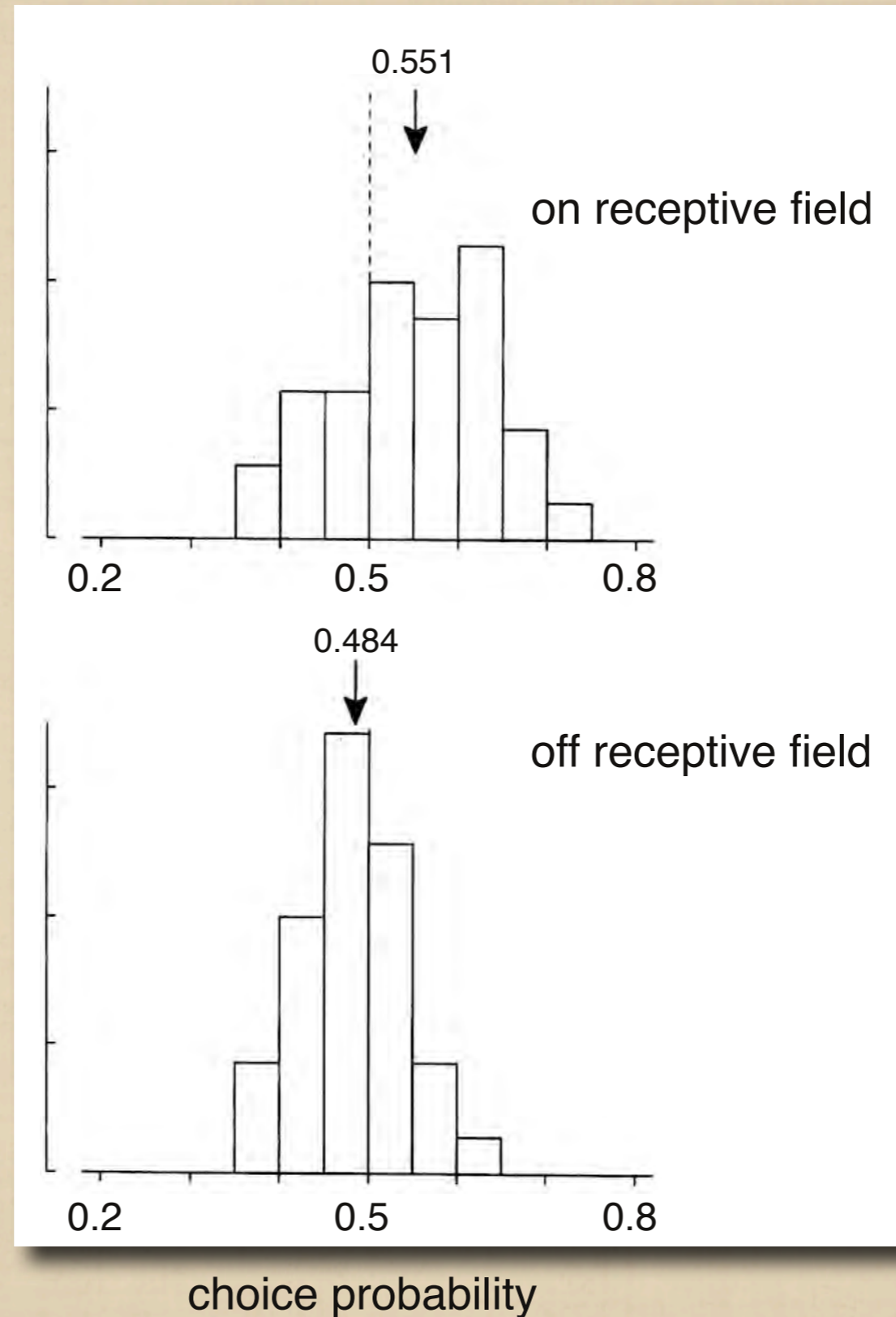

proportion
of
neurons

choice probability

Correlation between choice probability and neuronal performance

Britten et al. 1996

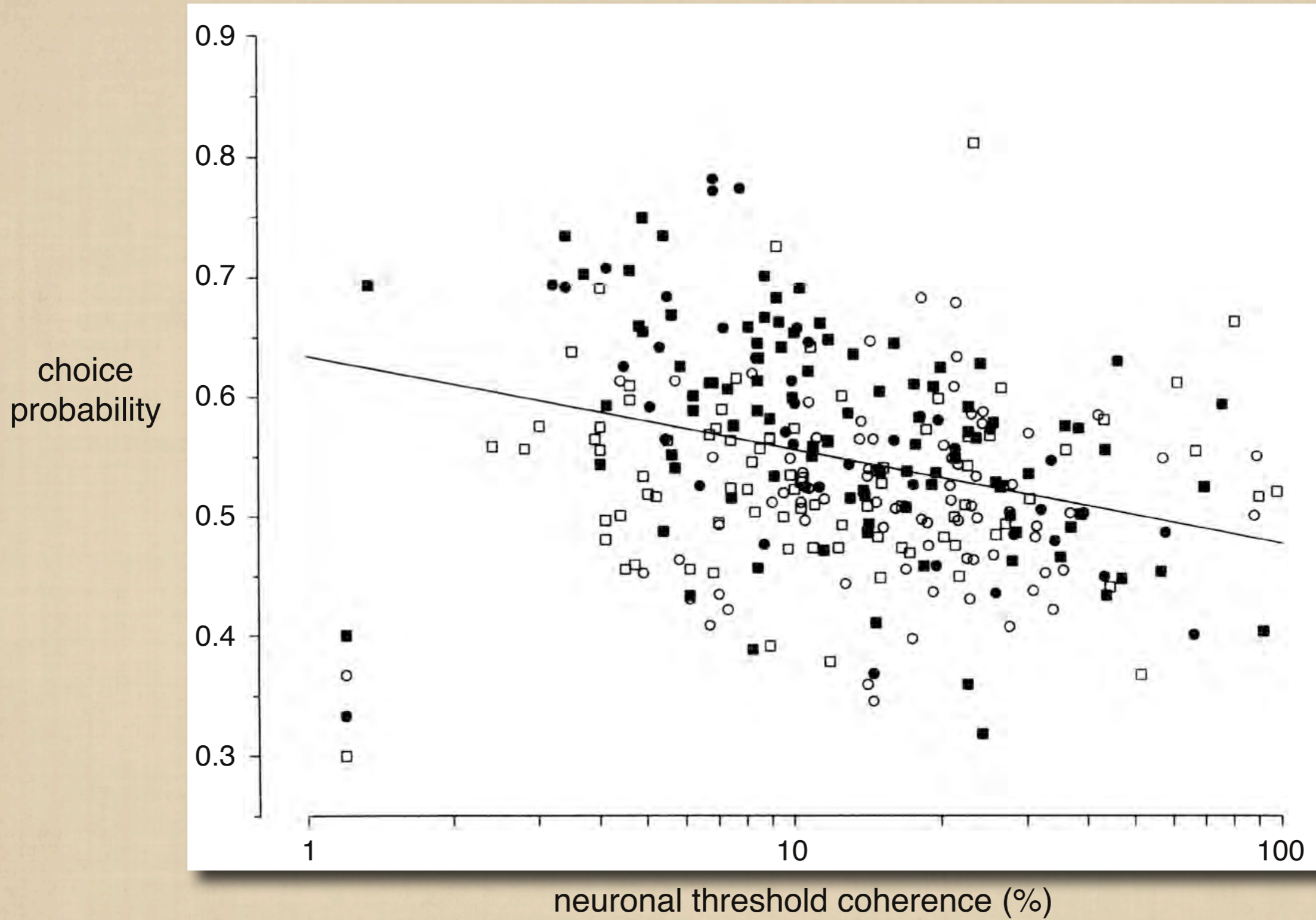

Periphery:

- correlation with neuronal sampling
- correlation with neuronal sensitivity

Central:

- selective effects of ablation
- selective effects of microstimulation
- correlation with neuronal performance
- trial-by-trial correlation with choice
- trial-by-trial correlation with reaction time

Motion detection task

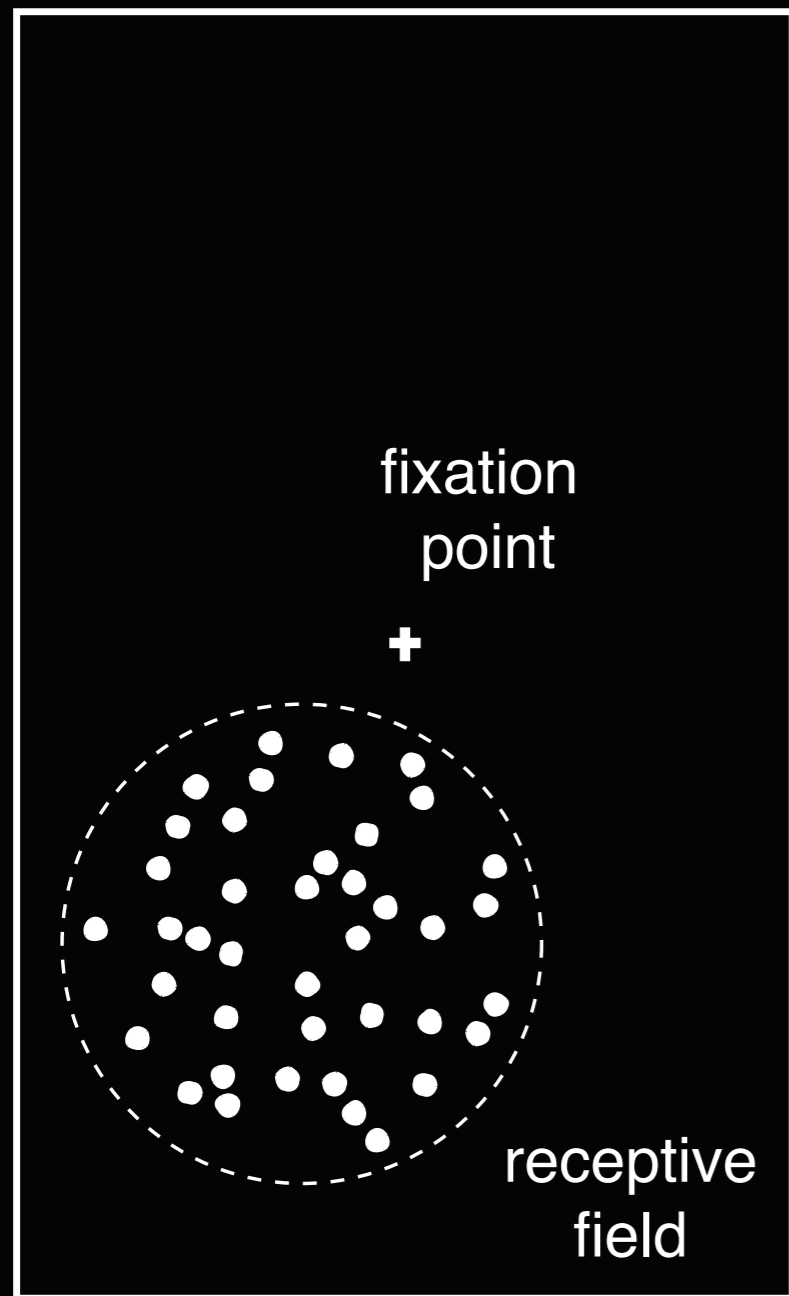

Cue

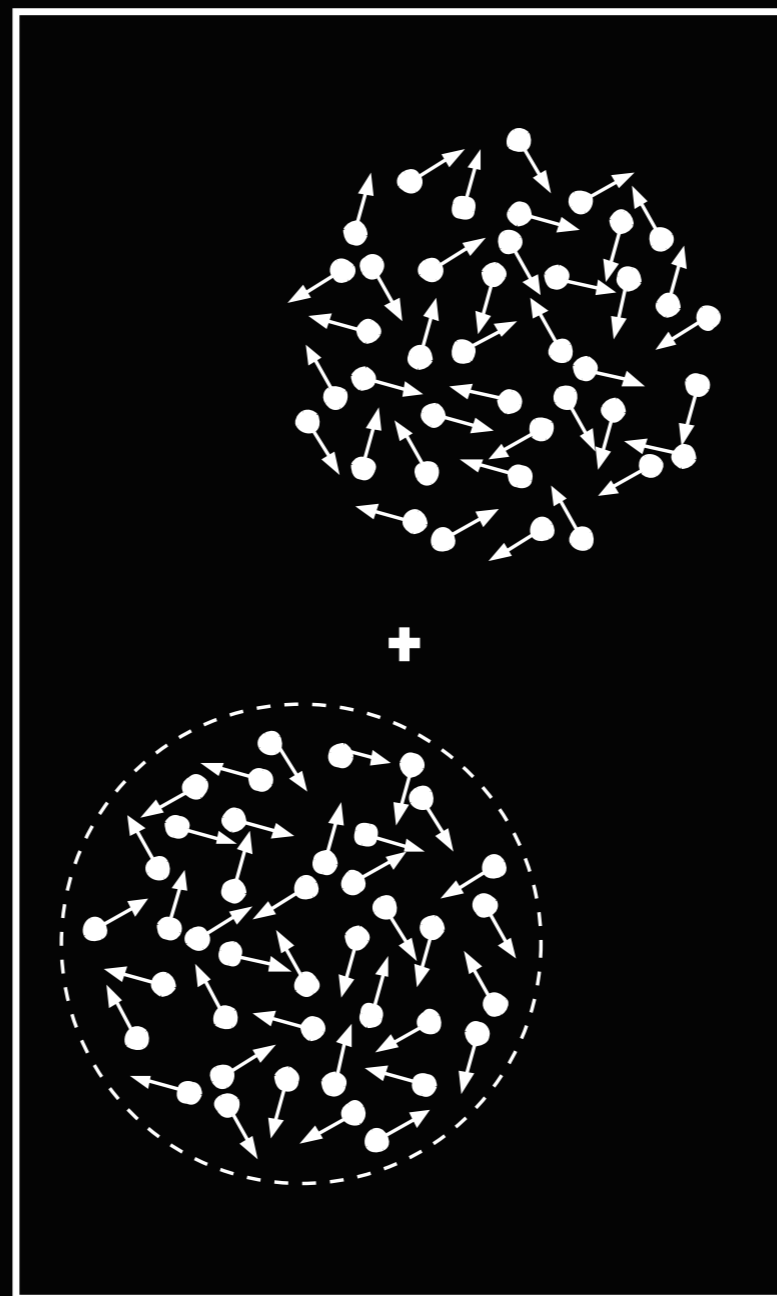

0.0 coherent
(500 - 8000 ms)

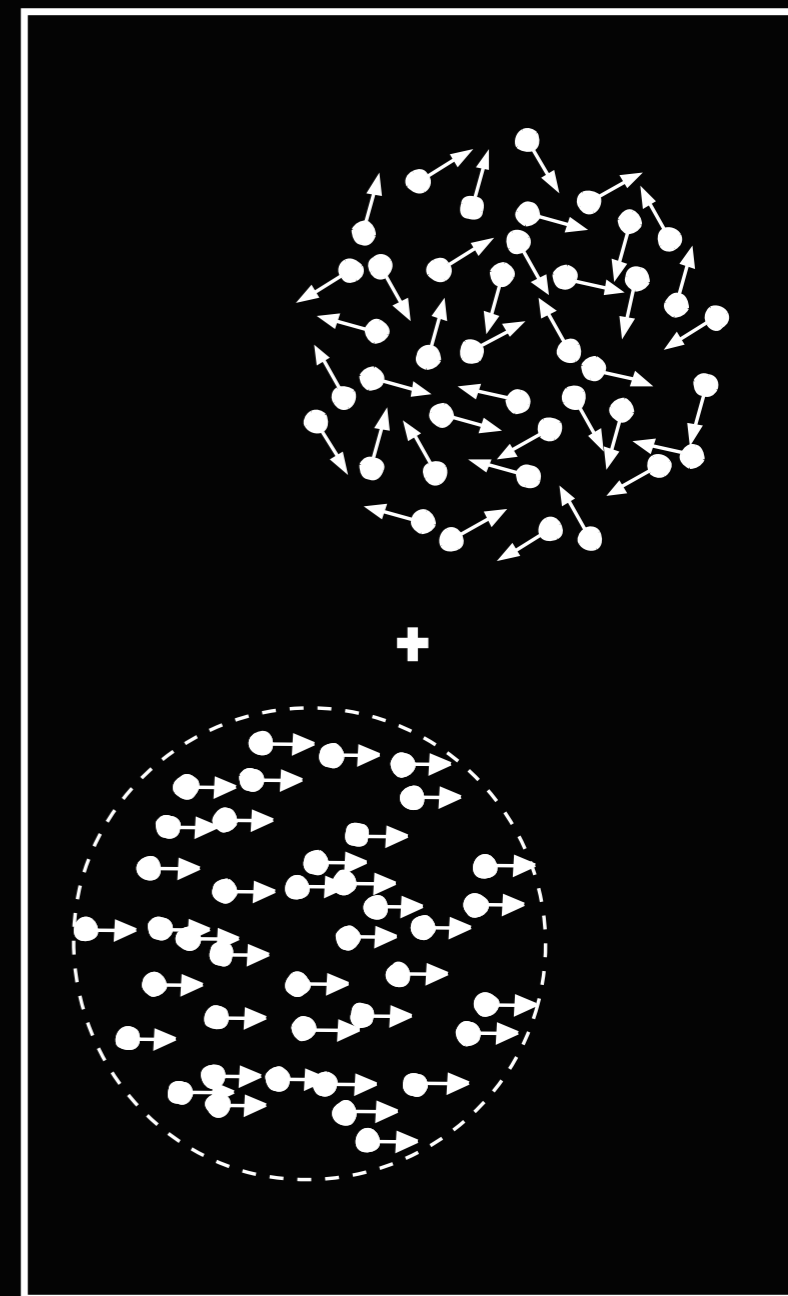

Coherent motion
(750 ms)

Time \longrightarrow

Responses of MT neuron to motion onset

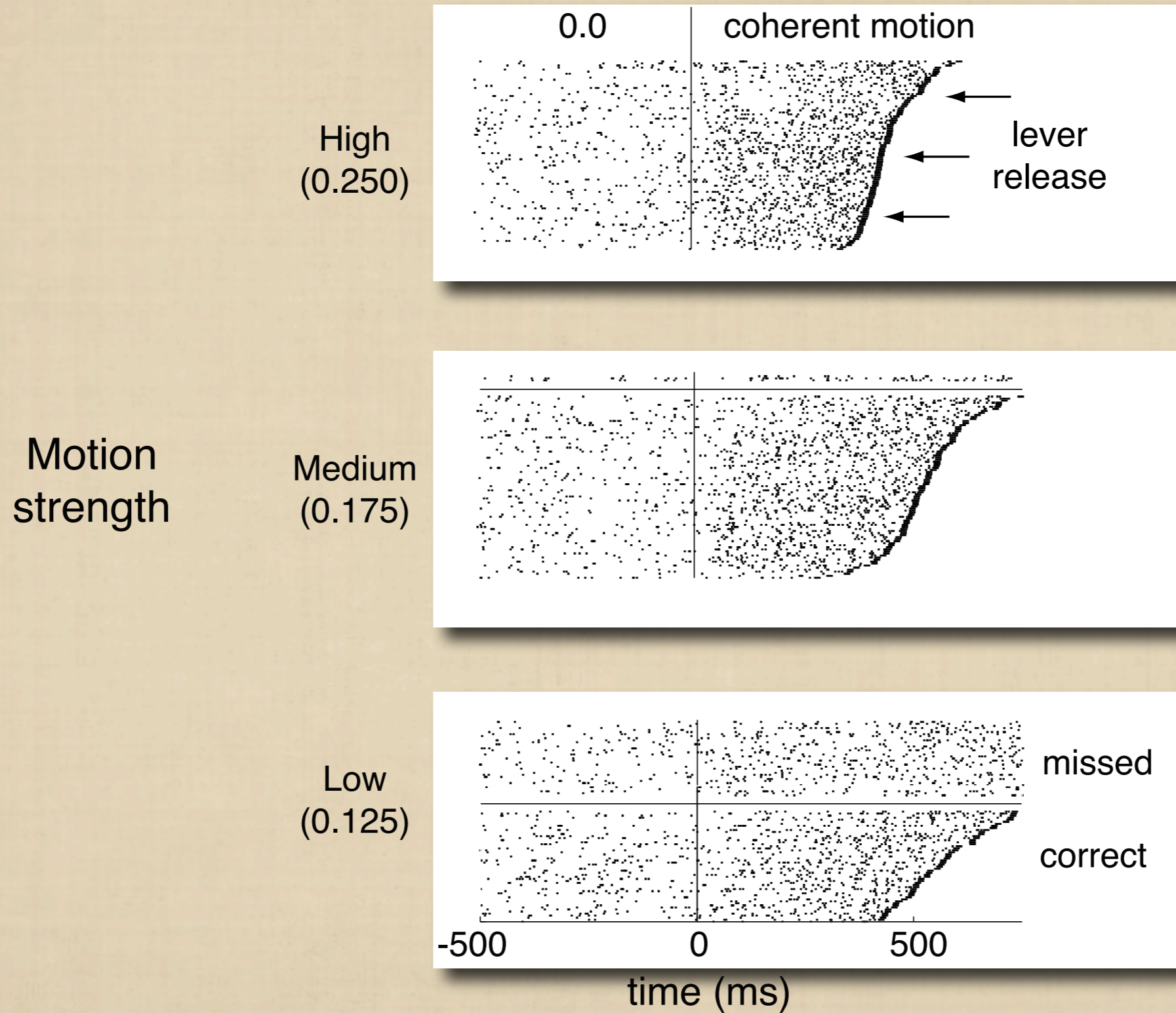

Responses of MT and VIP neurons correlate with reaction time

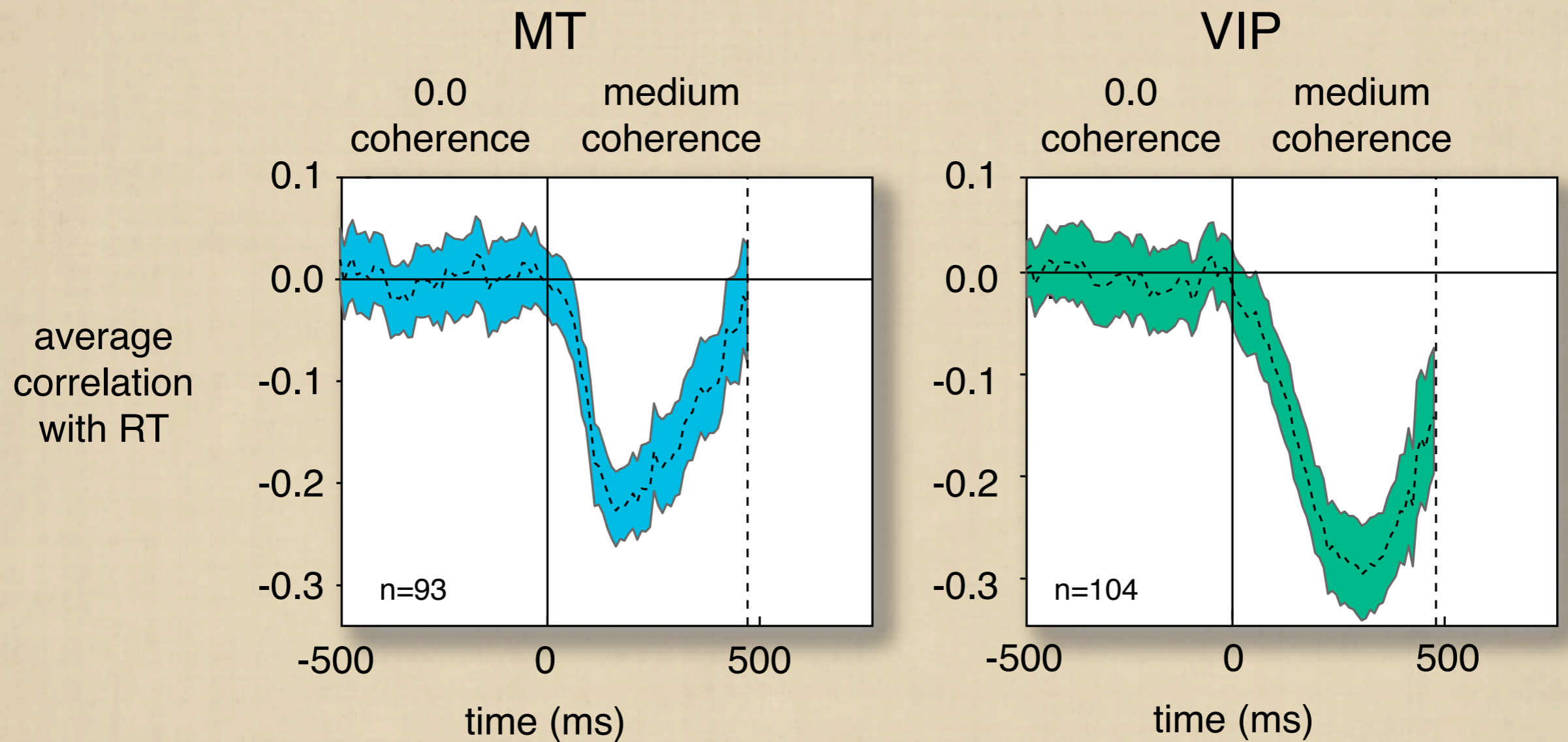

Correlation with reaction time in MT varies with direction of motion

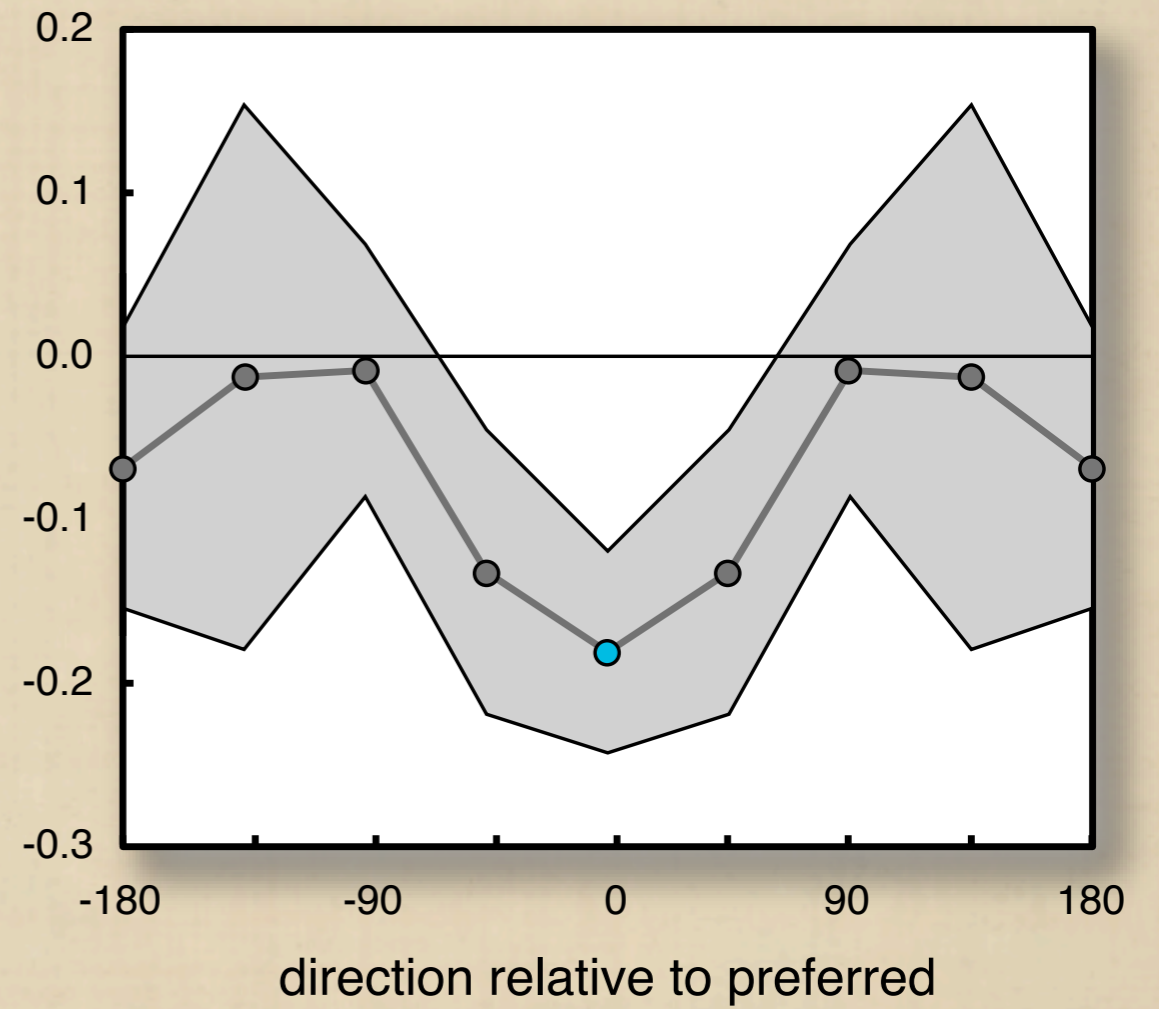
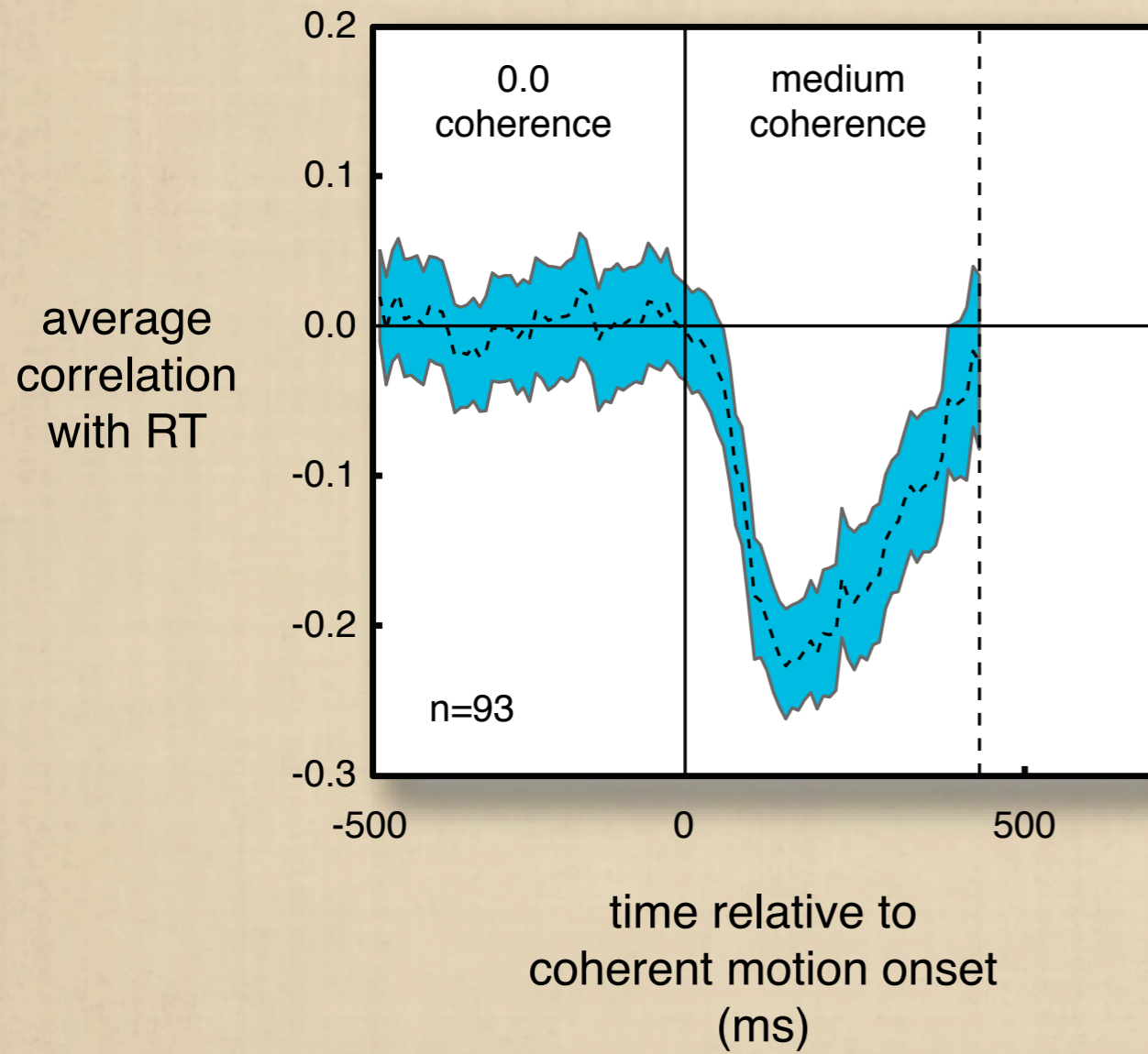

Periphery:

- correlation with neuronal sampling
- correlation with neuronal sensitivity

Central:

- selective effects of ablation
- selective effects of microstimulation
- correlation with neuronal performance
- trial-by-trial correlation with choice
- trial-by-trial correlation with reaction time
- correlation with perception during rivalry

Binocular rivalry

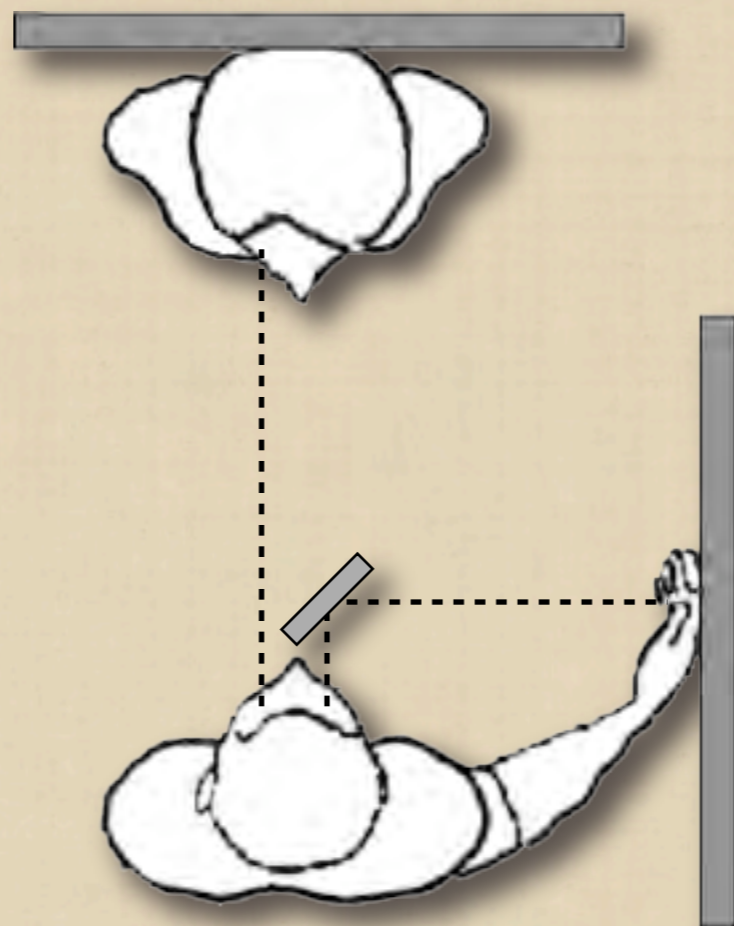

Binocular rivalry in early monkey visual cortex

Logothetis et al. 1996, 1997

left eye

right eye

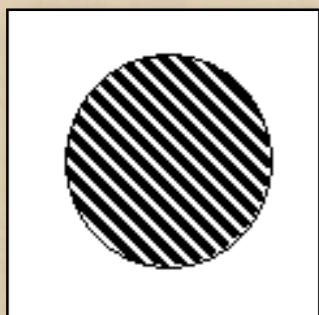

animal reports null

animal reports preferred

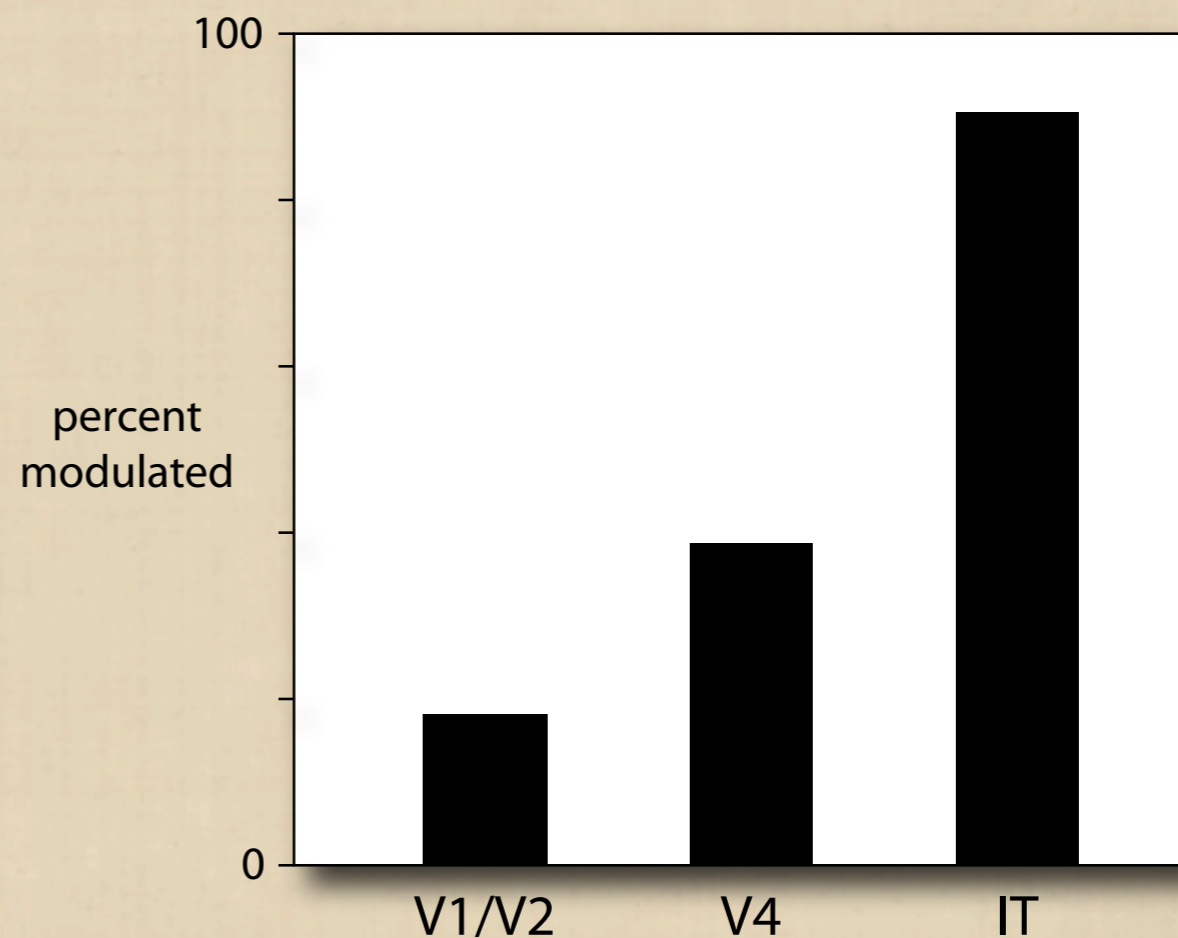
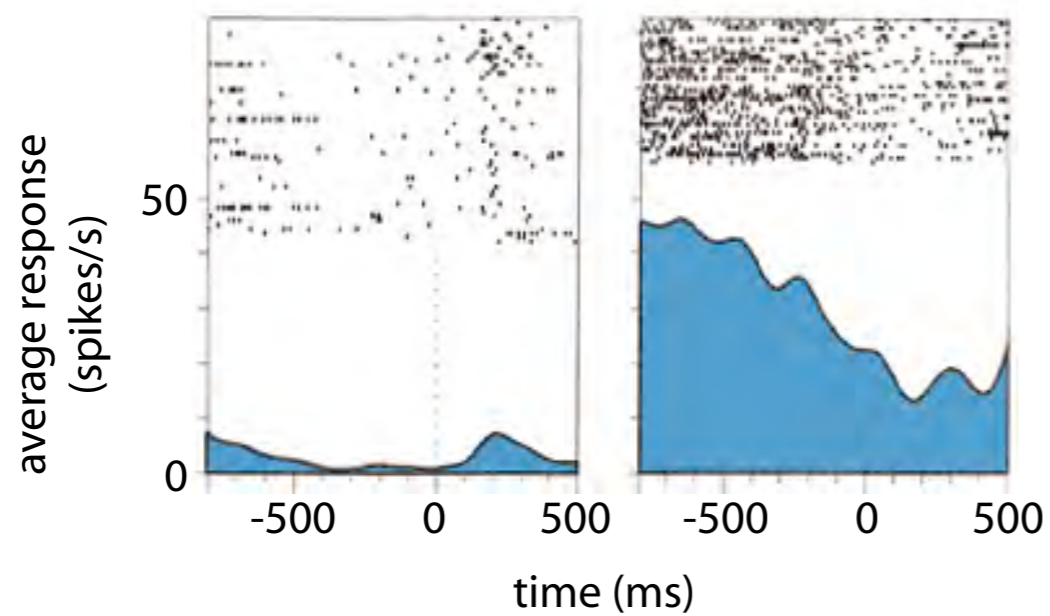

fMRI of Rivalry in Human V1

Polonsky, Blake, Braun, Heeger 2000

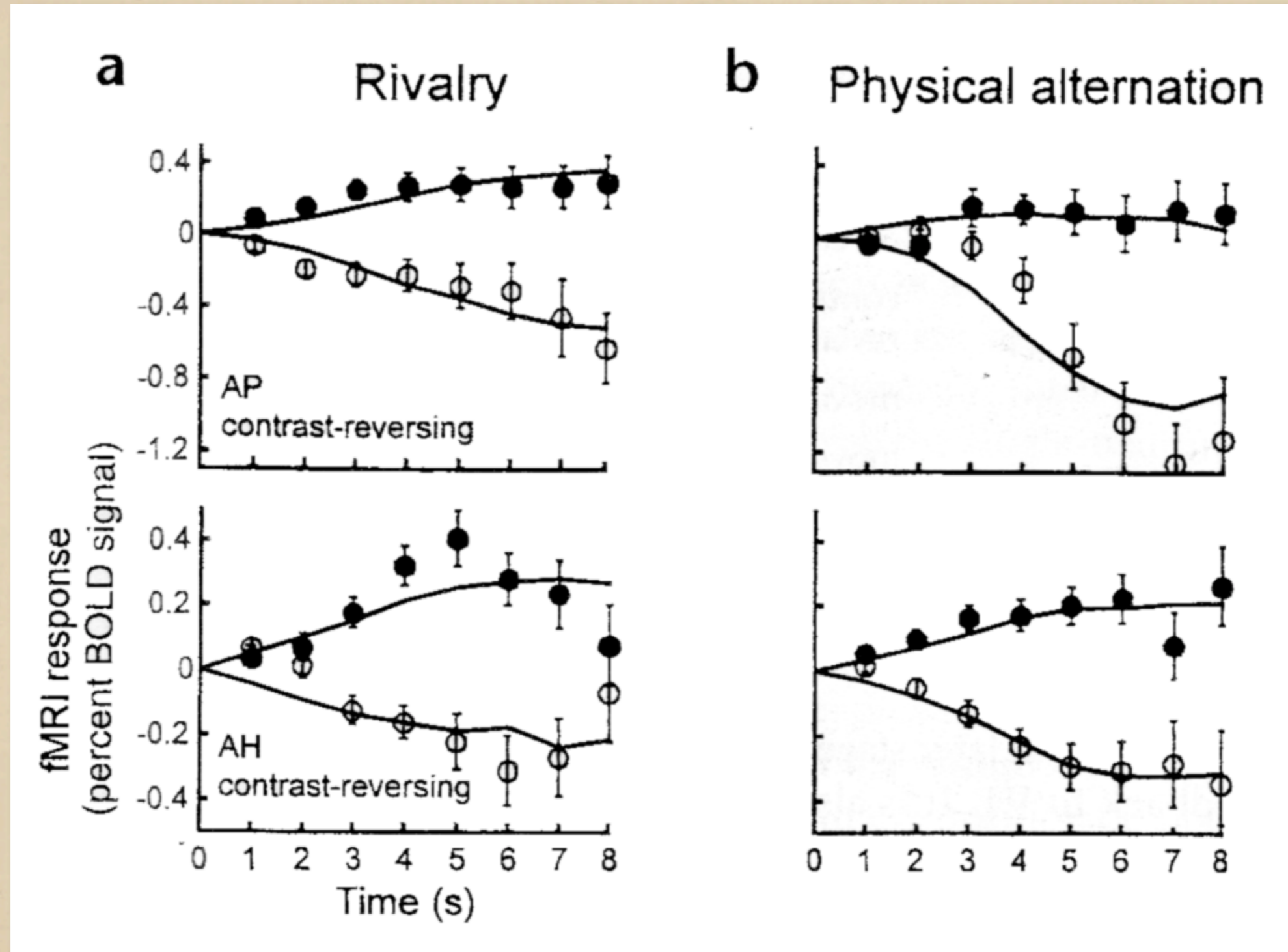

BOLD signals in early visual cortex match perception rather than the physical stimulus

Ress & Heeger 2003

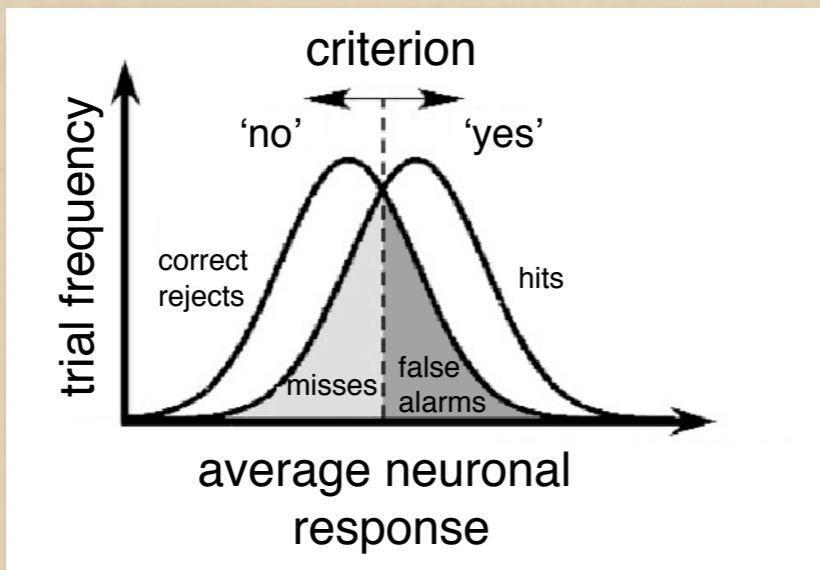

background

background plus target

plaid

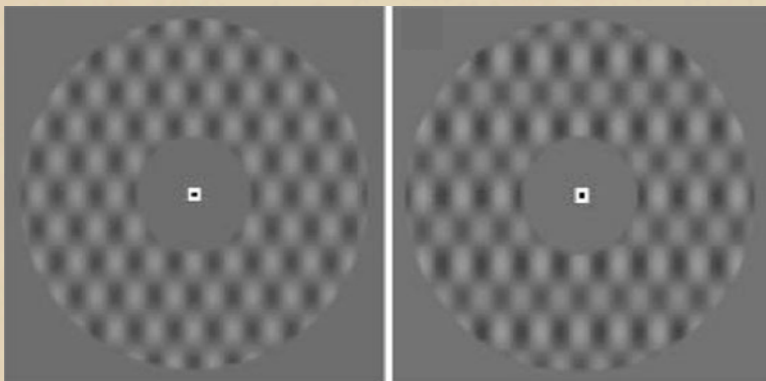

noise

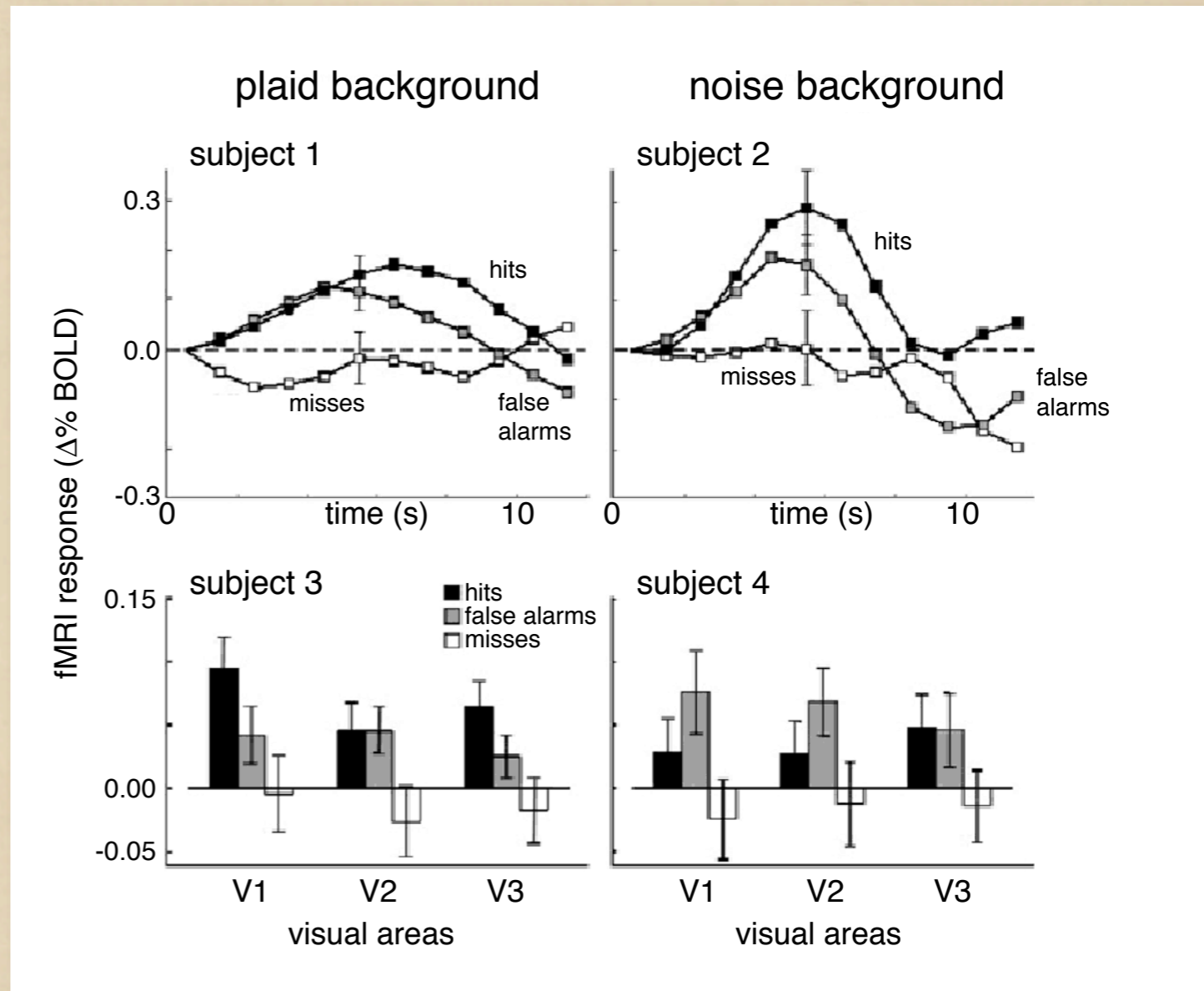
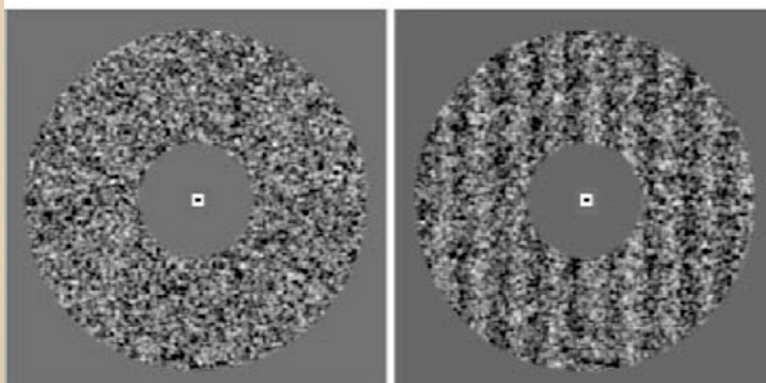

Periphery:

- correlation with neuronal sampling
- correlation with neuronal sensitivity

Central:

- selective effects of ablation
- selective effects of microstimulation
- correlation with neuronal performance
- trial-by-trial correlation with choice
- trial-by-trial correlation with reaction time
- correlation with perception during rivalry
- generation of percepts through microstimulation

Human cortical stimulation sites causing effects
Penfield and Rasmussen, 1950

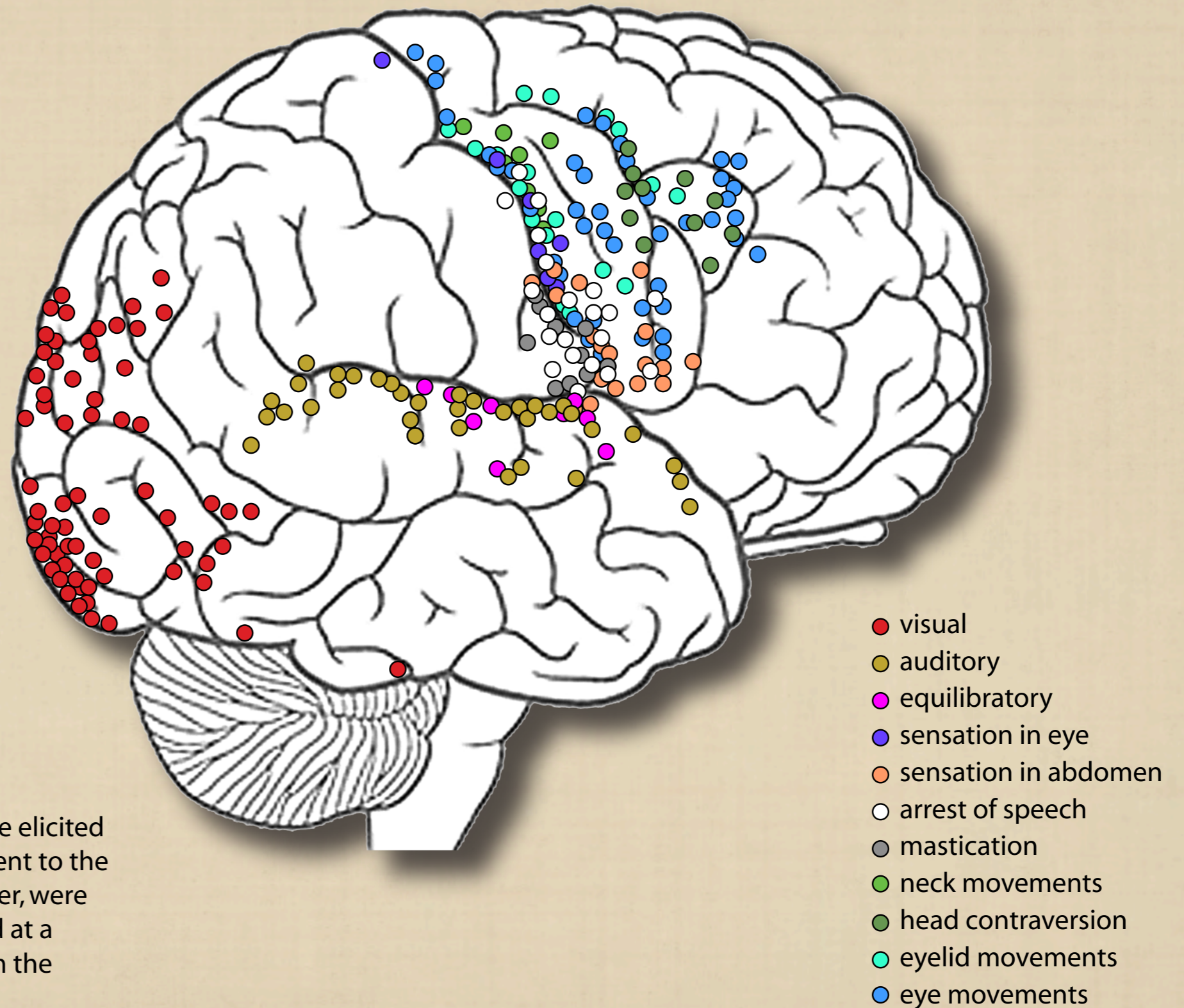

"Somatosensory responses were elicited primarily from the cortex adjacent to the central fissure. ... Rarely, however, were sensory responses encountered at a distance greater than 1 cm from the central fissure."

Detection of Microstimulation of Human Visual Cortex

Murphey et al. (2009)

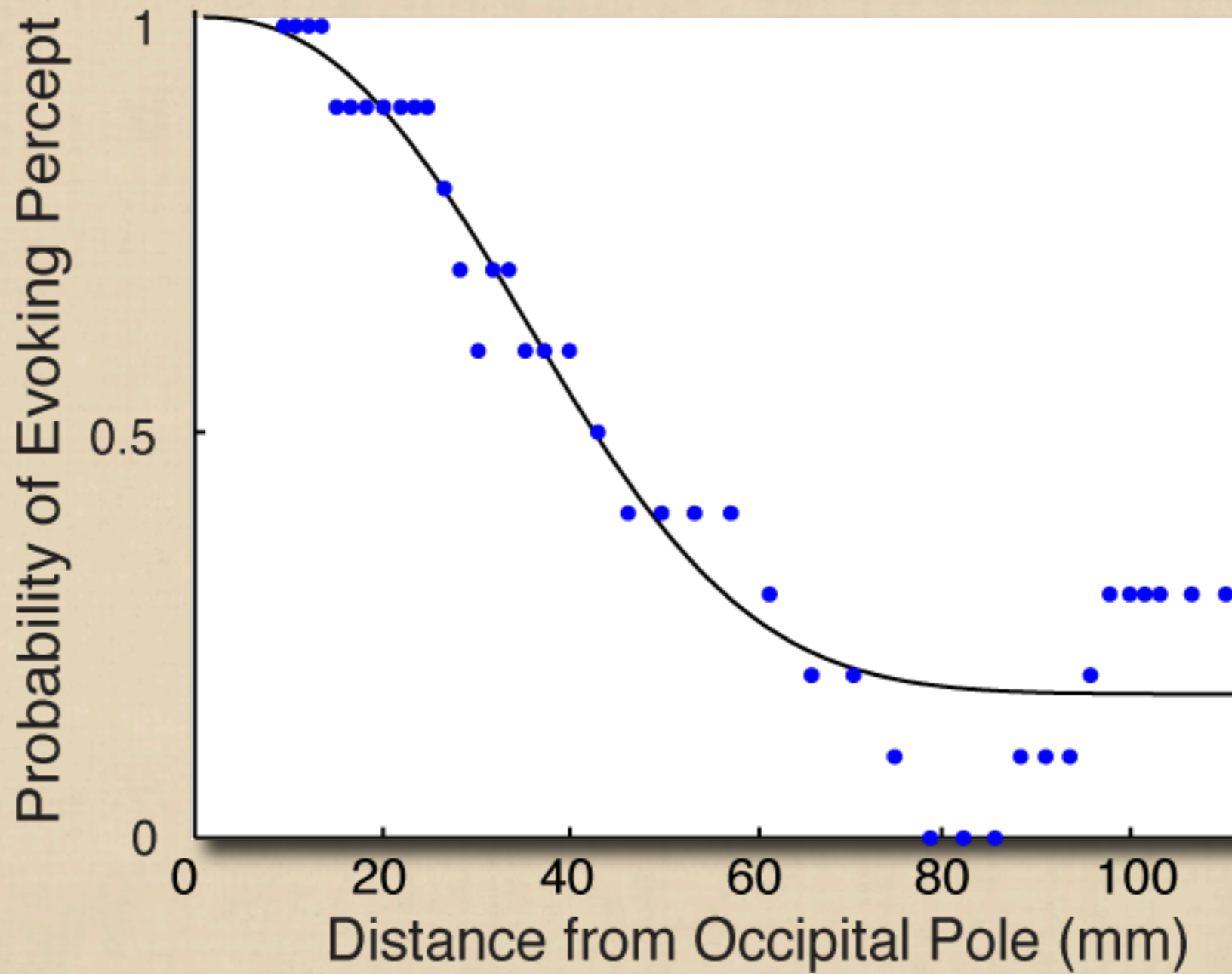

Parietal Pathway

Temporal Pathway

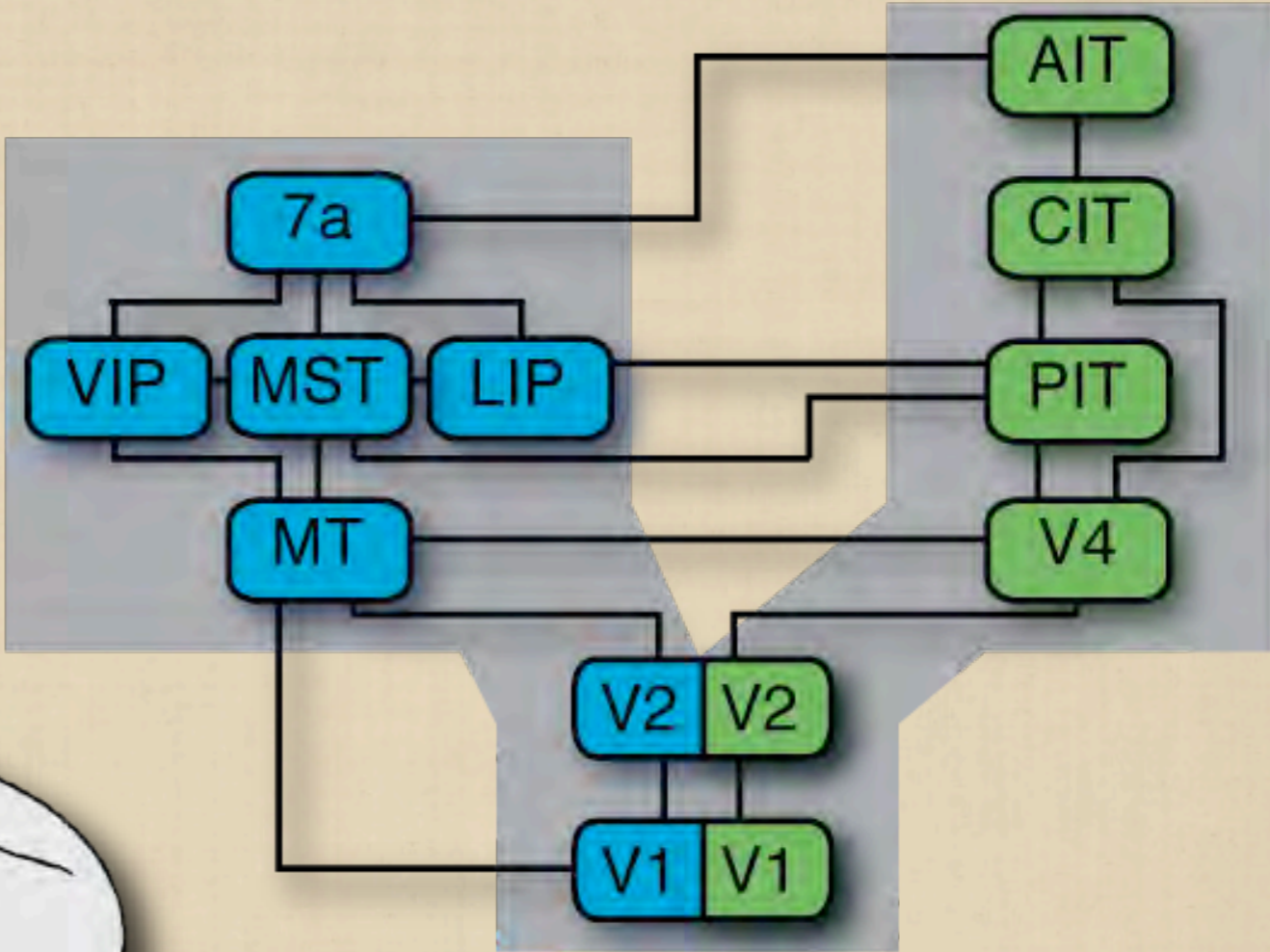

Parietal Pathway

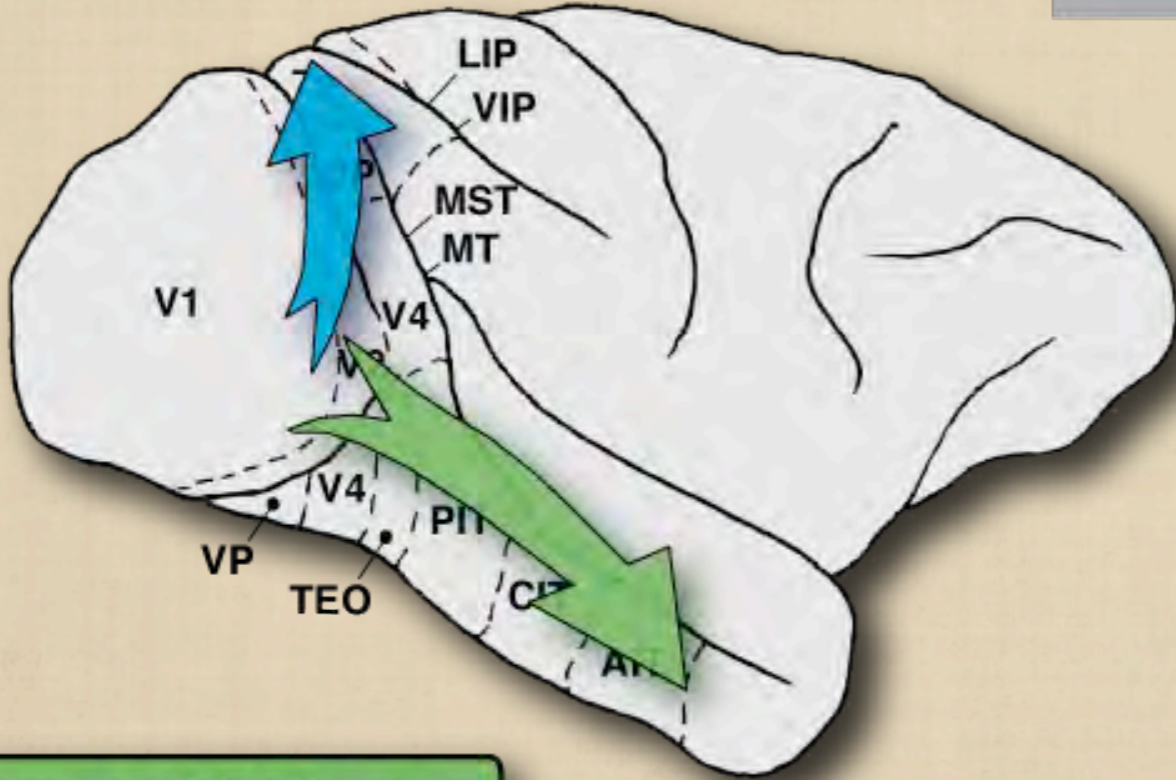

Temporal Pathway

Psychometric function for detecting microstimulation at a site in monkey V1

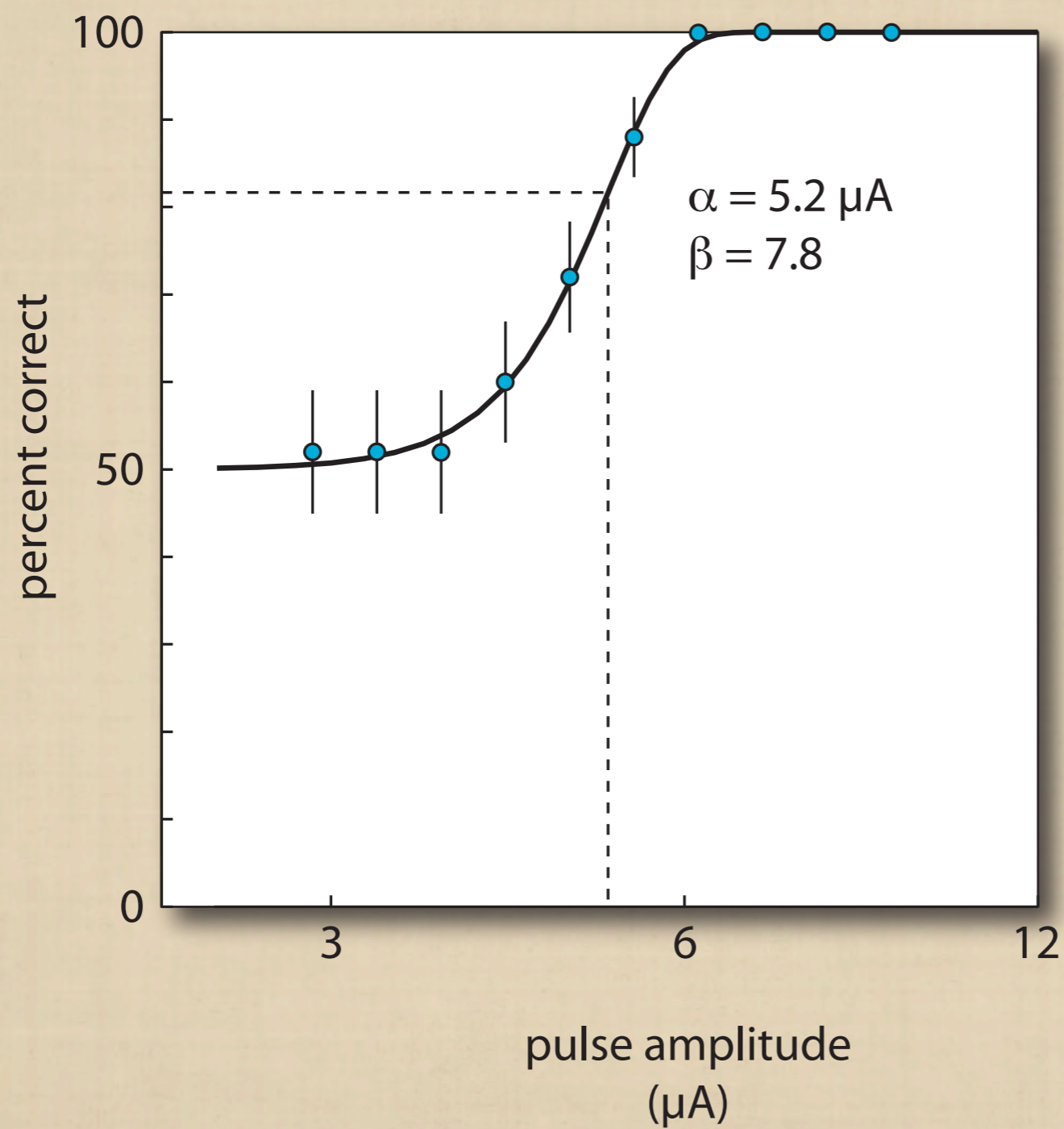

$$p = 1.0 - 0.5 e^{-\left(\frac{c}{\alpha}\right)^\beta}$$

Thresholds for detecting electrical microstimulation

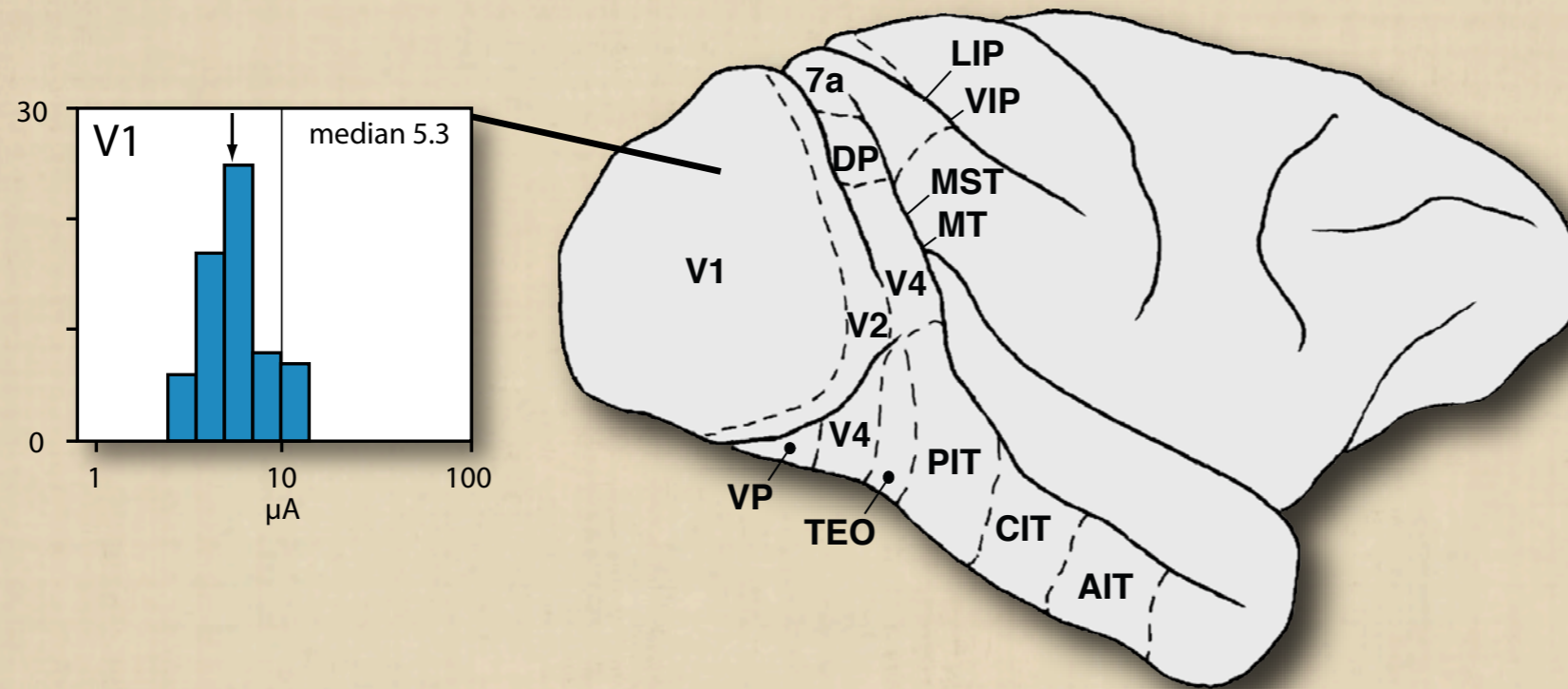

Thresholds for detecting electrical microstimulation

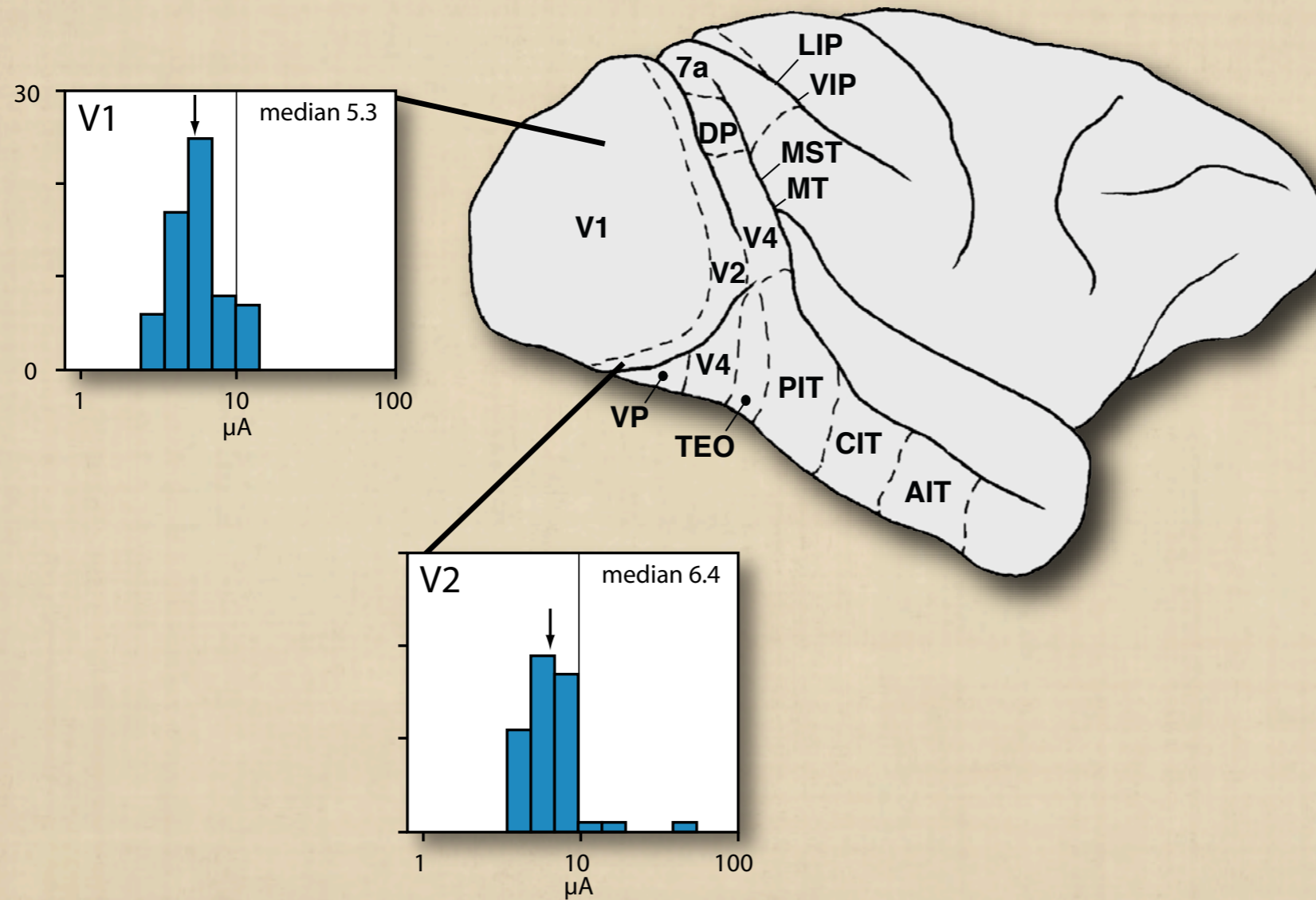

Thresholds for detecting electrical microstimulation

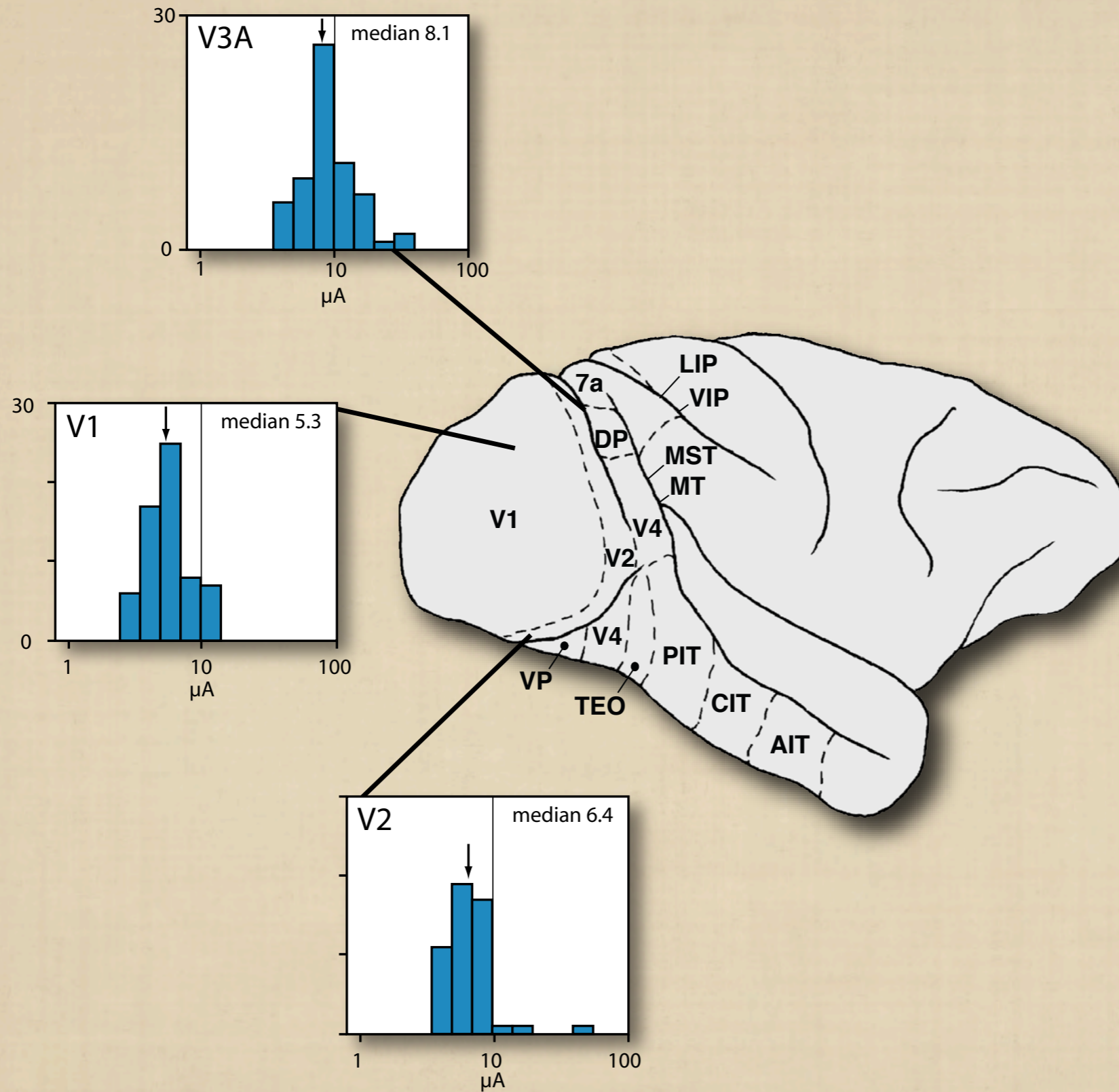

Thresholds for detecting electrical microstimulation

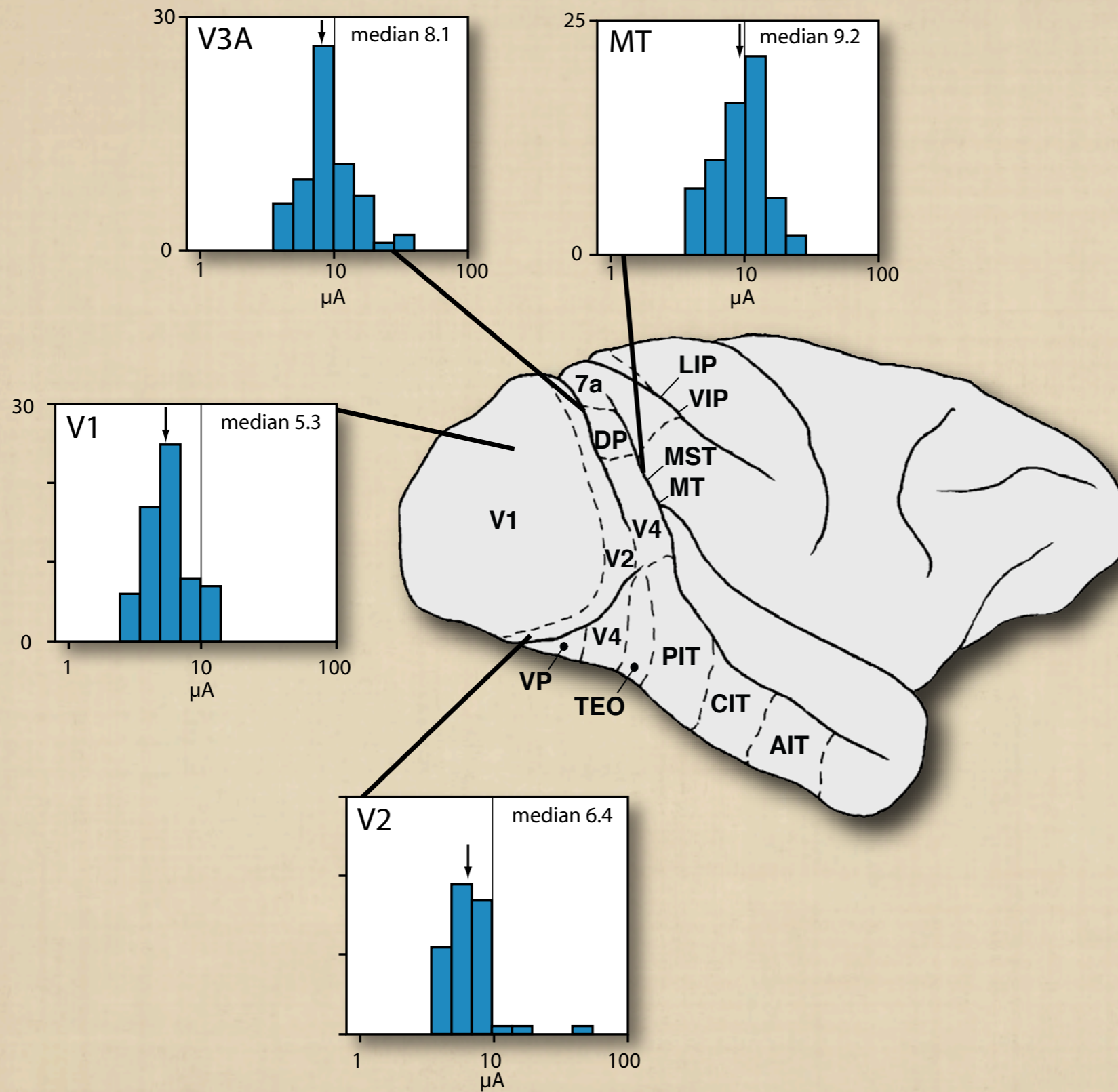

Thresholds for detecting electrical microstimulation

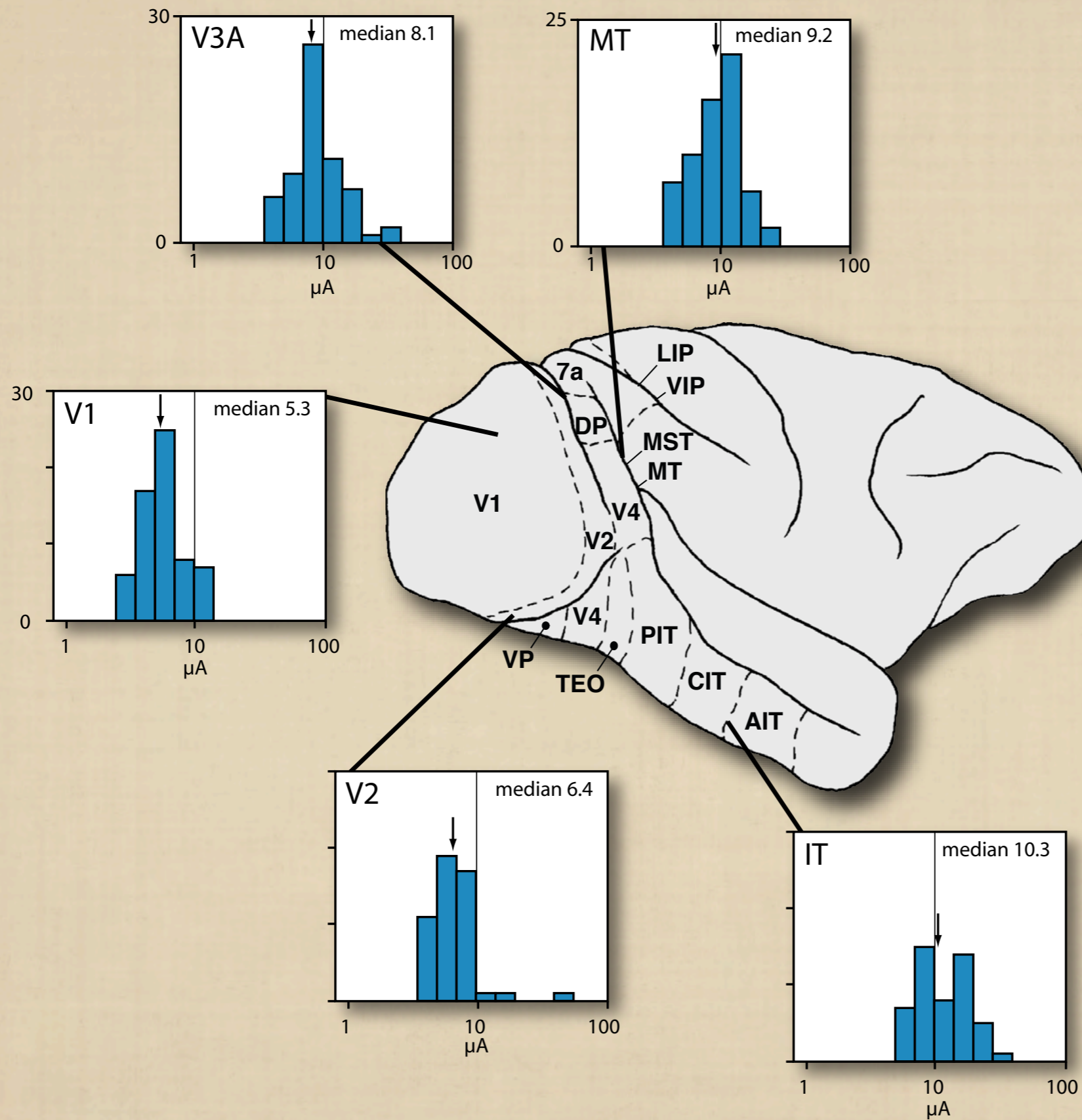

Thresholds for detecting electrical microstimulation

