

Attention

March 4, 2009

John Maunsell

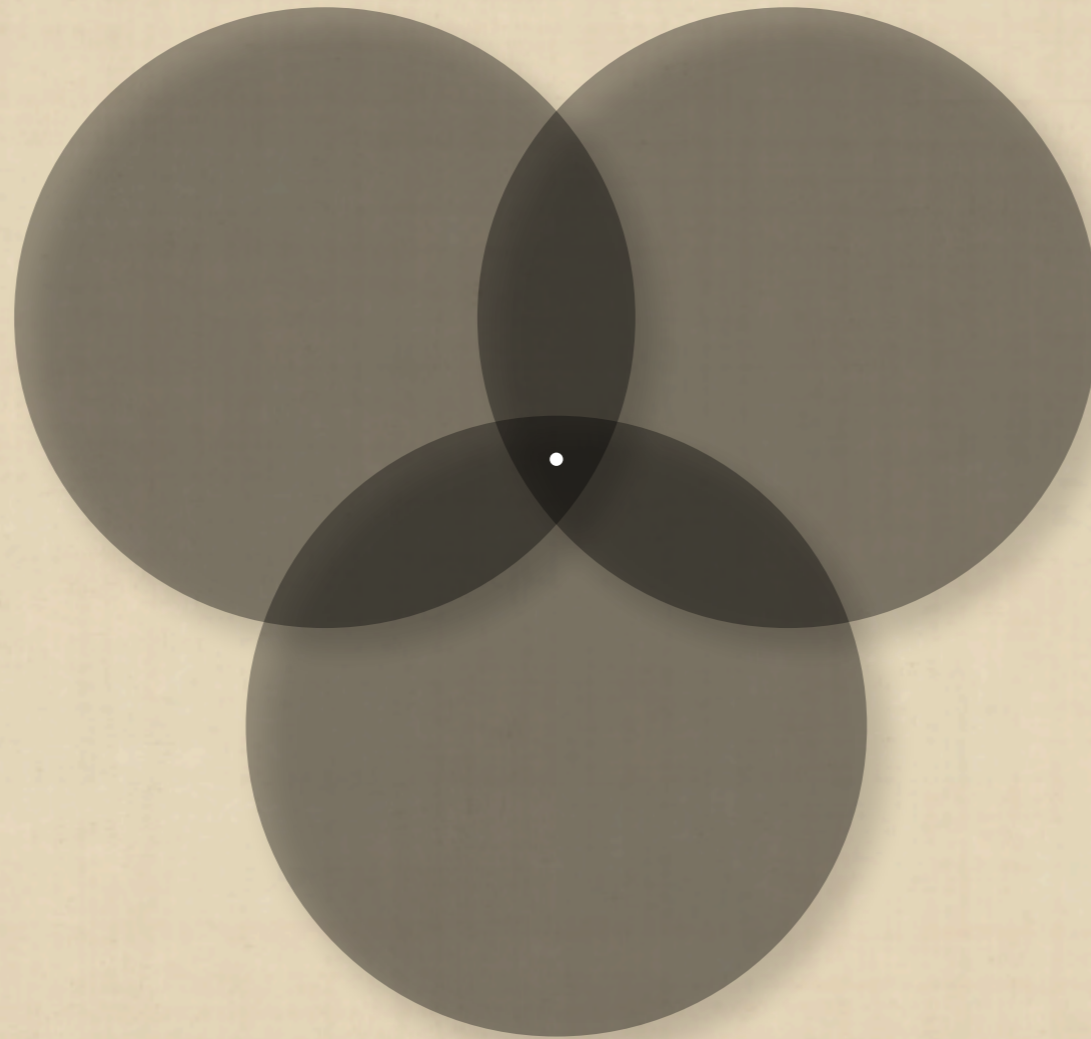

Mitchell, JF, Sundberg, KA, Reynolds, JH (2007) Differential attention-dependent response modulation across cell classes in macaque visual area V4. *Neuron*, 55:131–141.

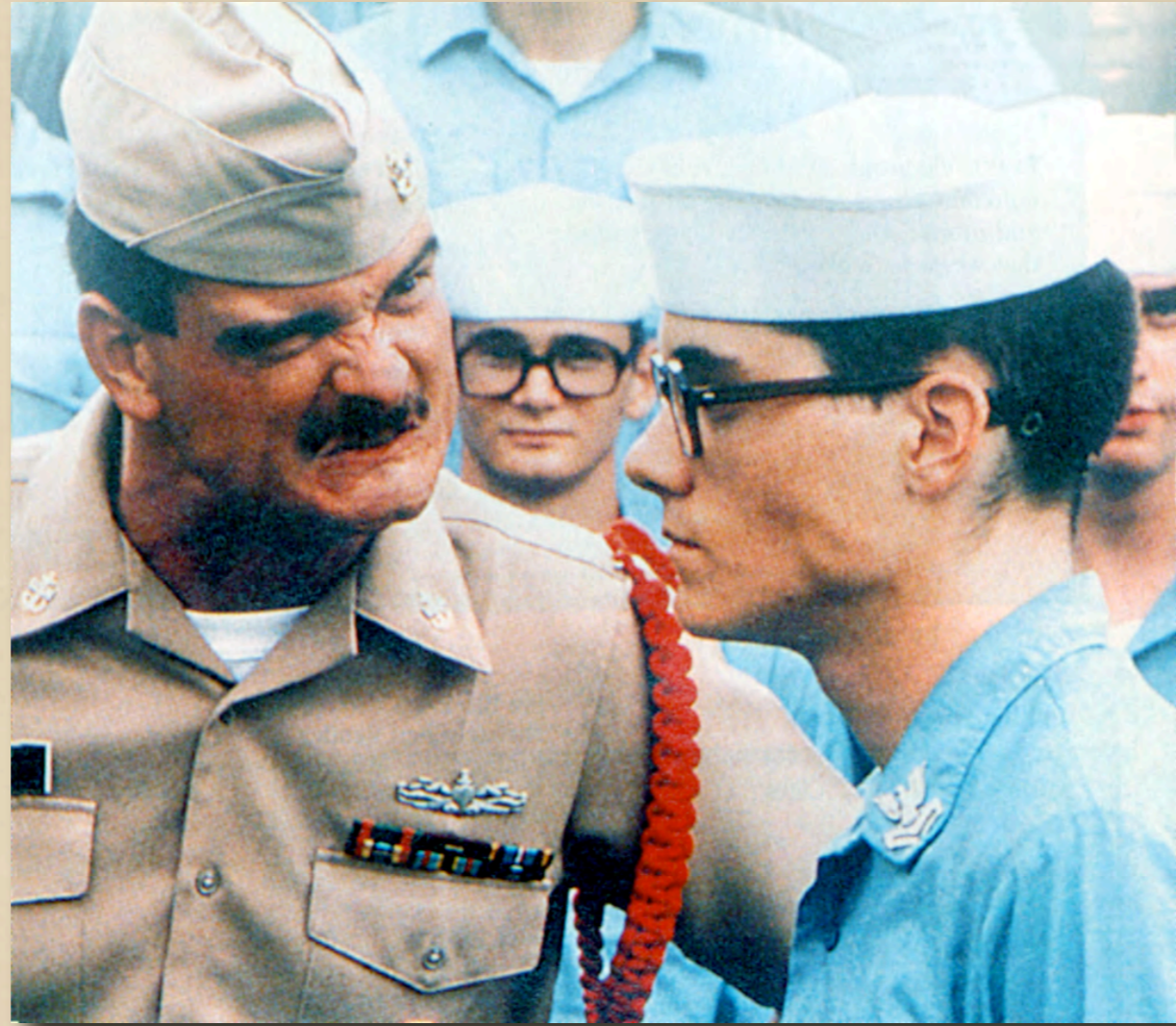



Moore et al.

Parietal Pathway

Temporal Pathway

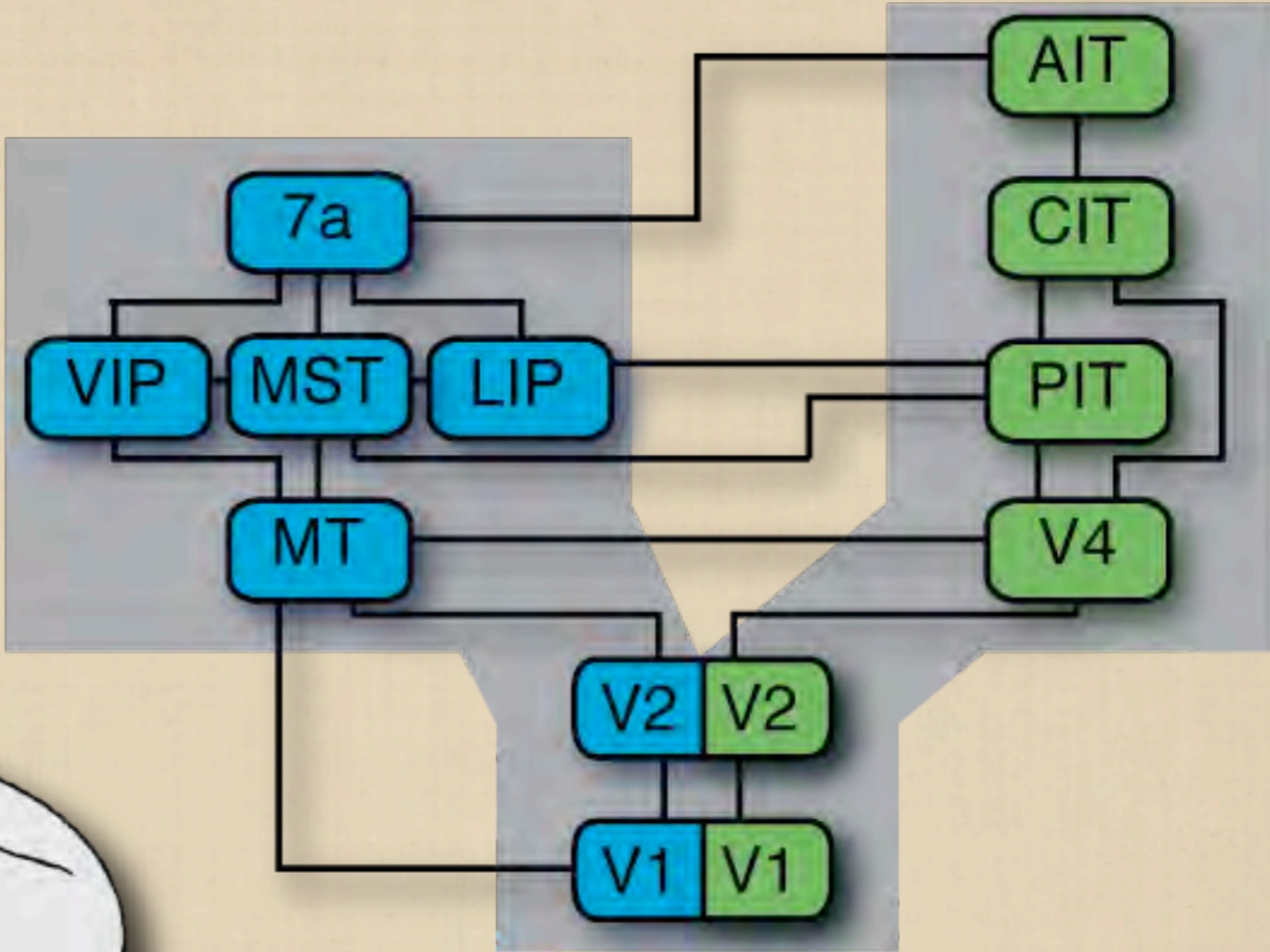

Parietal Pathway

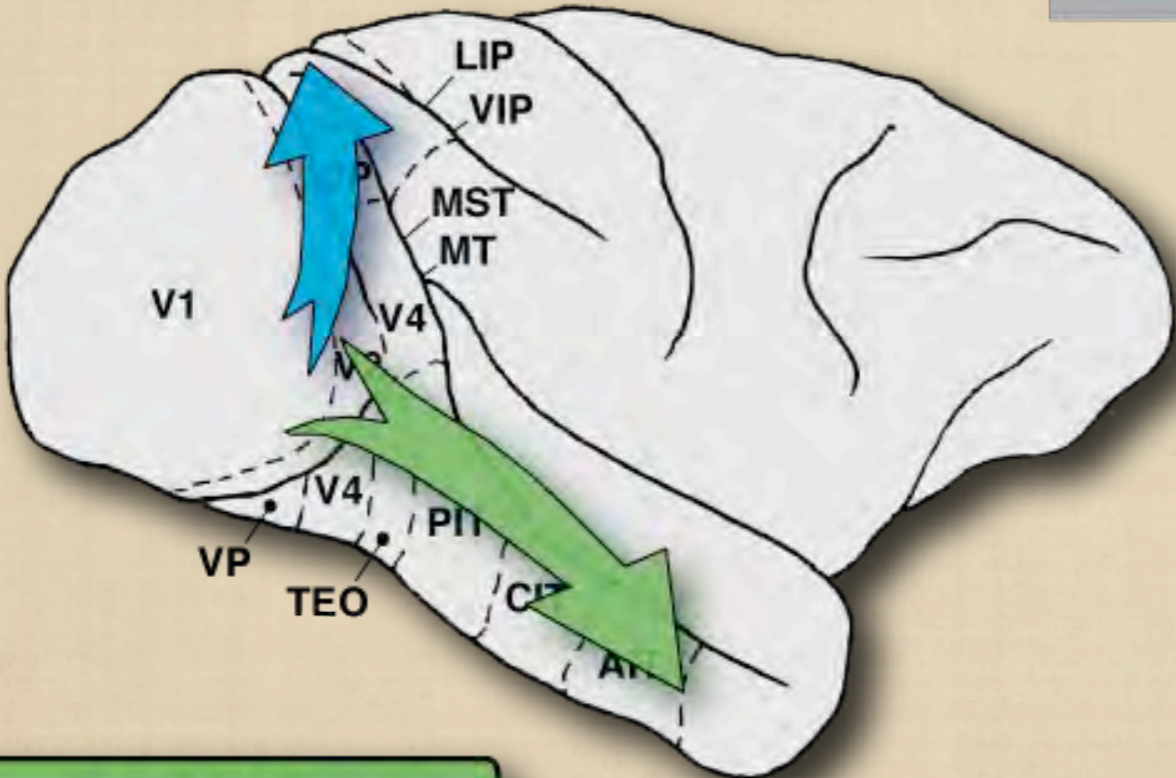

Temporal Pathway

Spatial attention task

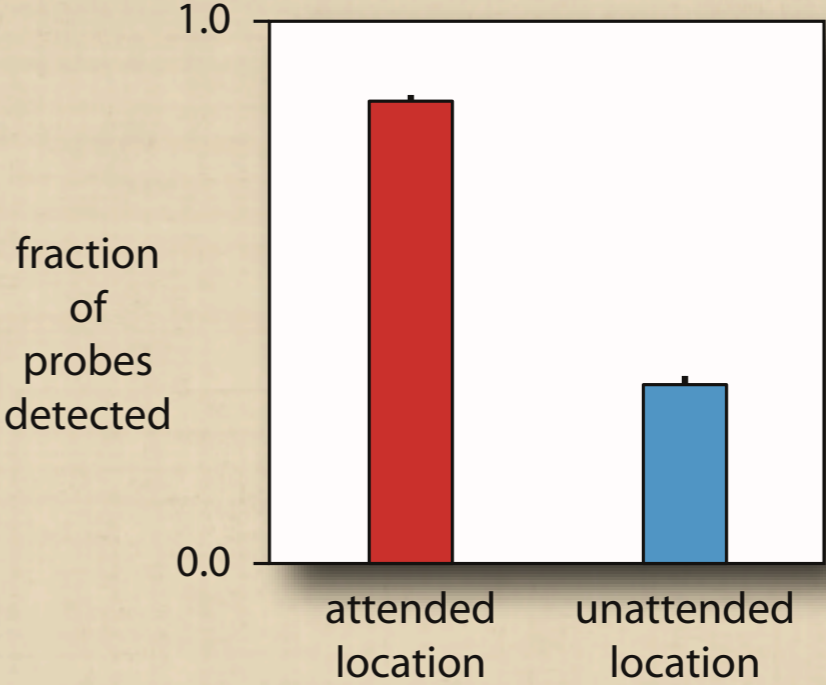
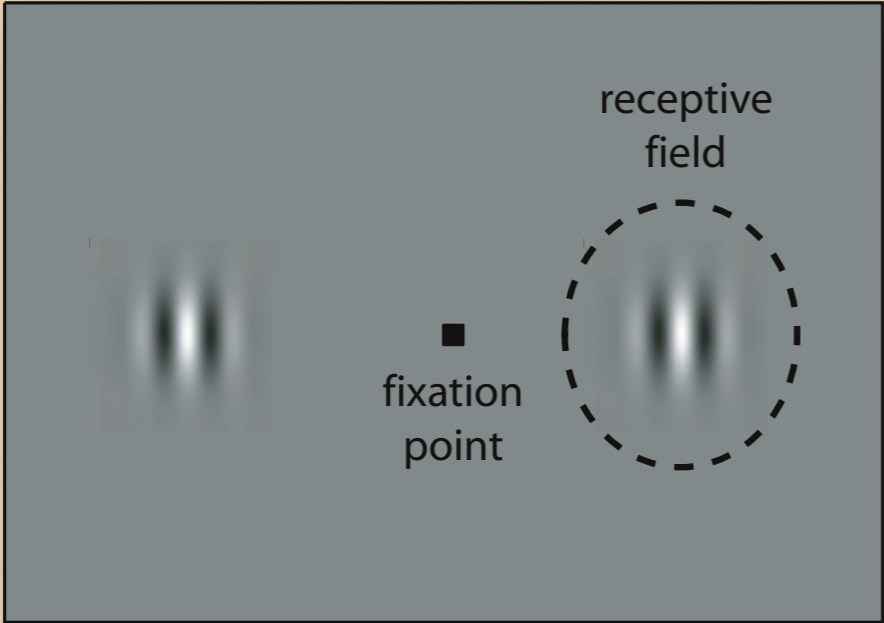

attend to other stimulus

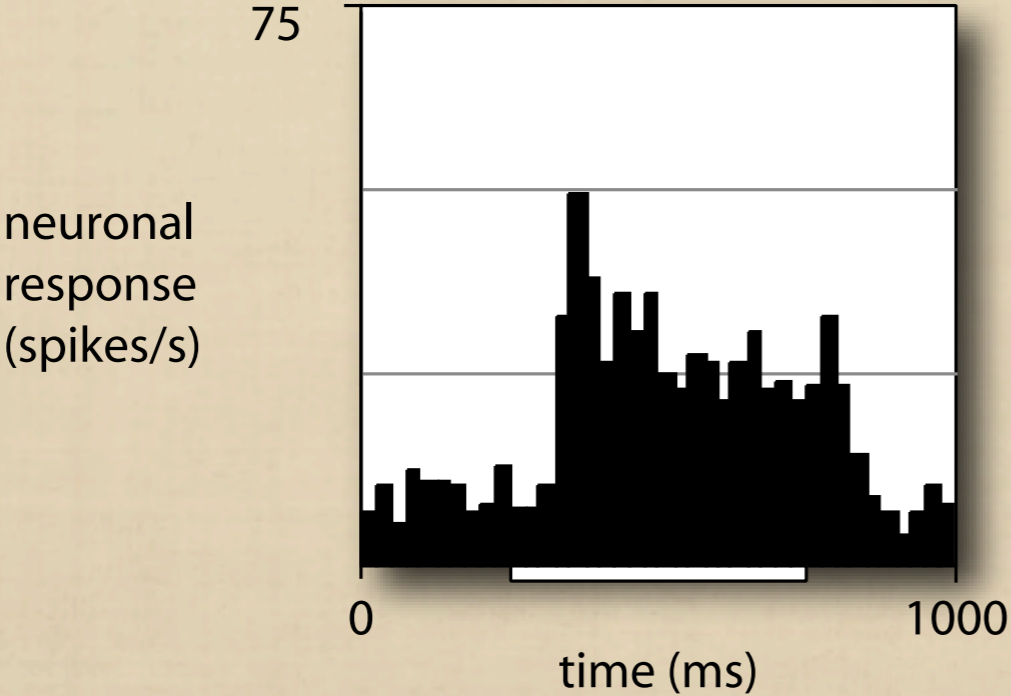

attend to receptive field stimulus

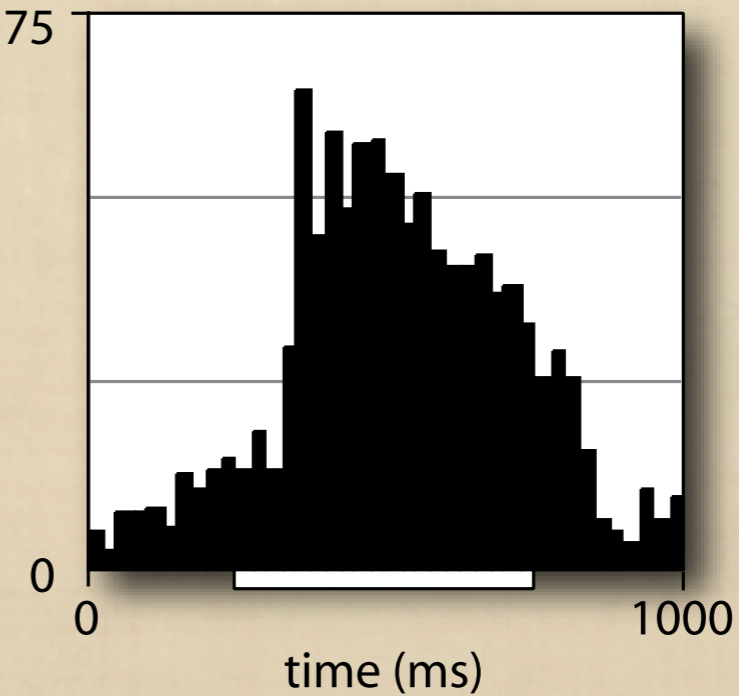

Effect of behavioral state in Area 7a

Mountcastle, Andersen & Motter 1981

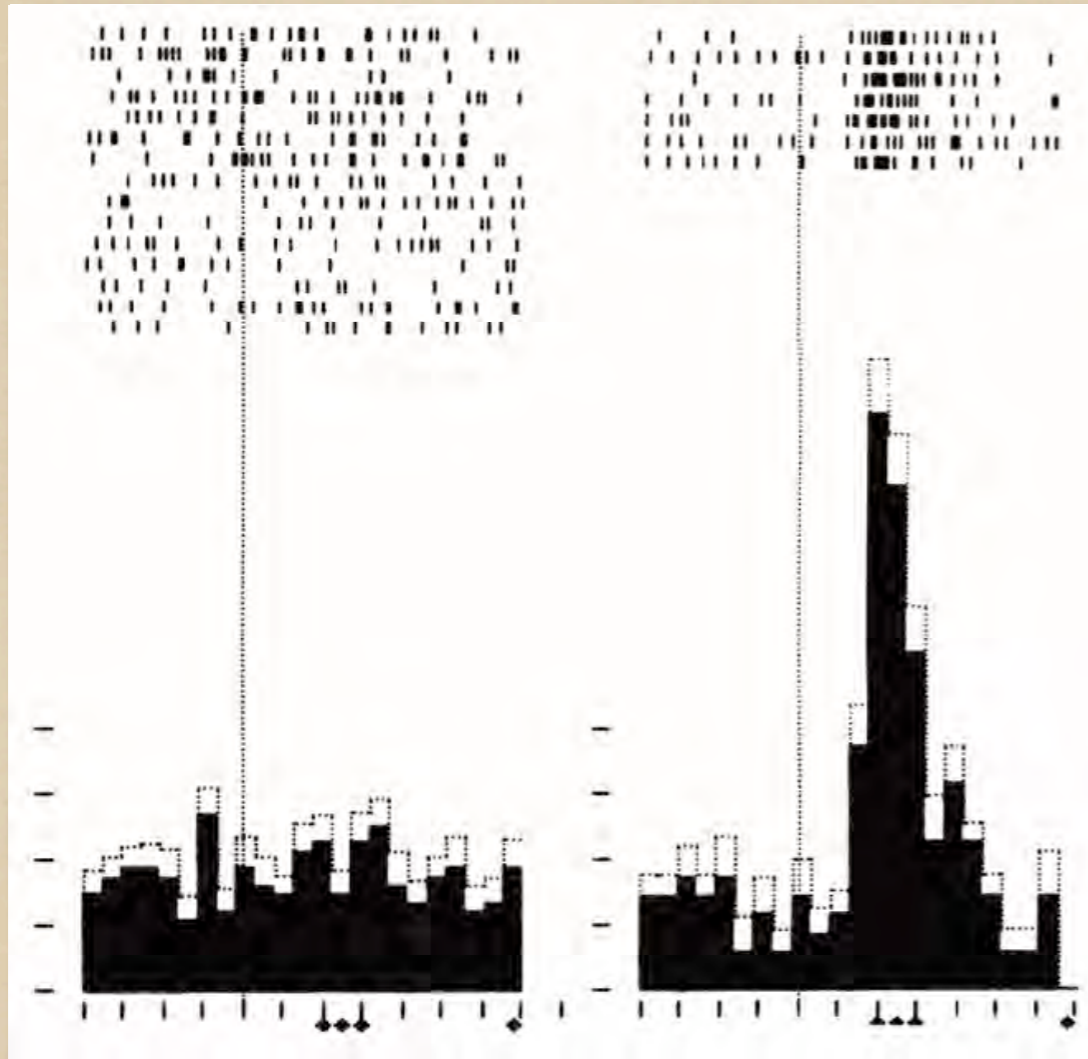

Bushnell, Goldberg & Robinson 1981

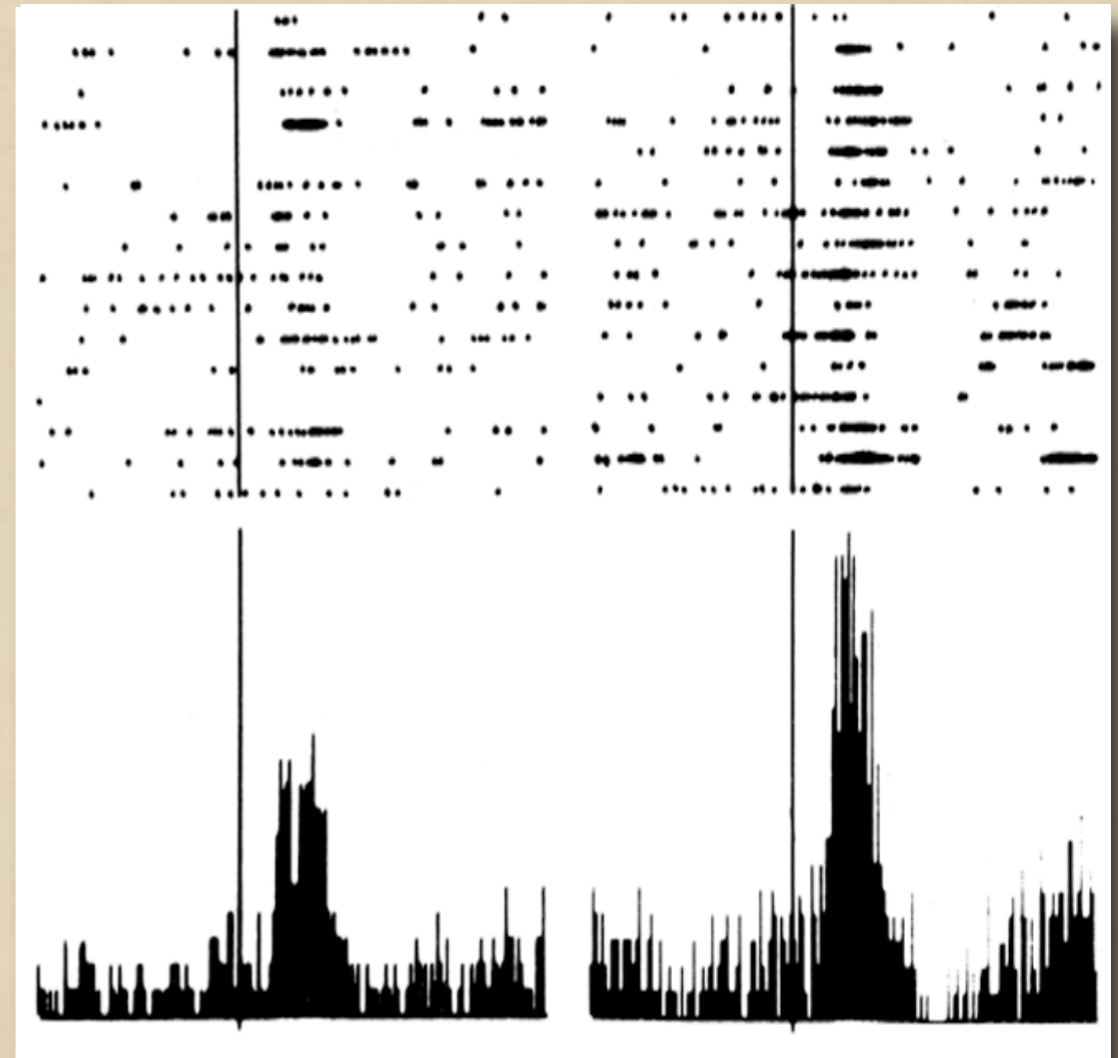

Parietal Pathway

Temporal Pathway

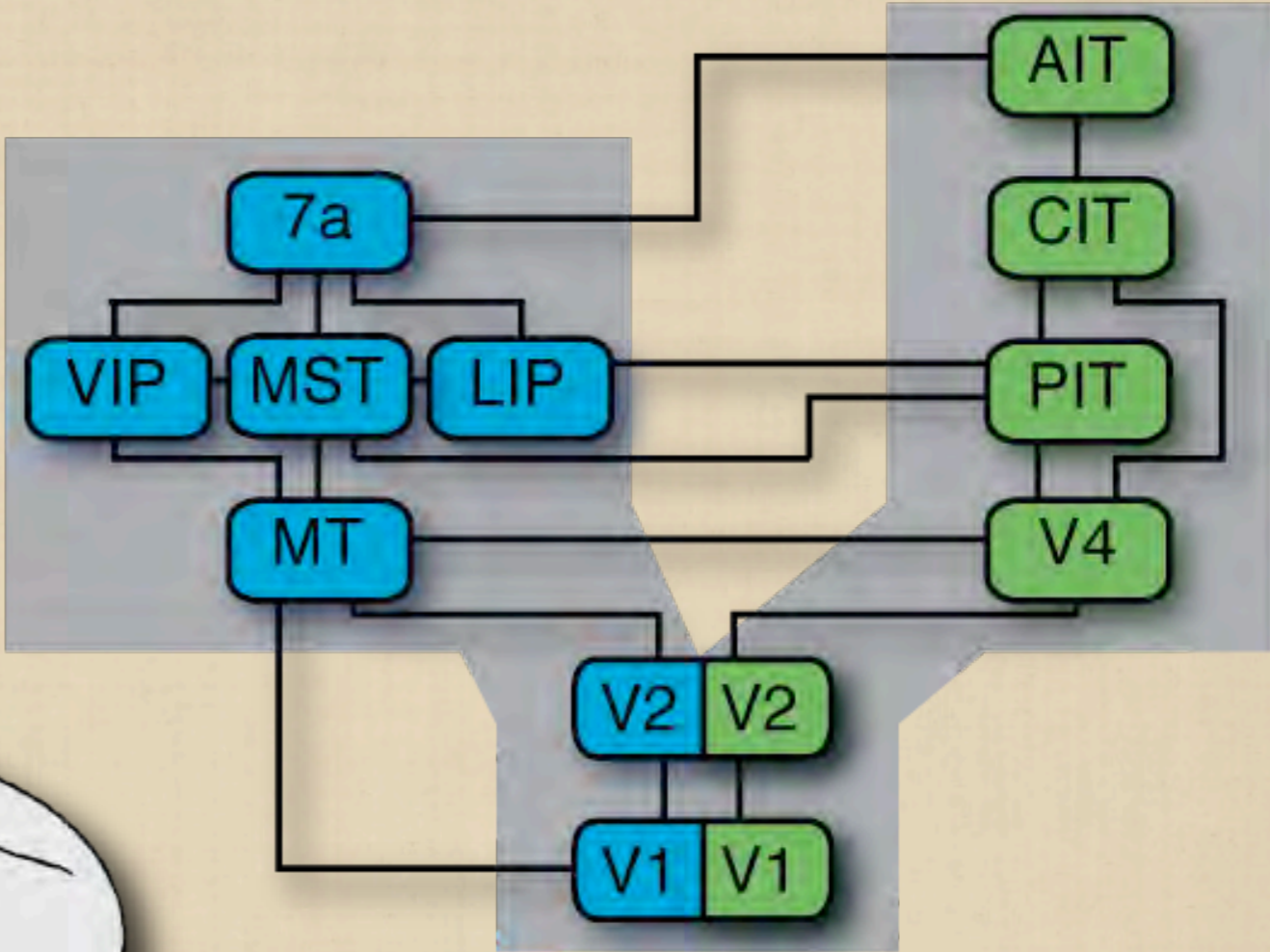

Parietal Pathway

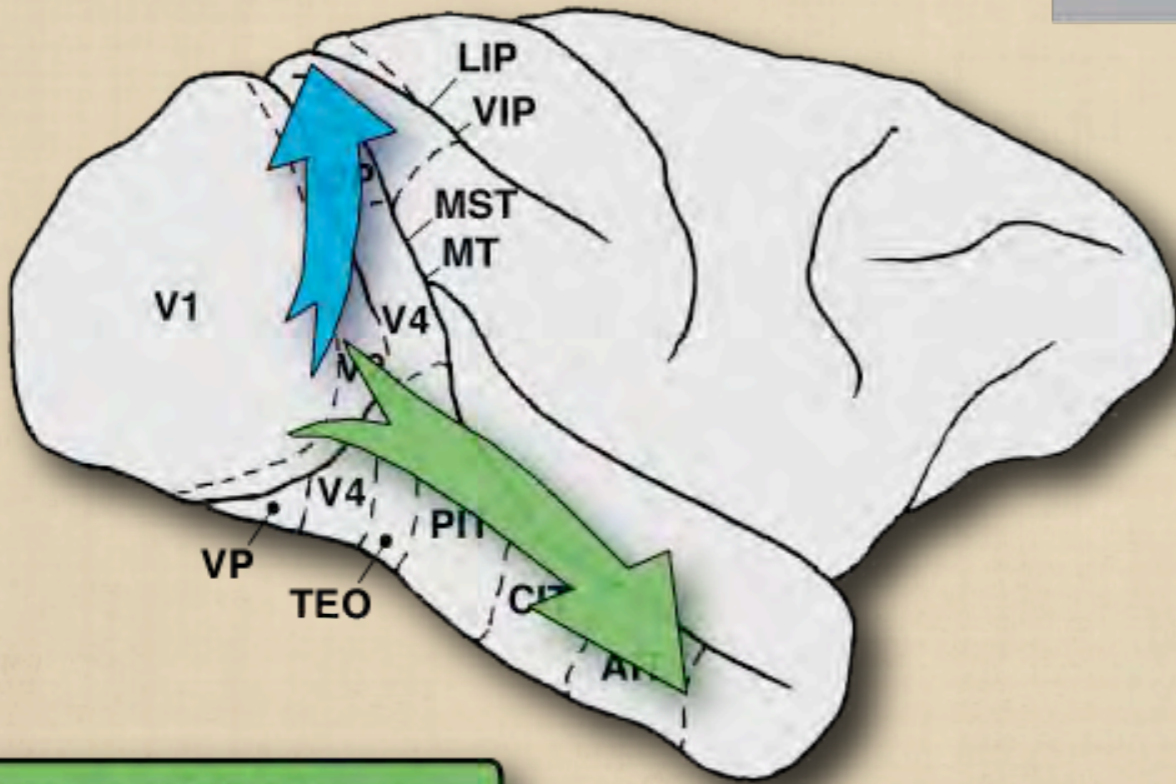

Temporal Pathway

Task difficulty modulates neuronal responses in Area V4

Spitzer, Moran & Desimone 1988

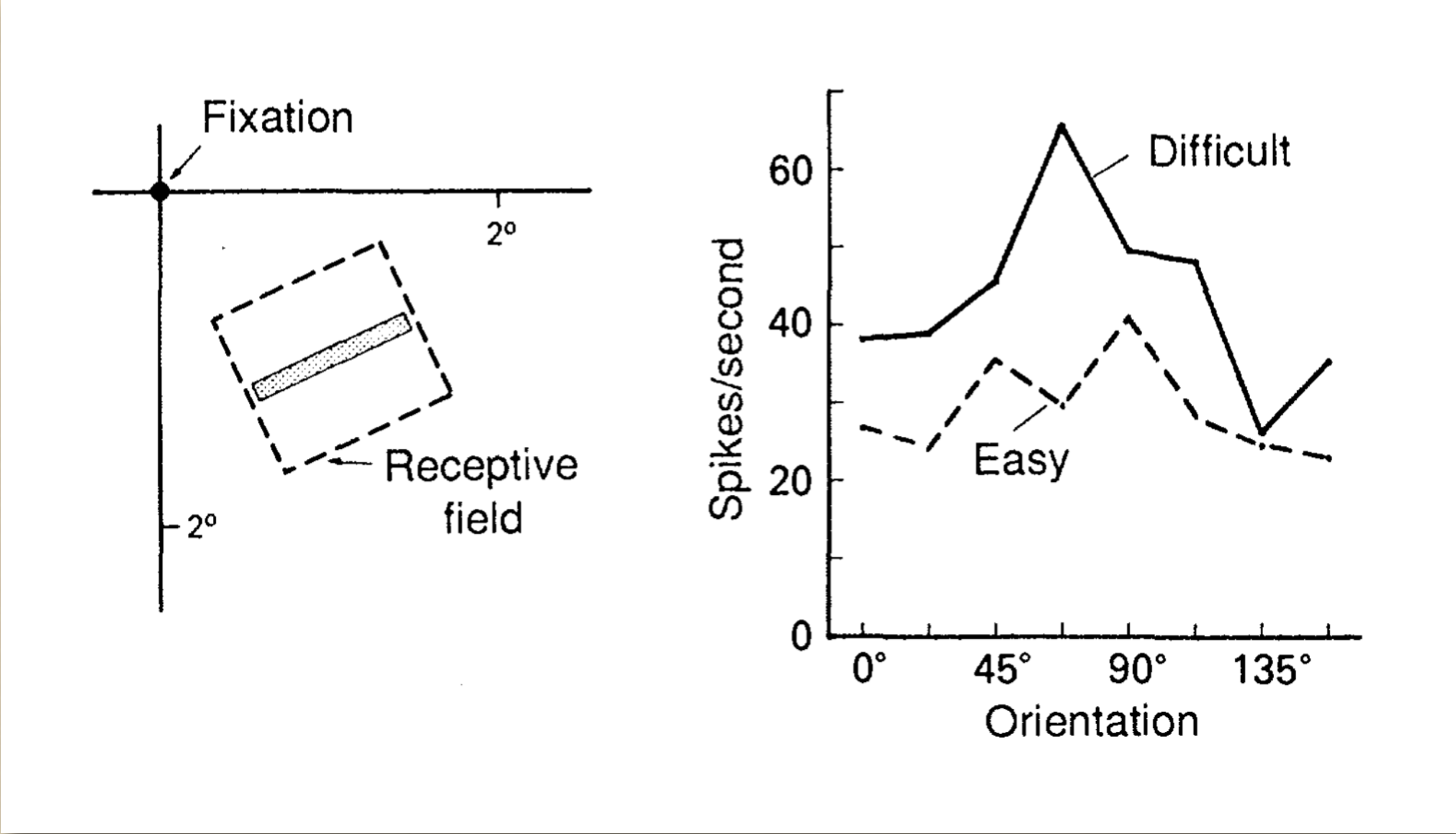

Detecting orientation change

Boudreau et al. (2006)

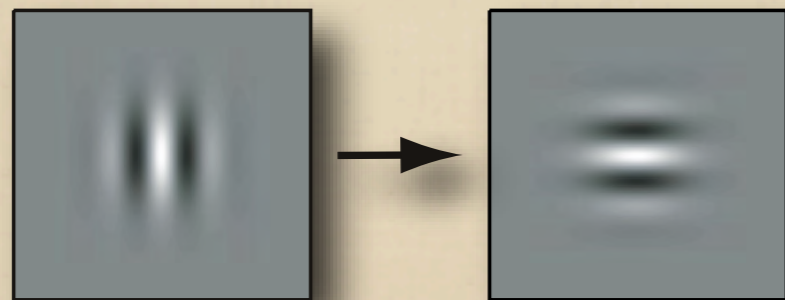
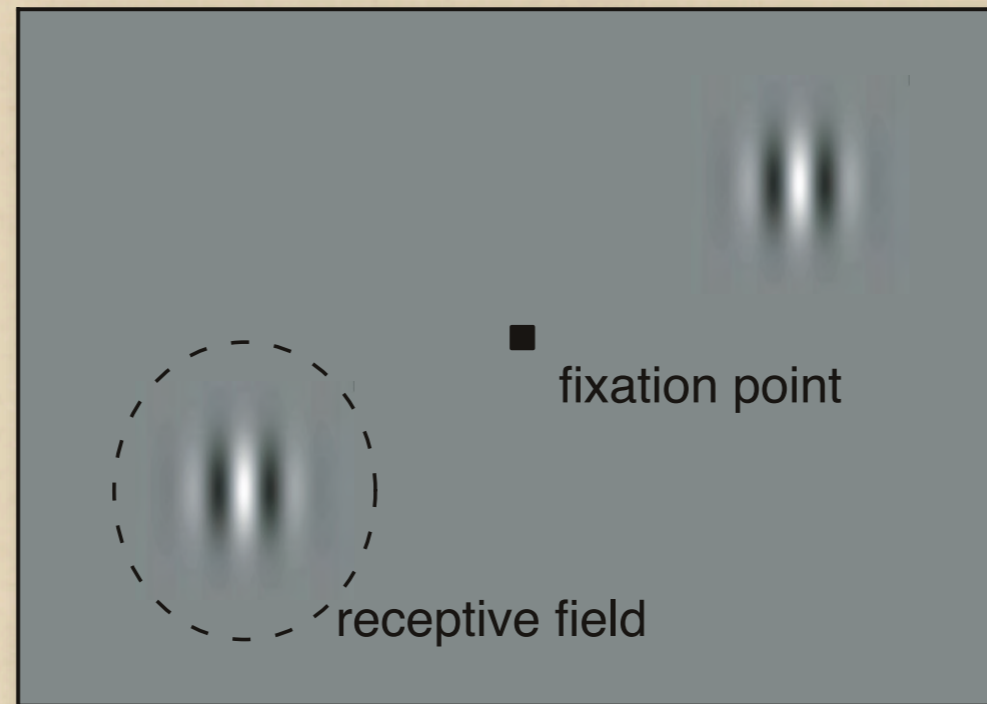

easy mode (90°)

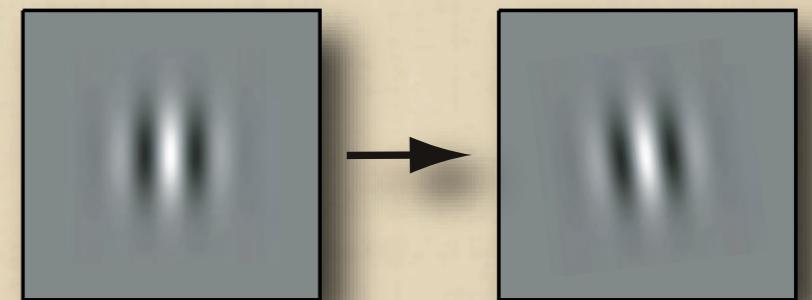

difficult mode ($\sim 10^\circ$)

Task difficulty is determined by the size of orientation change

Boudreau et al. (2006)

easy

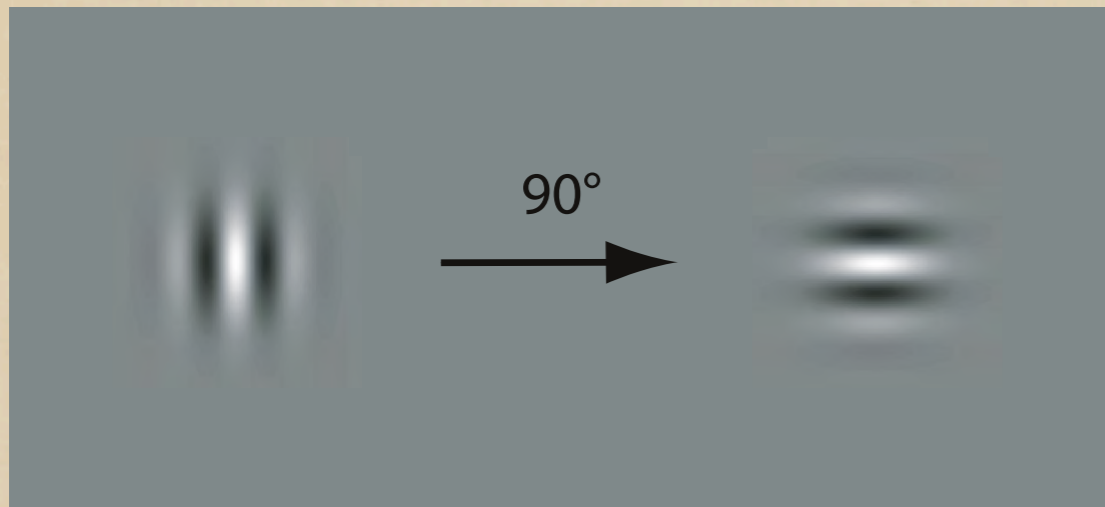

difficult

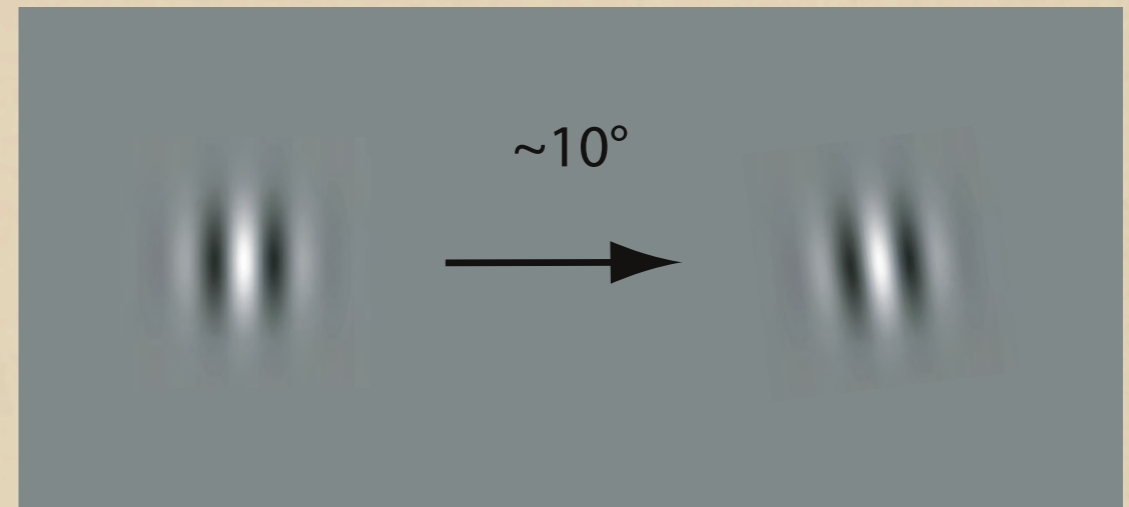

Task difficulty is determined by the size of orientation change

Boudreau et al. (2006)

easy



difficult

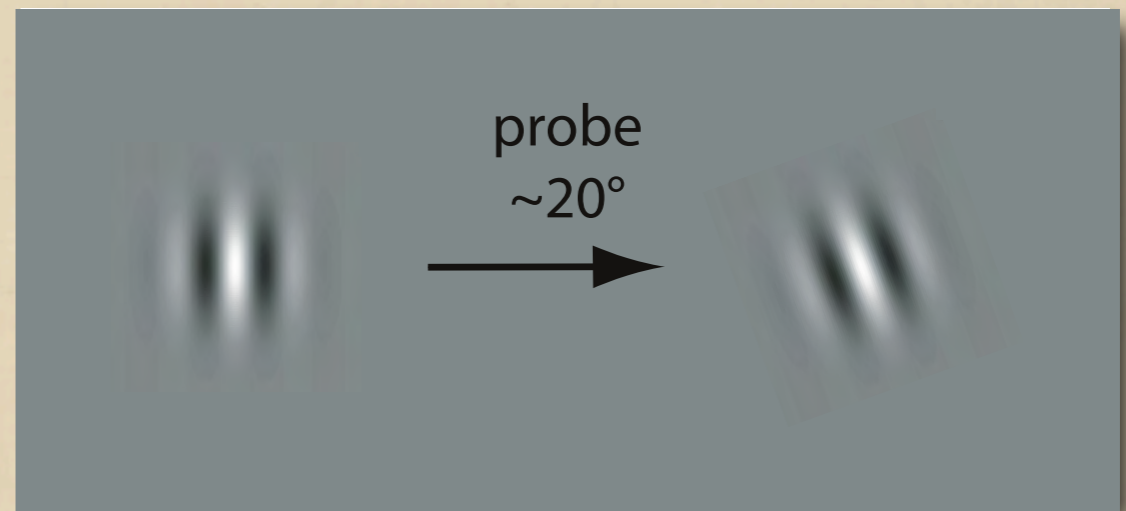
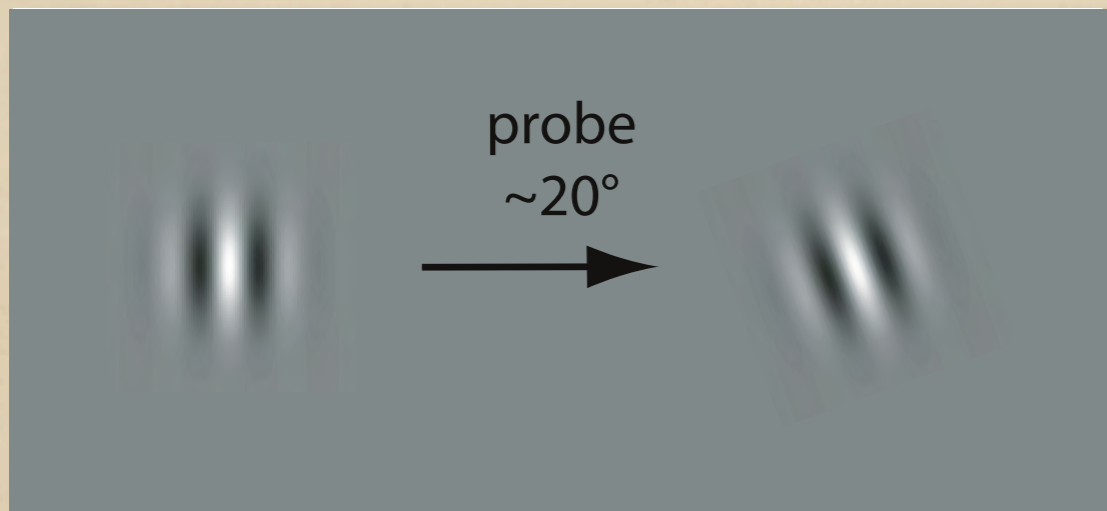
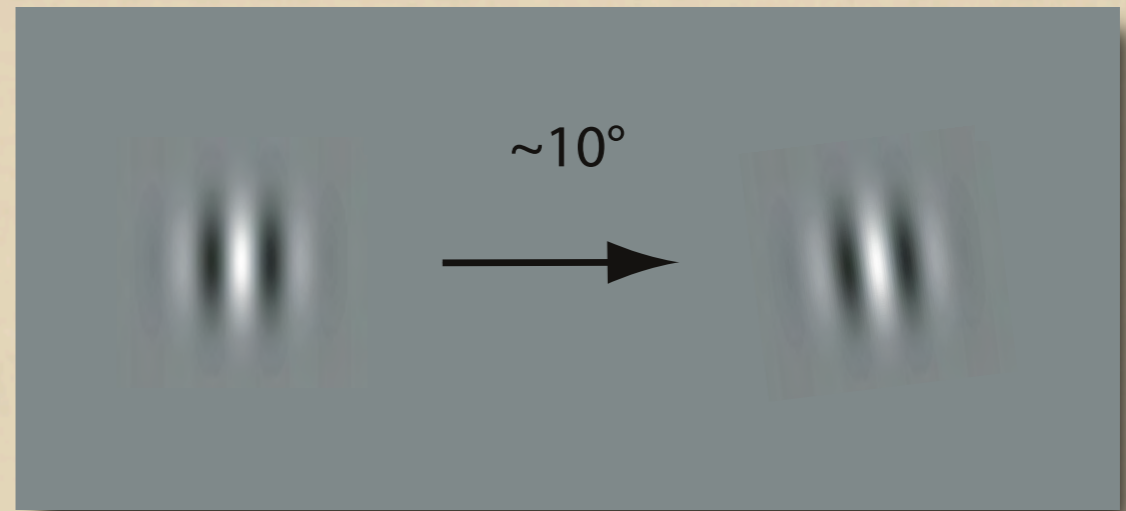

Behavioral performance

Boudreau et al. (2006)

performance on probes
(proportion correct)

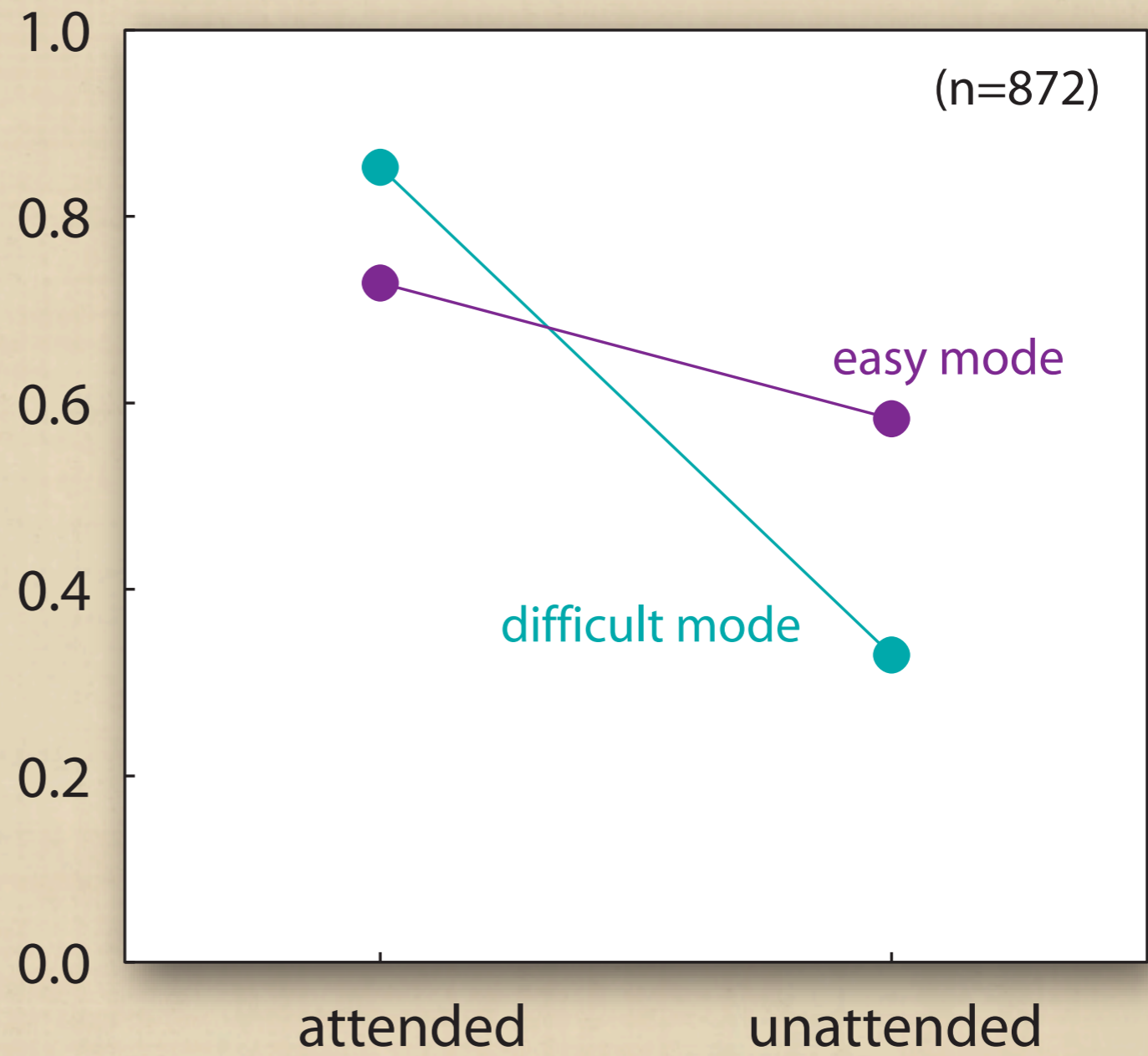

Example V4 neuron response to preferred orientation

Boudreau et al. (2006)

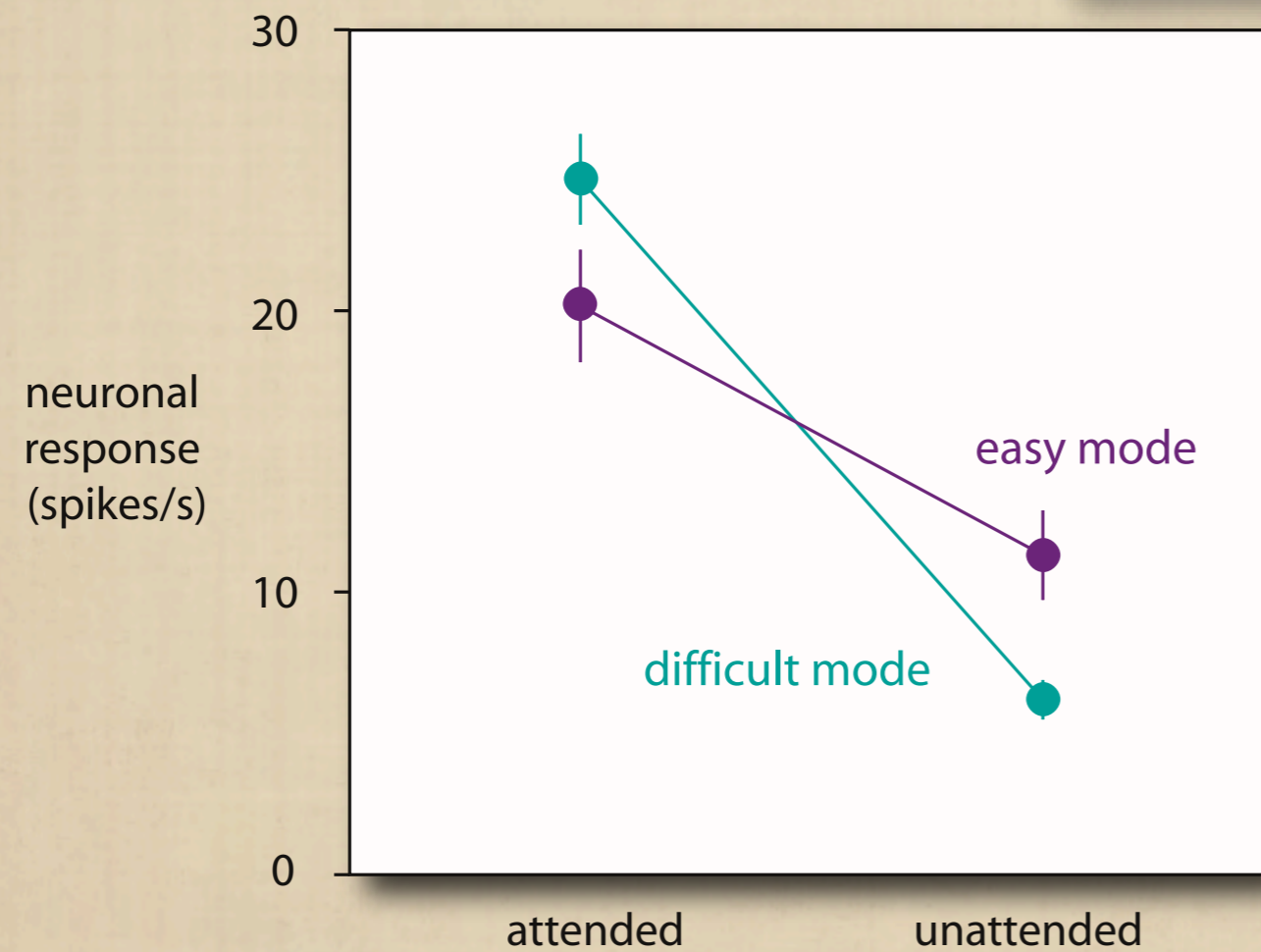
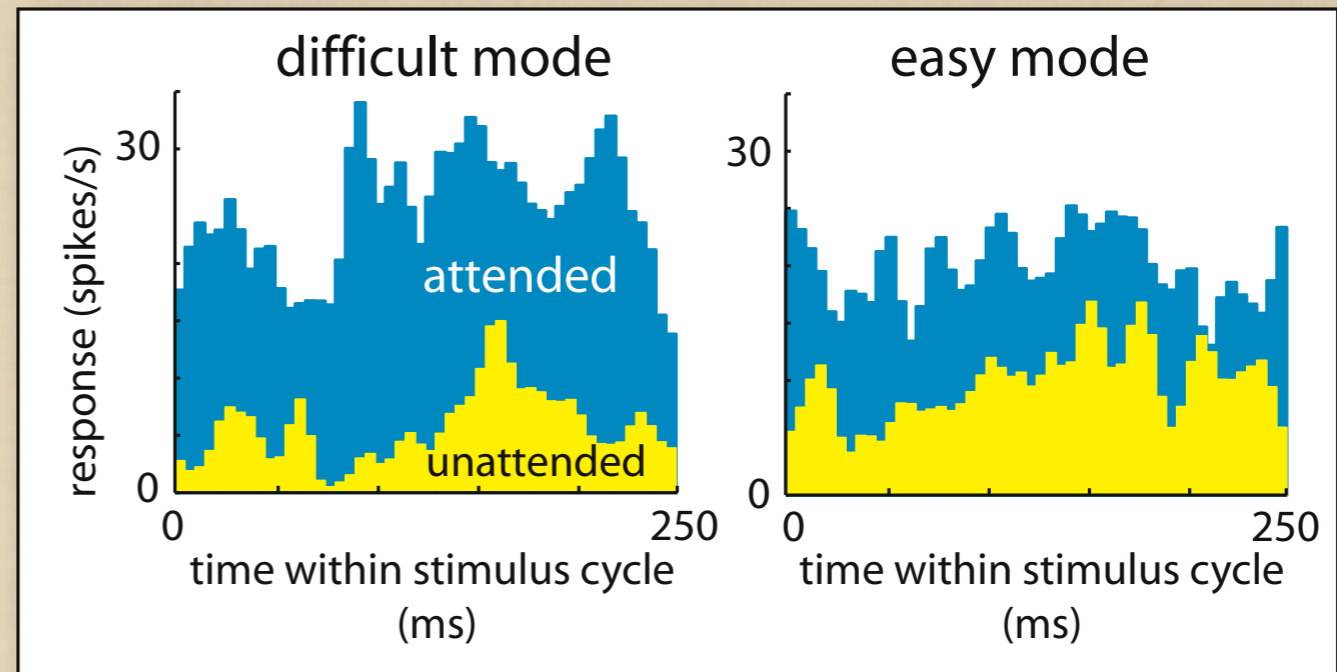

Distribution of attentional modulation in V4

Boudreau et al. (2006)

easy mode

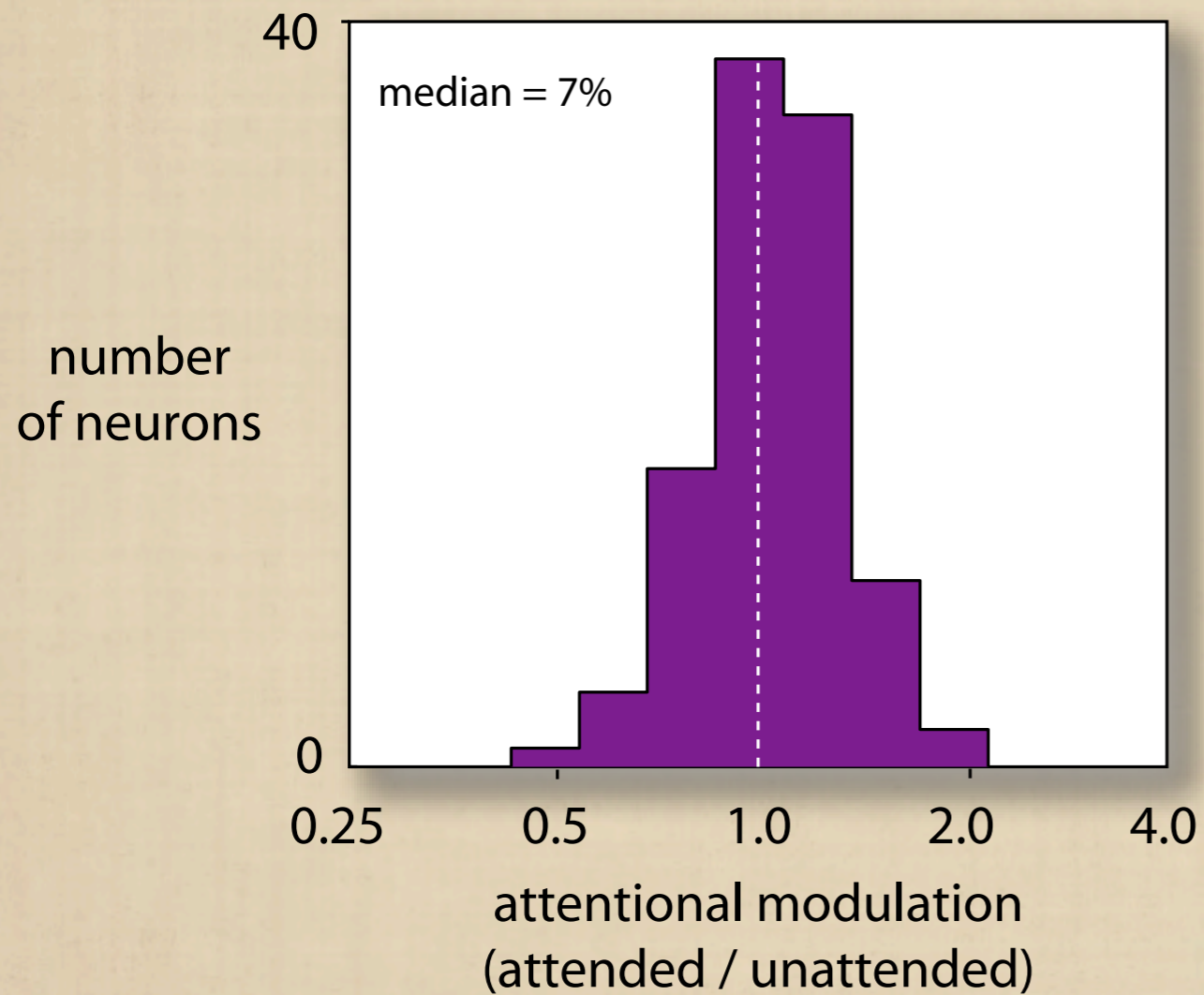

difficult mode

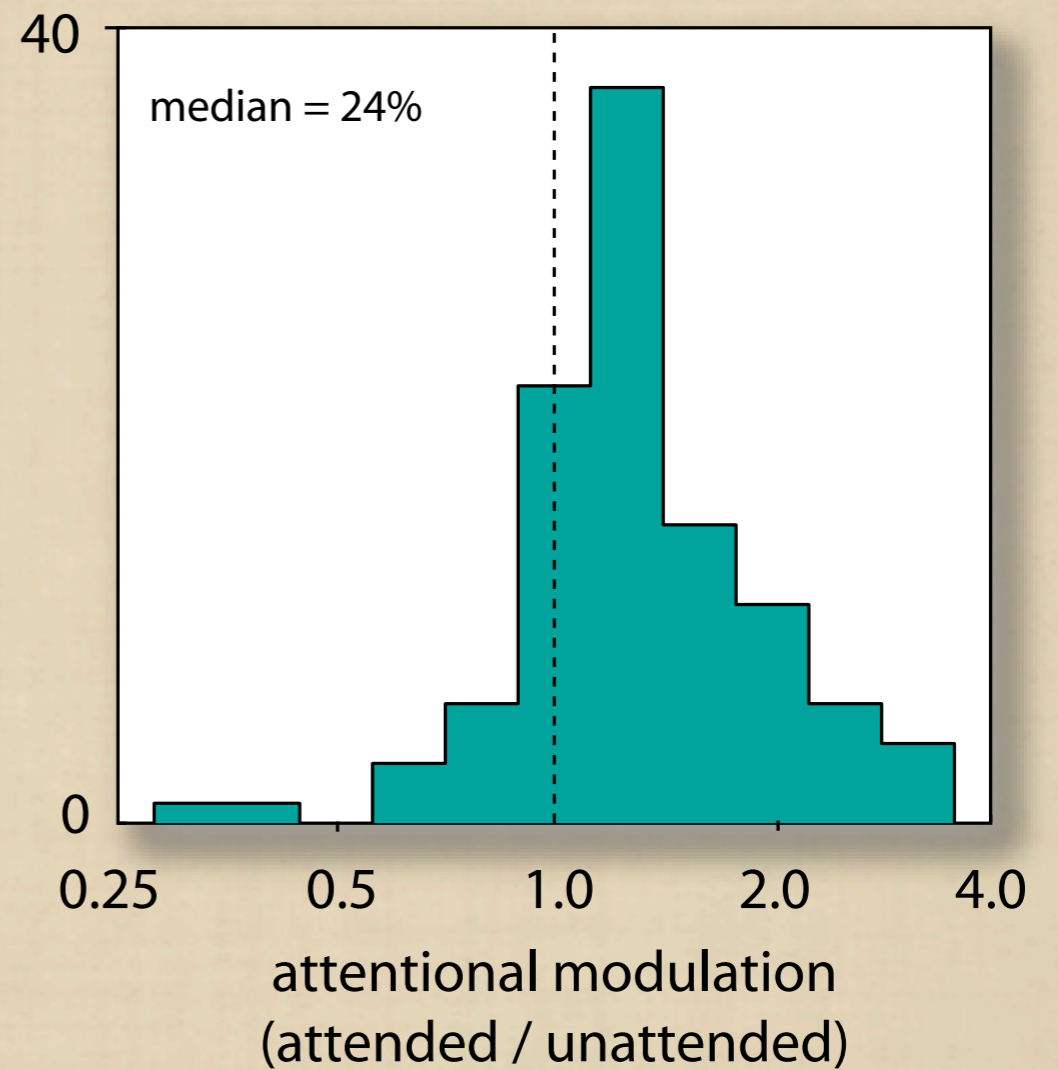

Motter (1994)

instruction
to shift
attention

Average
response
(spikes/s)

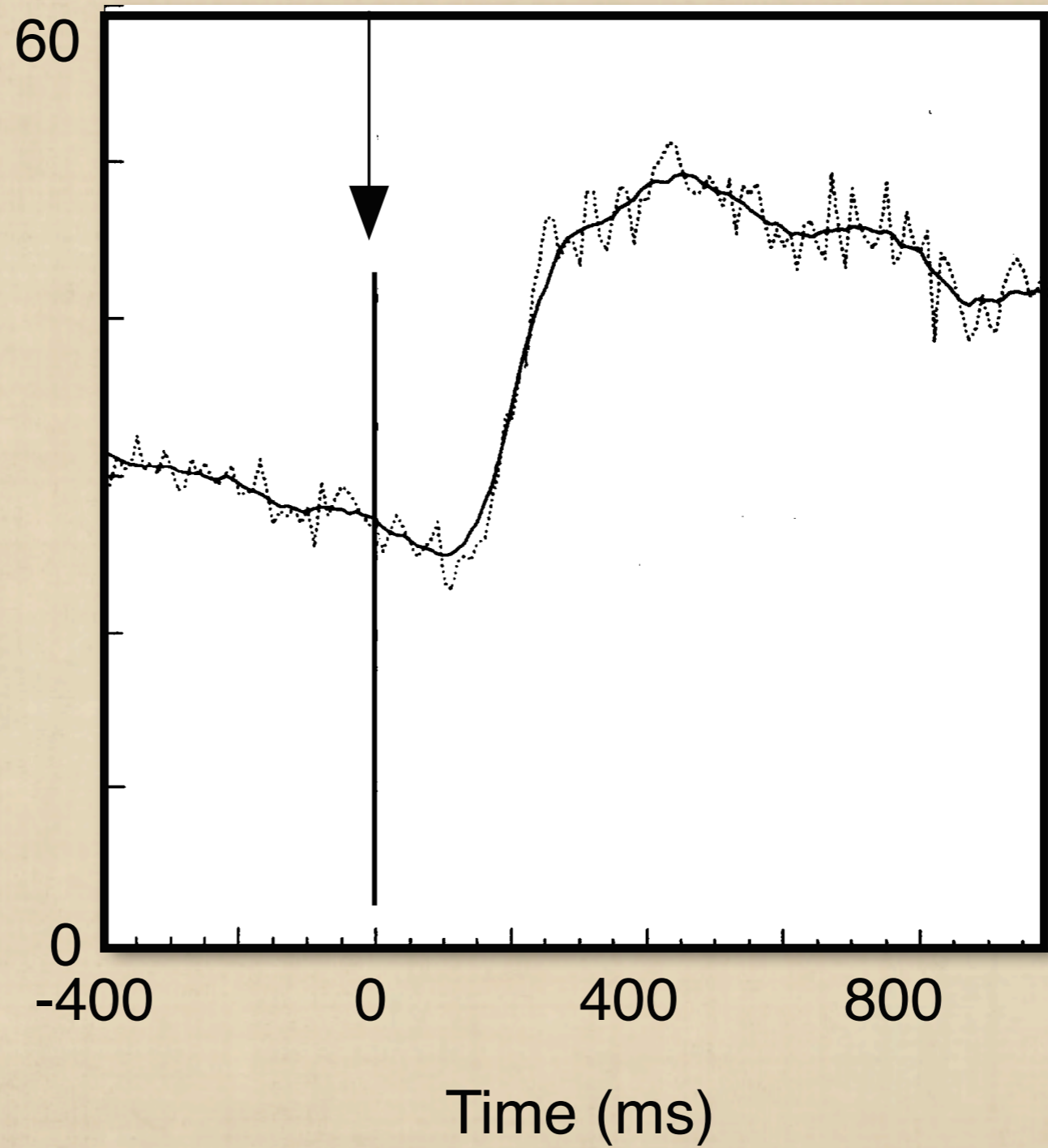

Average attention modulation of single unit responses at different cortical levels

Cook & Maunsell (2002)

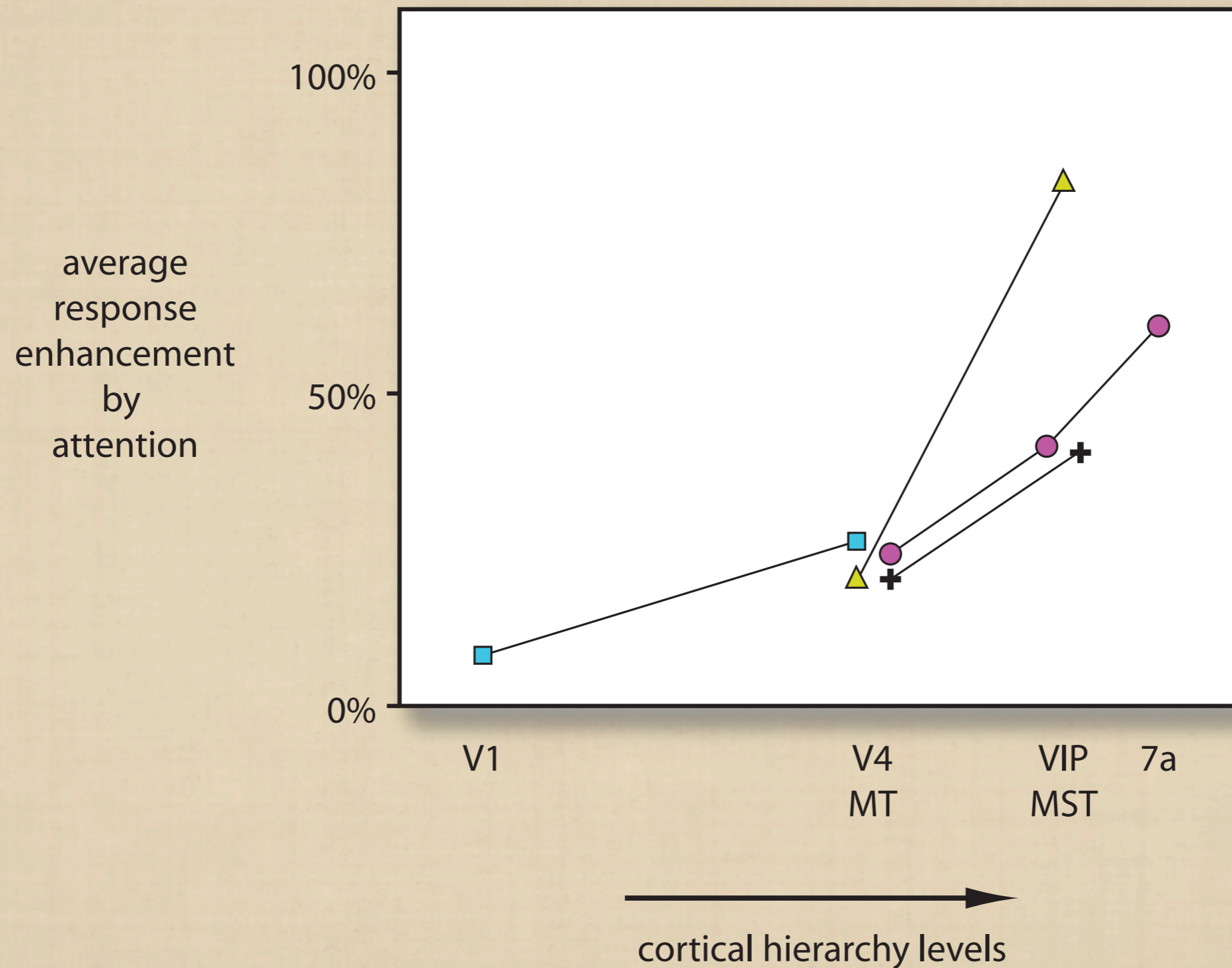

Size of modulation spatial attention of fMRI signal in different visual areas
O'Connor, Fukui, Pinsk, & Kastner (2002)

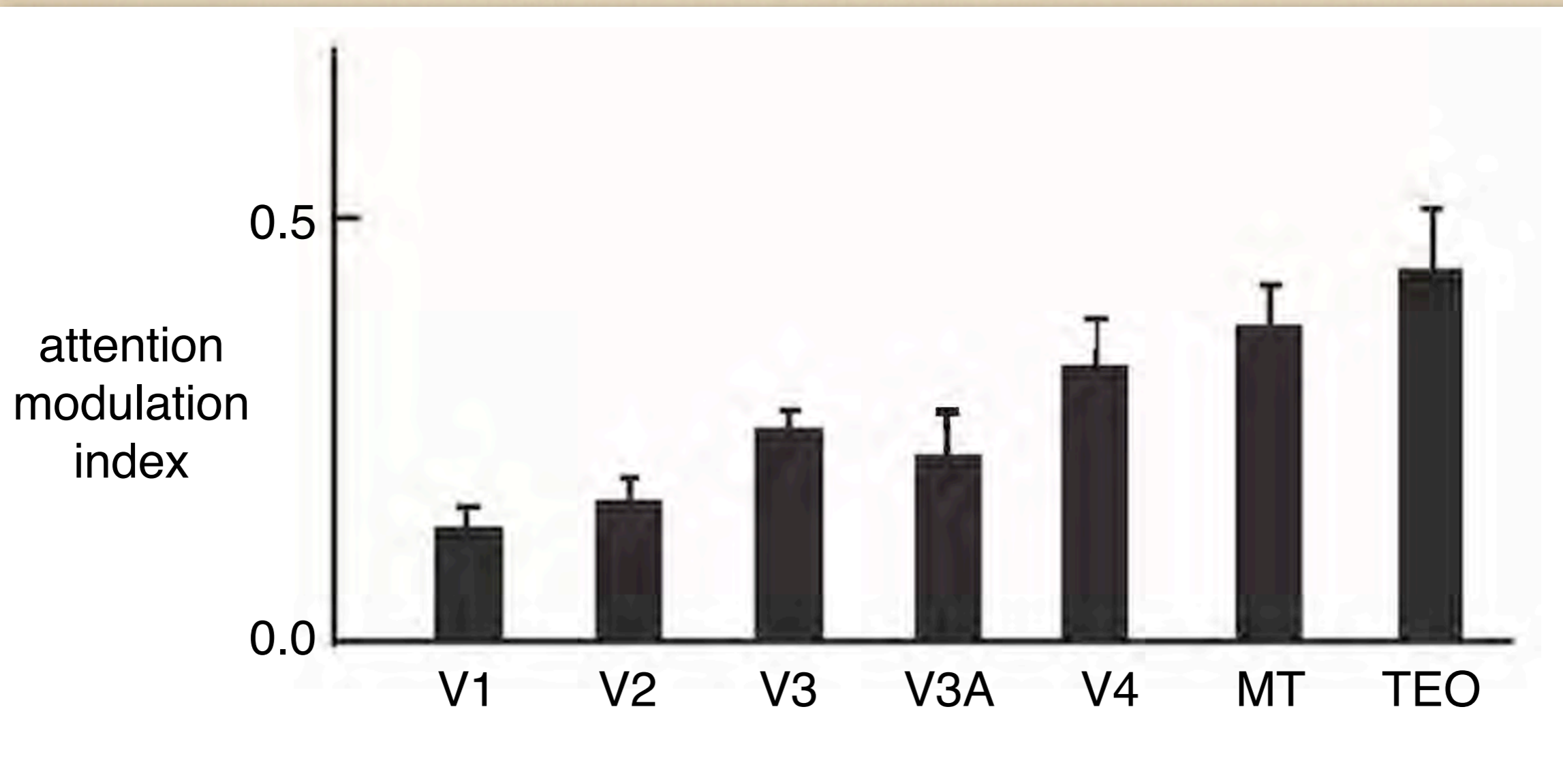

Size of modulation spatial attention of fMRI signal in different visual areas
O'Connor, Fukui, Pinsk, & Kastner (2002)

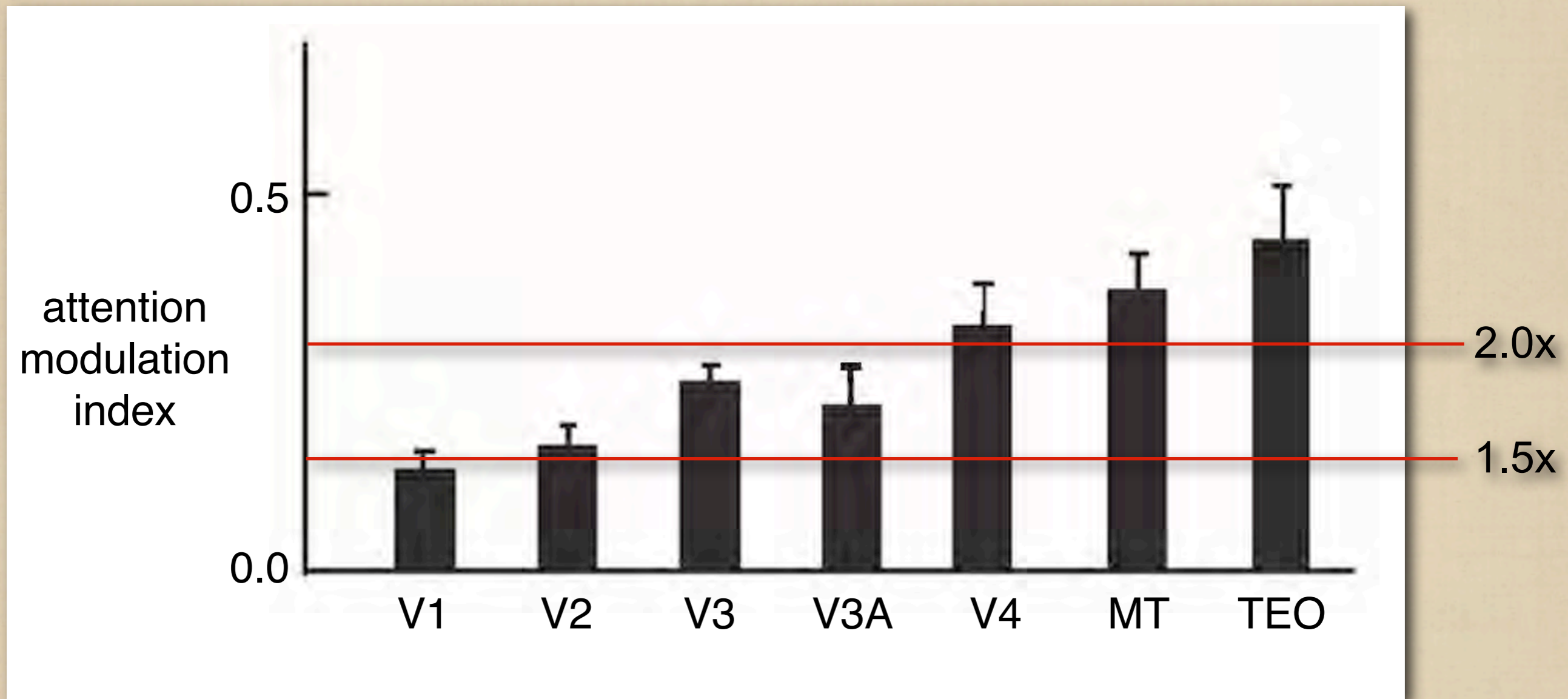

Modulation of V1 fMRI BOLD signal by attention

Somers et al. 1999

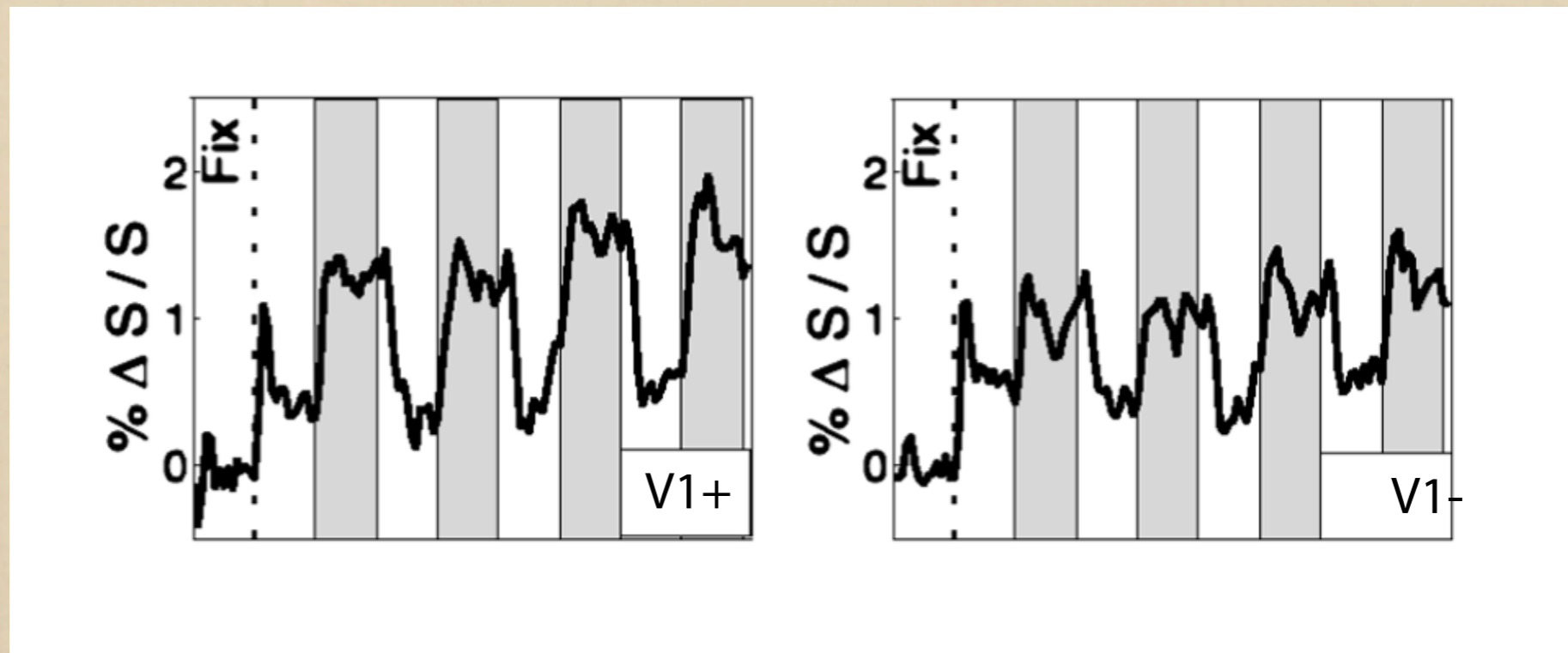
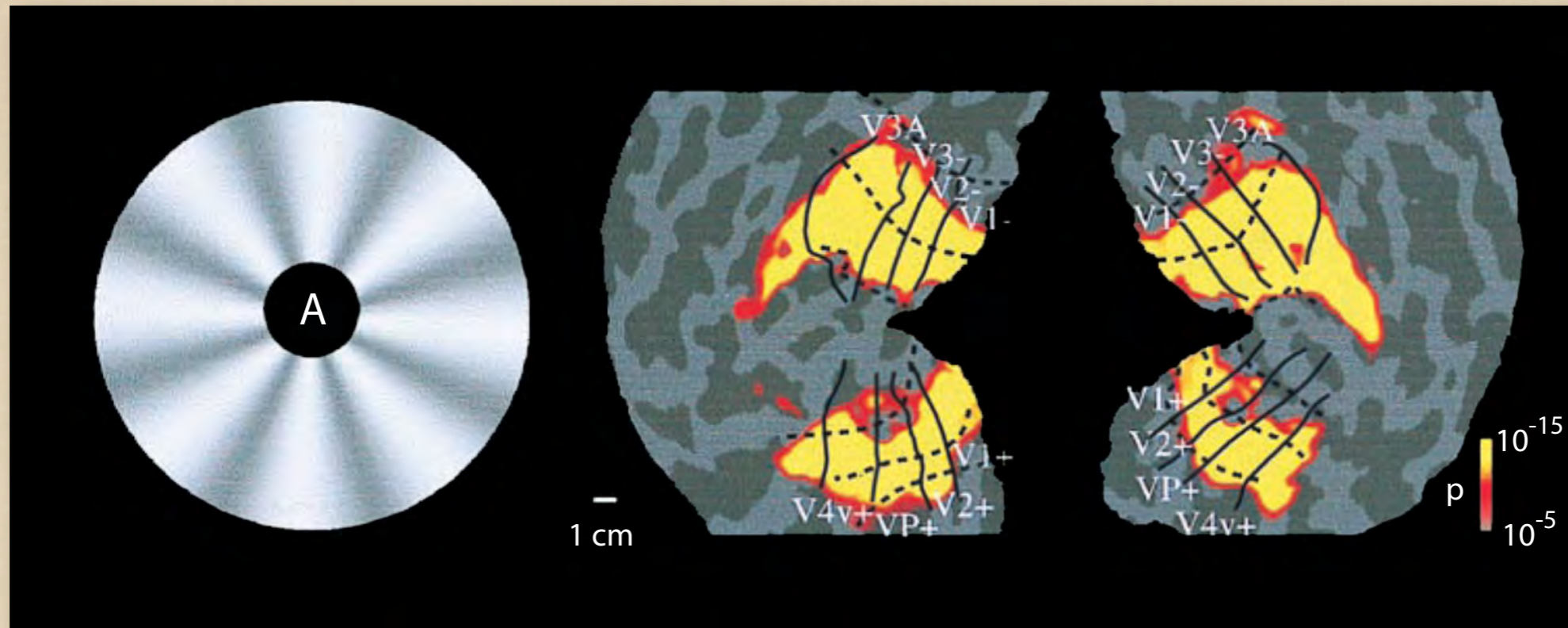

Recording from human visual cortex

Yoshor et al. 2007

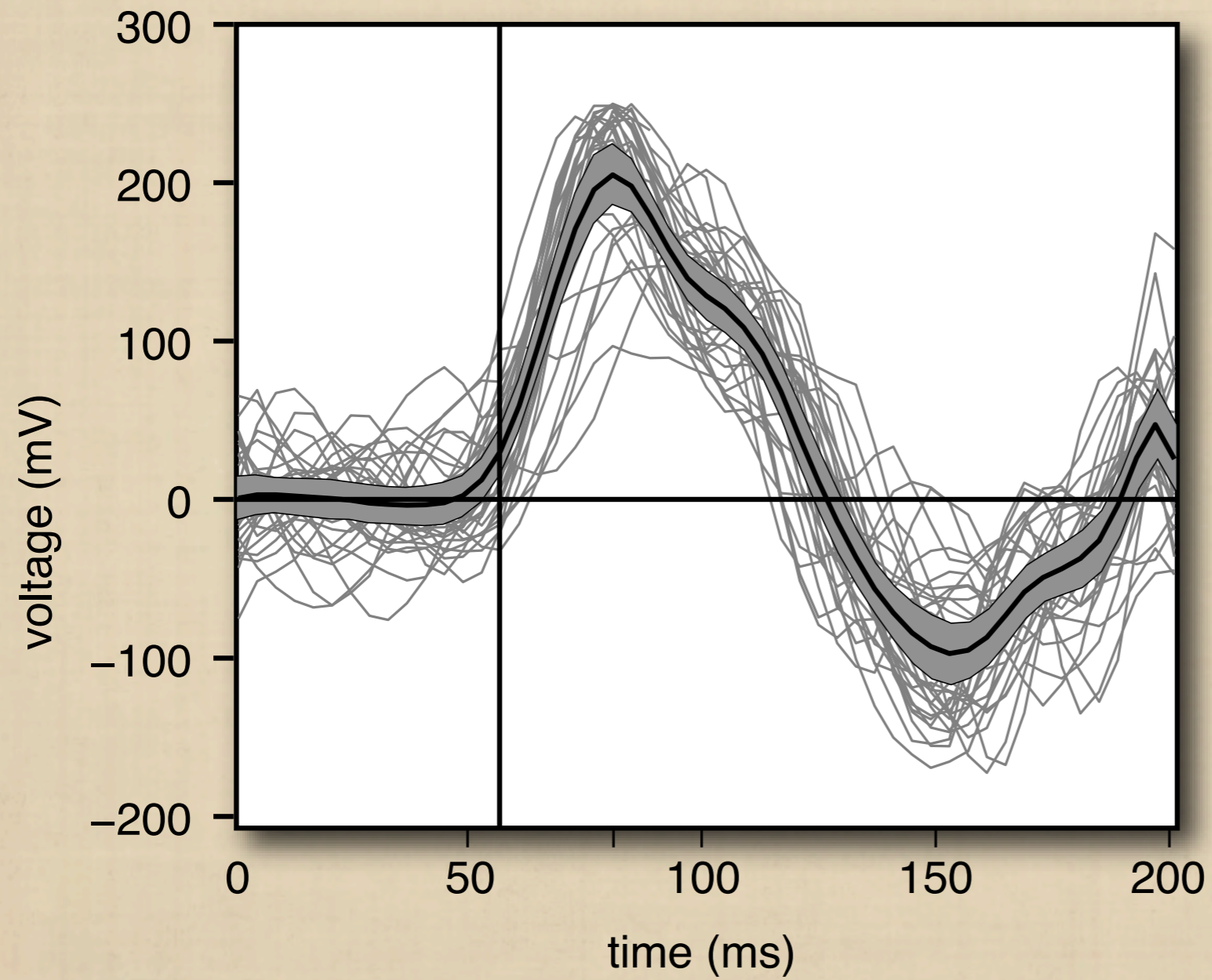

Responsive and unresponsive locations

Yoshor et al. 2007

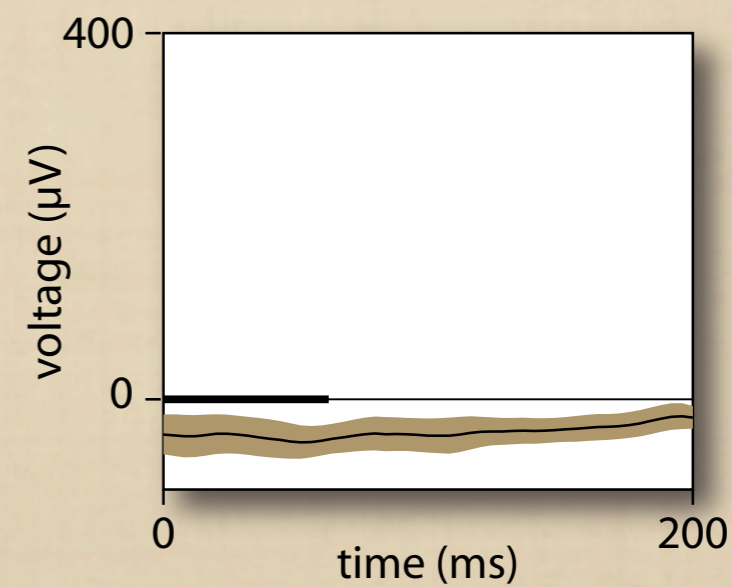
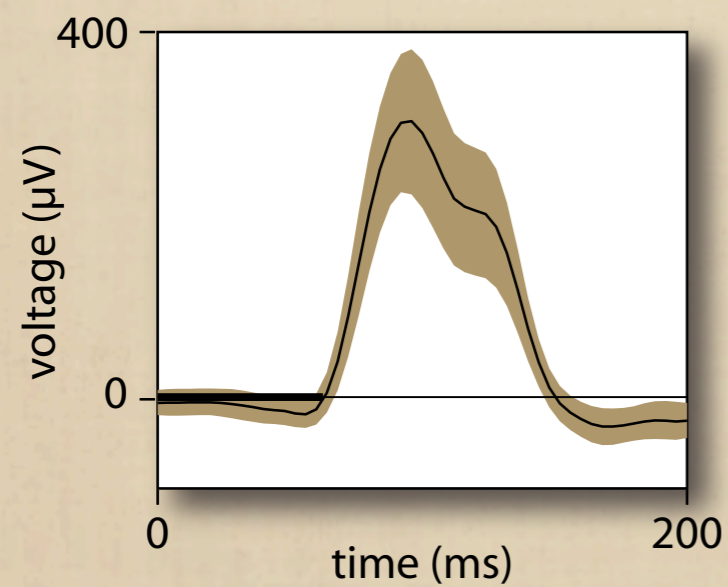
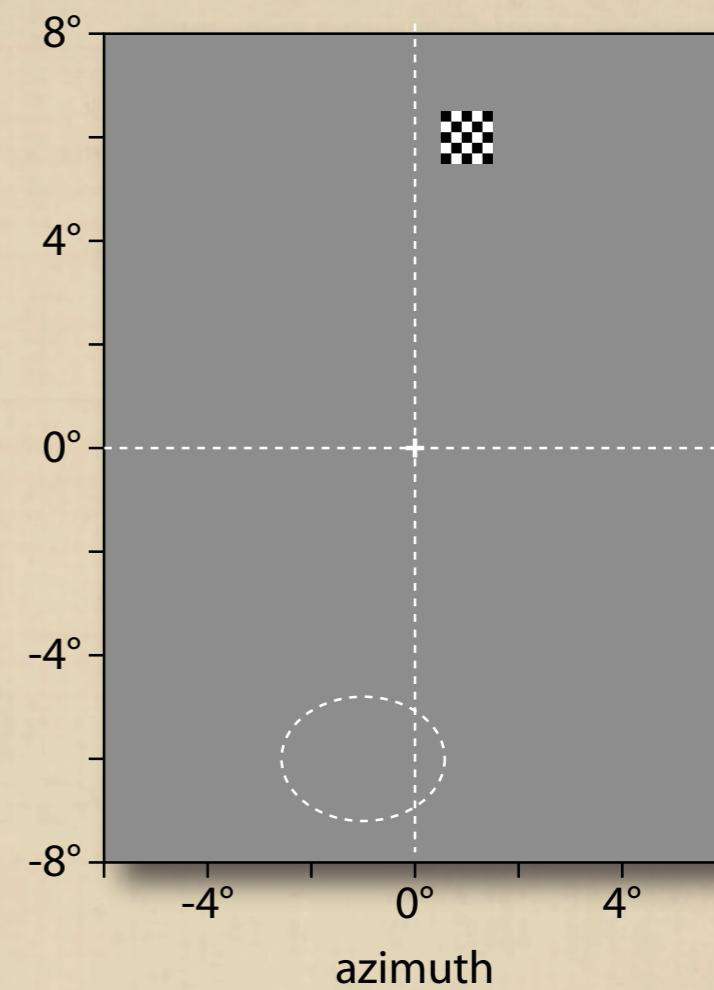
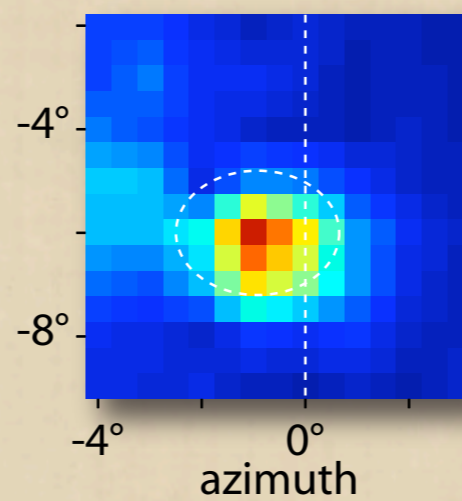
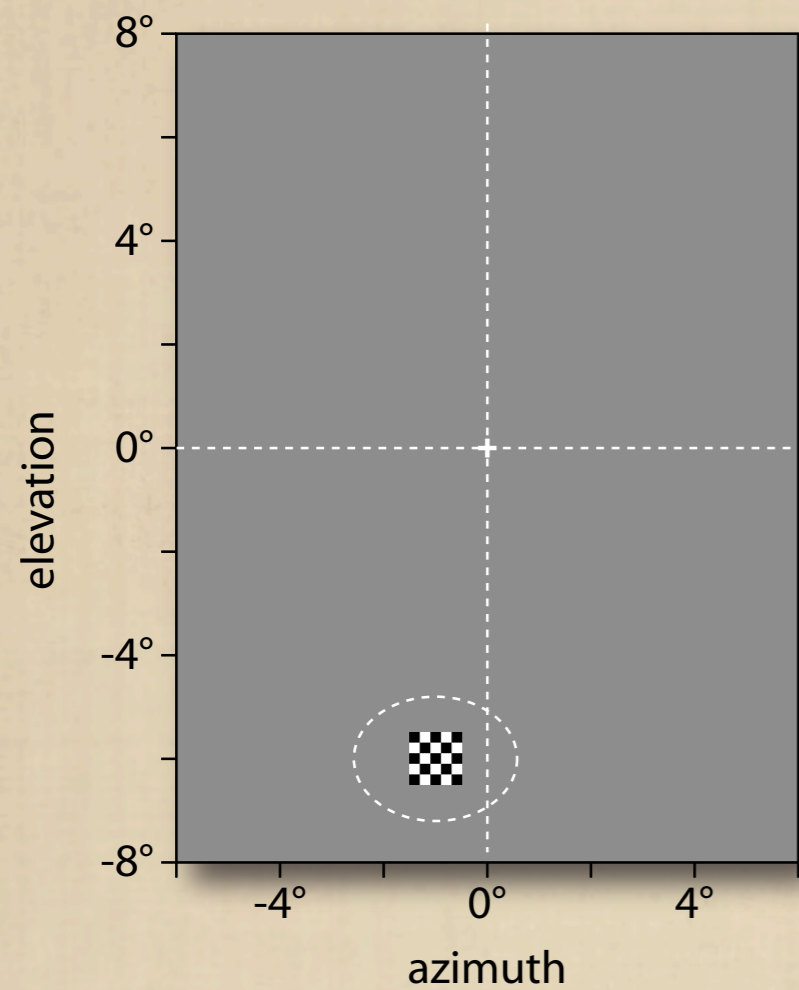

Spatial attention task

Yoshor et al. 2007

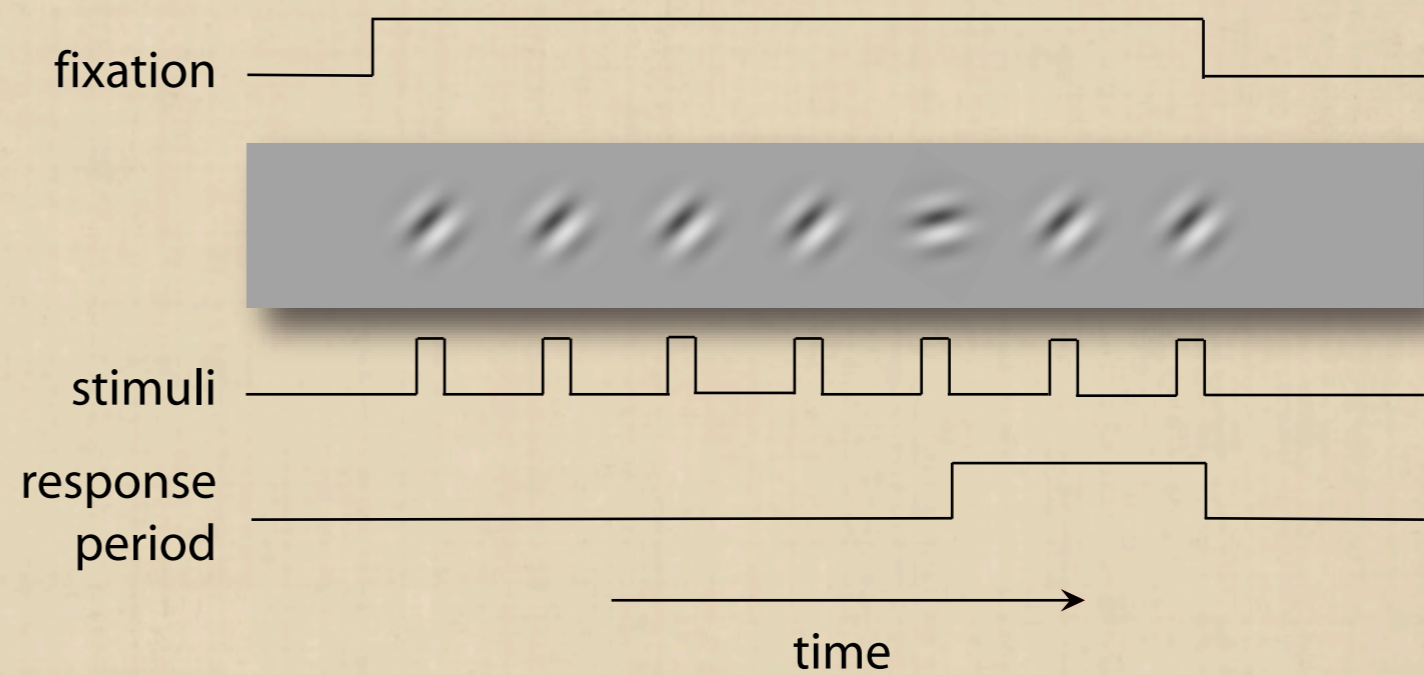
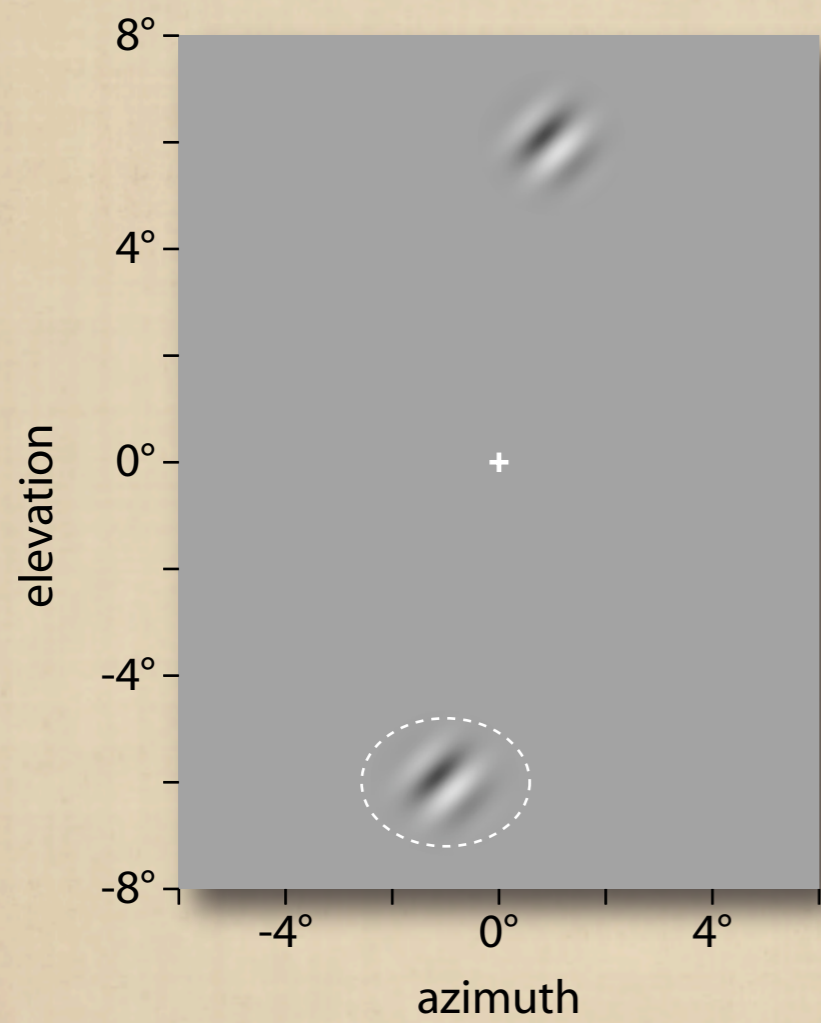

Effect of attention on human LFP

Yoshor et al. 2007

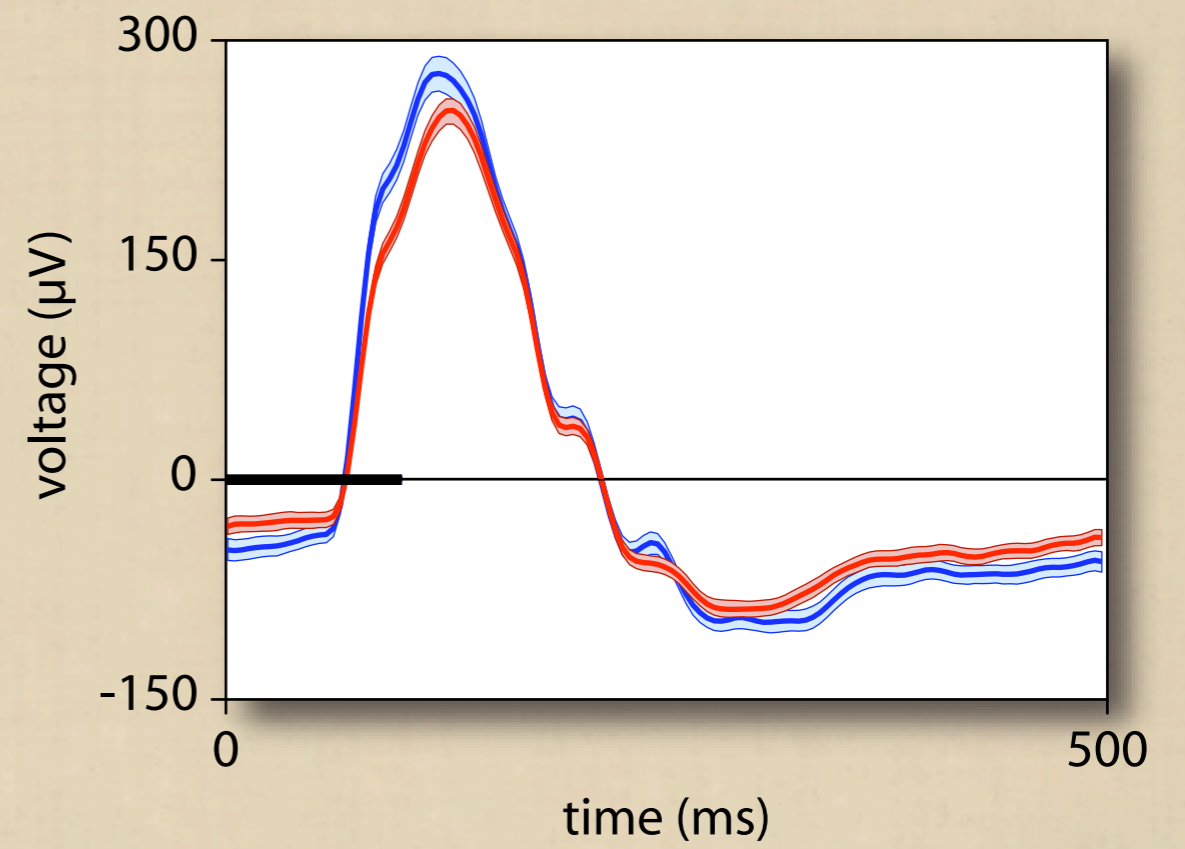
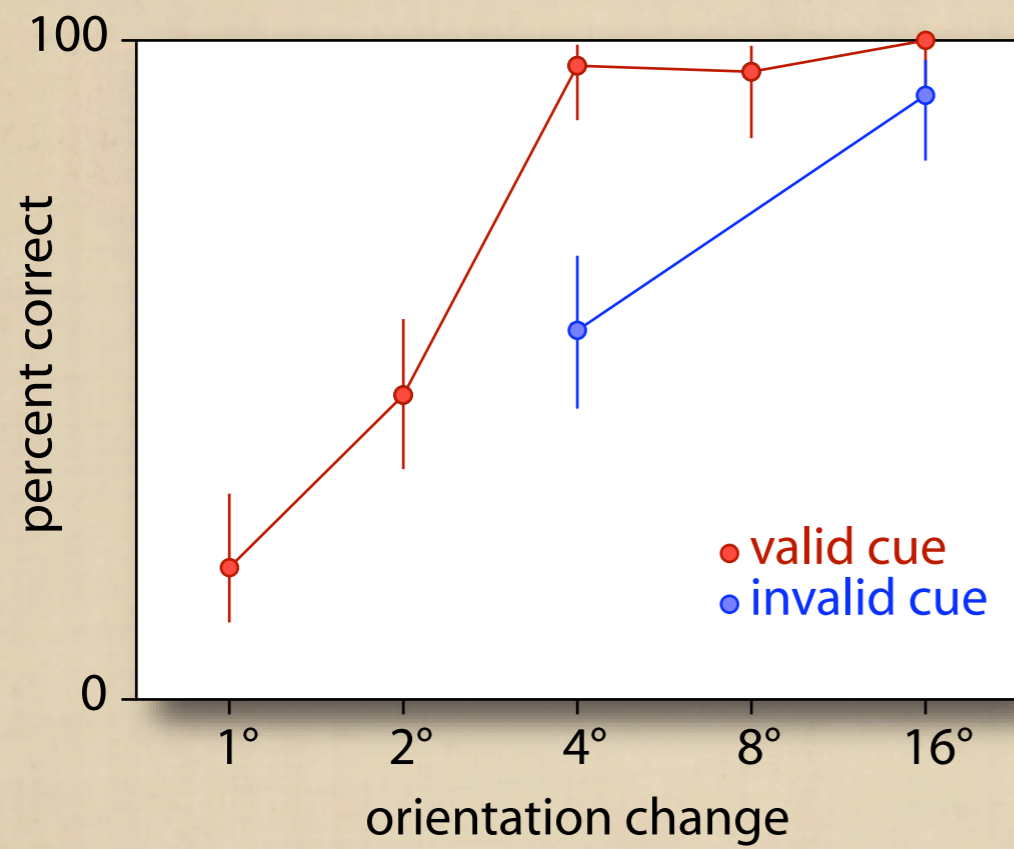

response

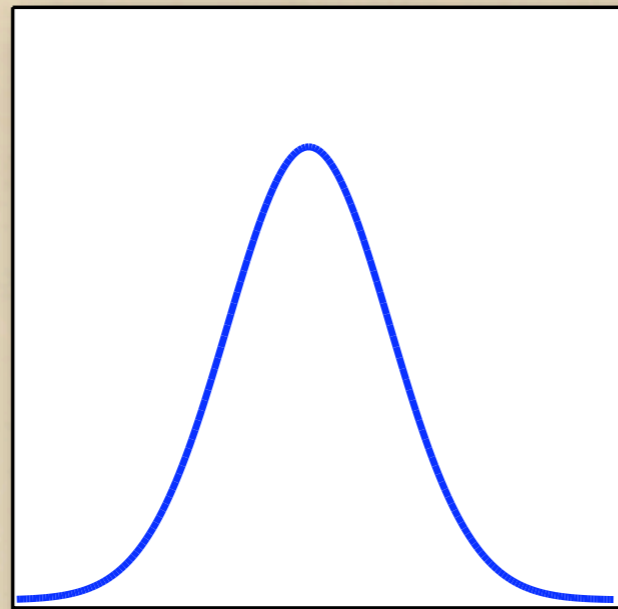

orientation

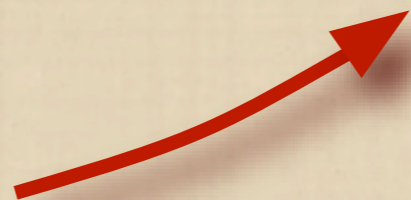

stronger response

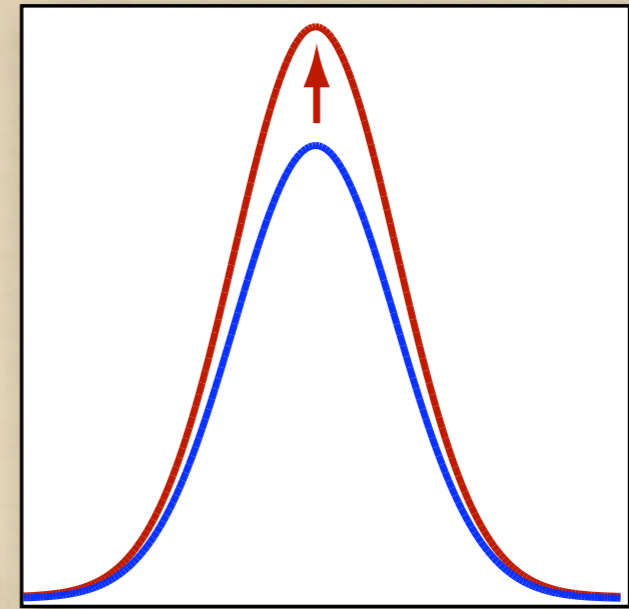

stronger response & increased selectivity

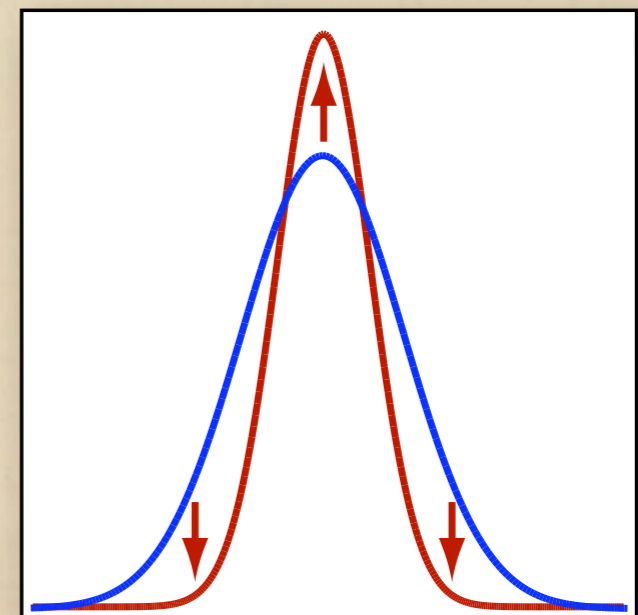

Change in average V4 orientation tuning by attention

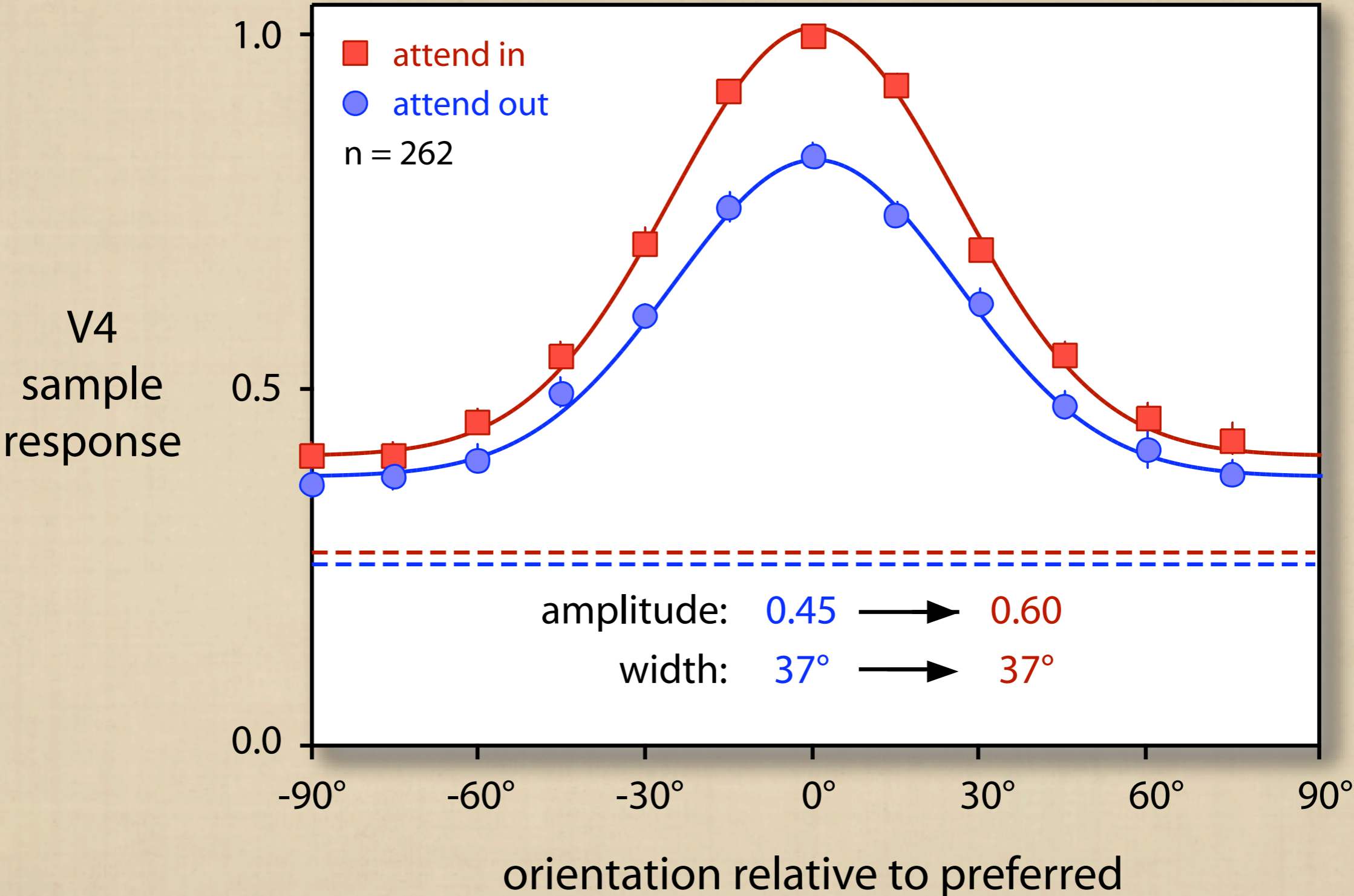

Attention does not sharpen direction tuning in MT

Treue & Martinez-Trujillo 1999

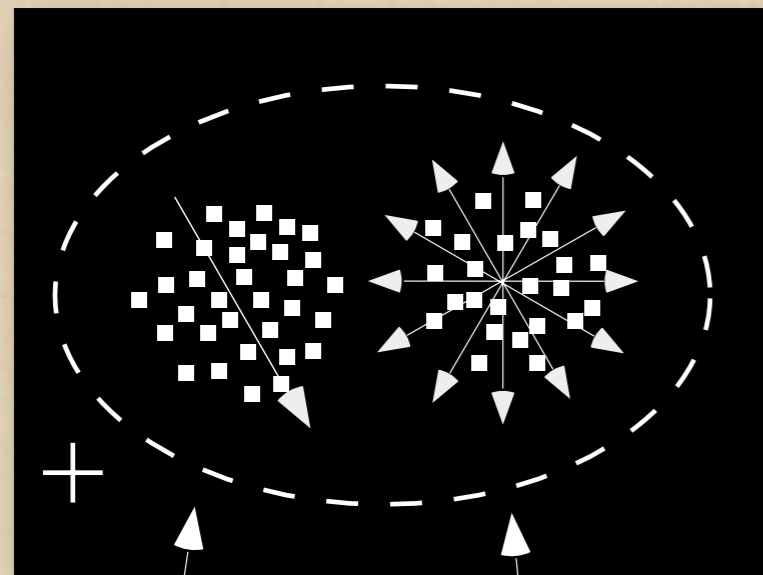

pattern A

pattern B

response
(spikes/s)

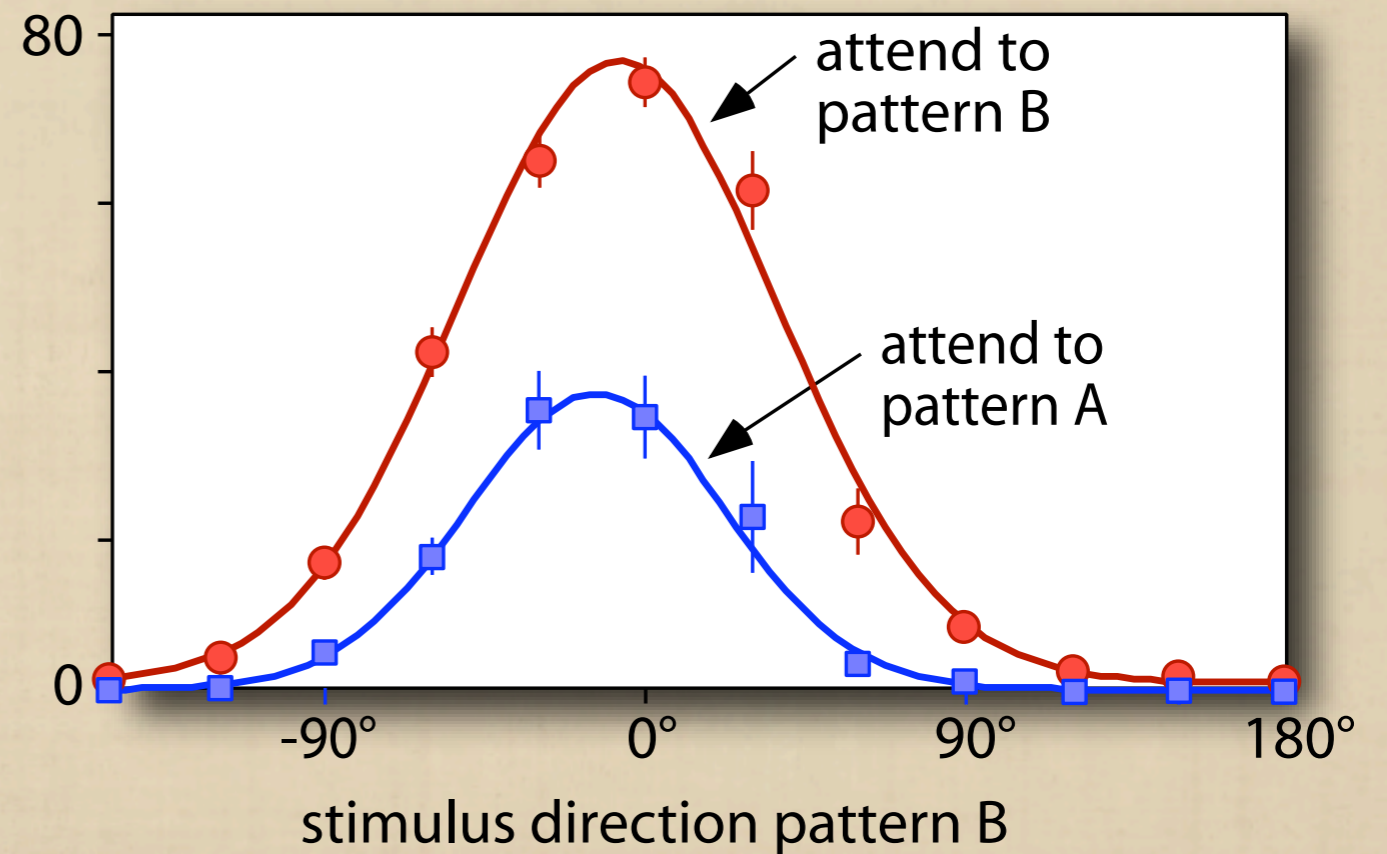

Average MT contrast response functions

(n = 56)

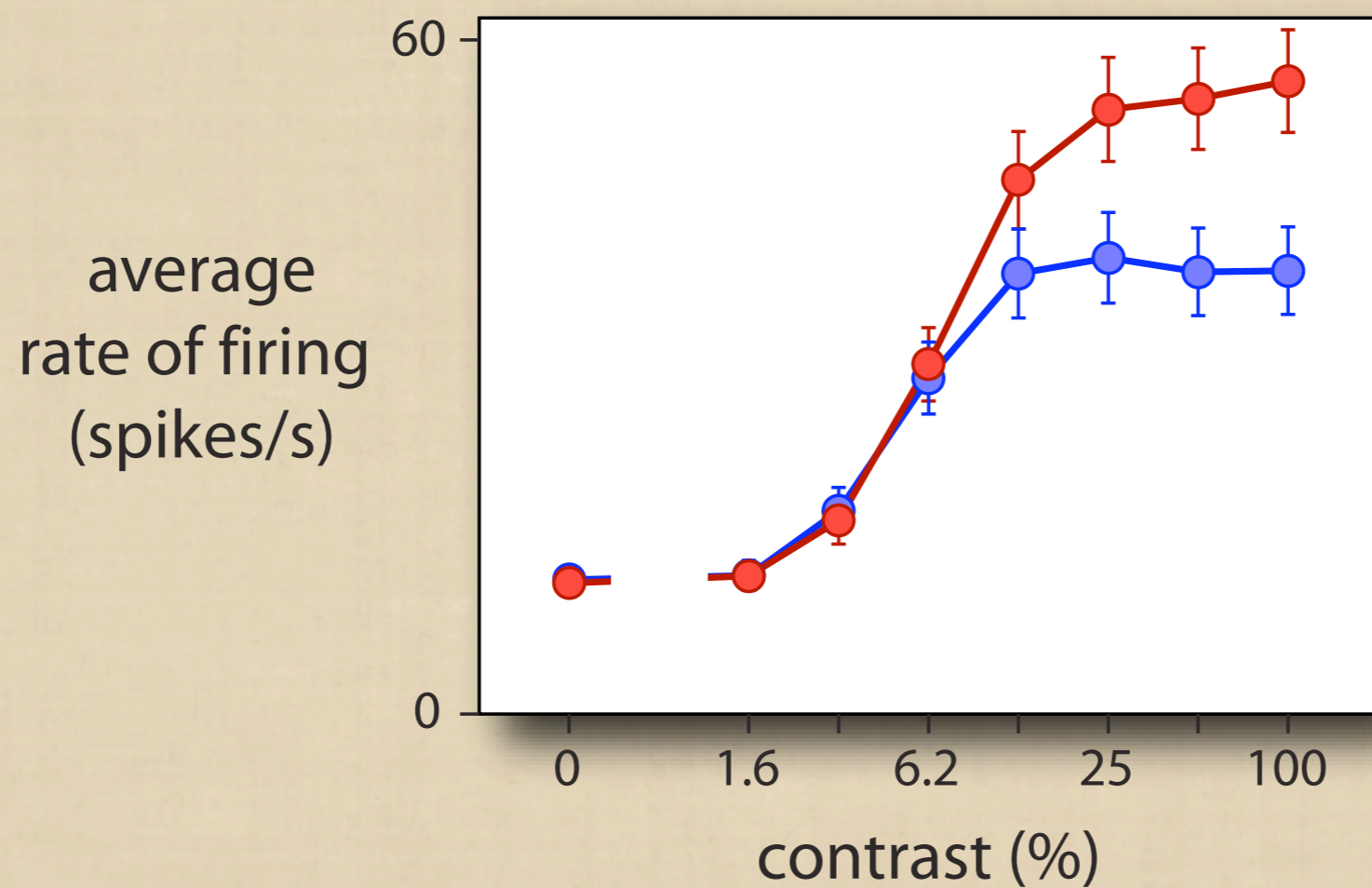

Attention does not sharpen direction tuning in MT

Treue & Martinez-Trujillo 1999

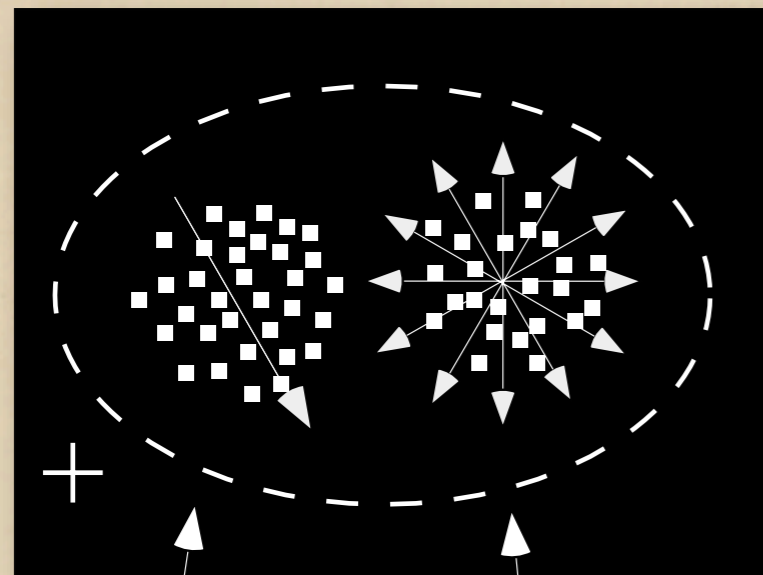

pattern A

pattern B

response
(spikes/s)

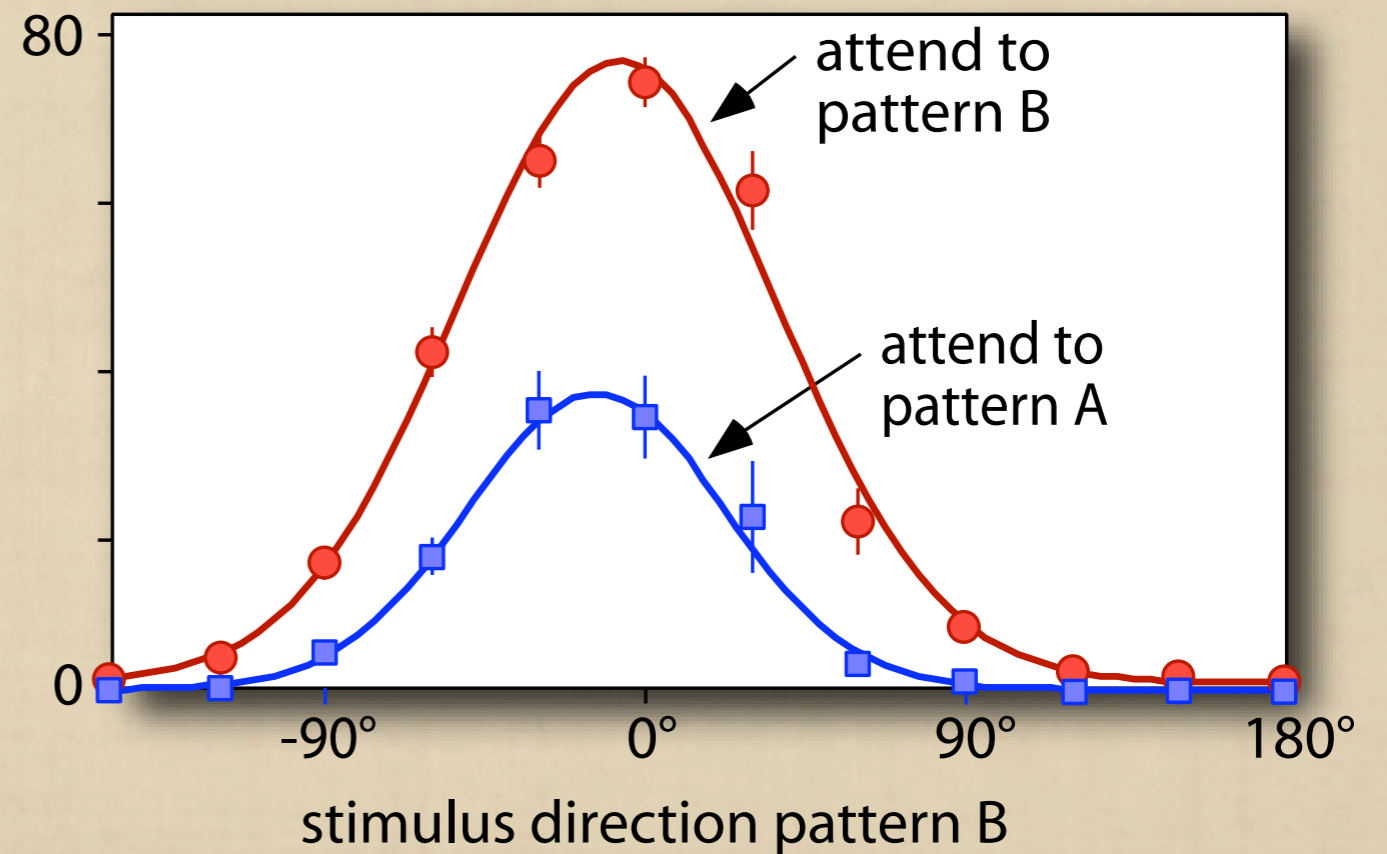

Attention can sharpen the tuning of a population response

Martinez-Trujillo & Treue 2004

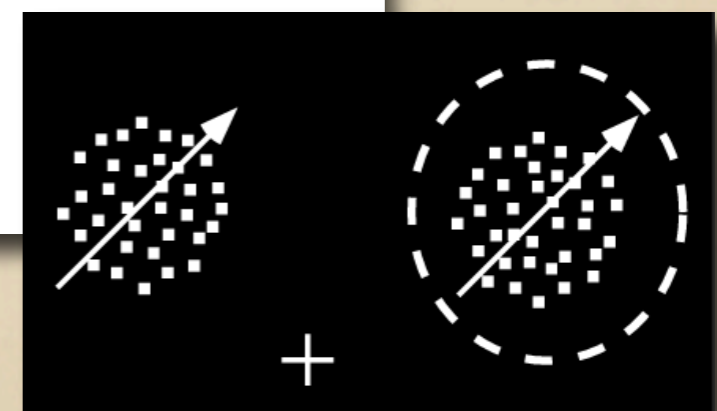
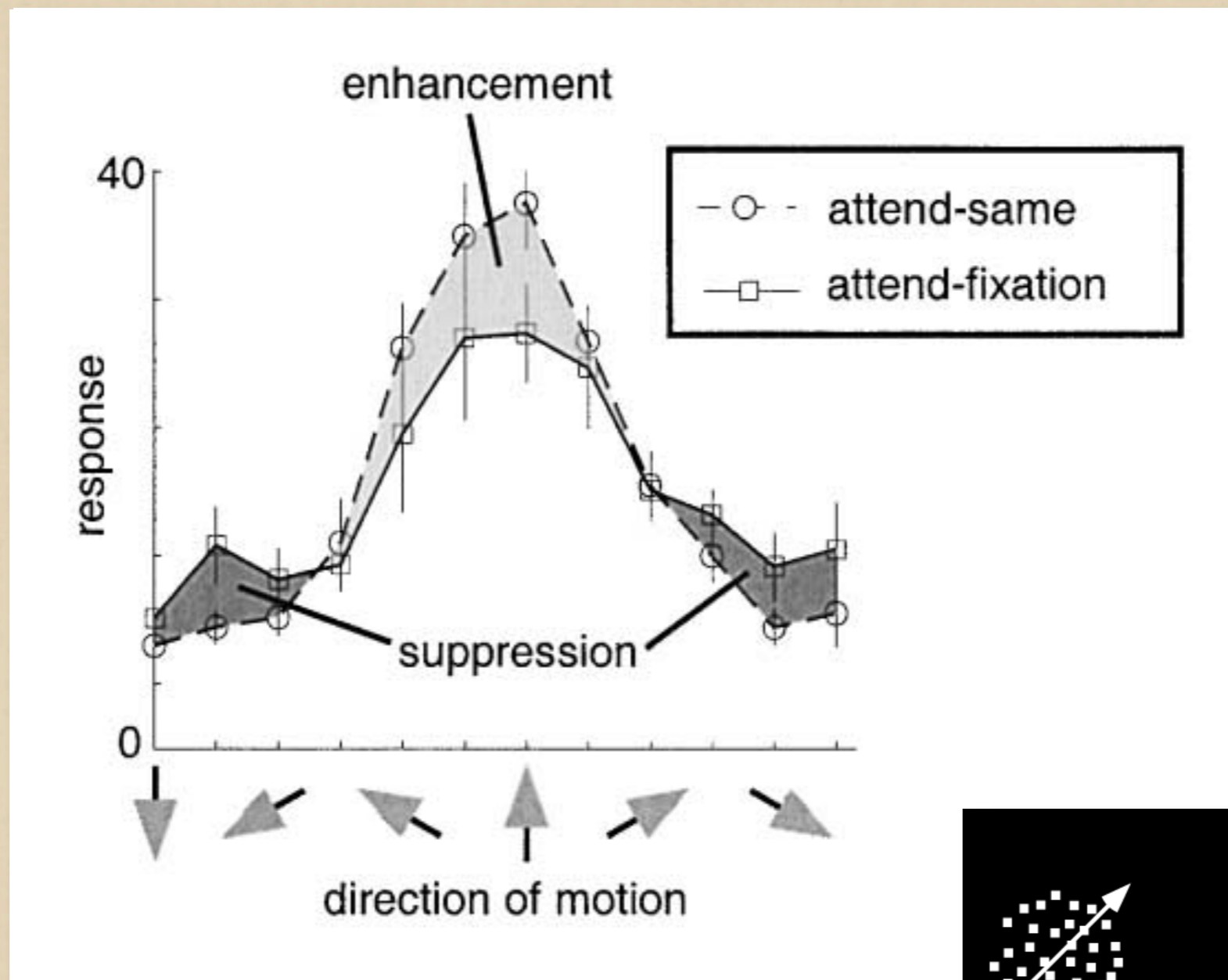

Orientation tuning measured with different contrasts

Cat V1

Sclar & Freeman 1982

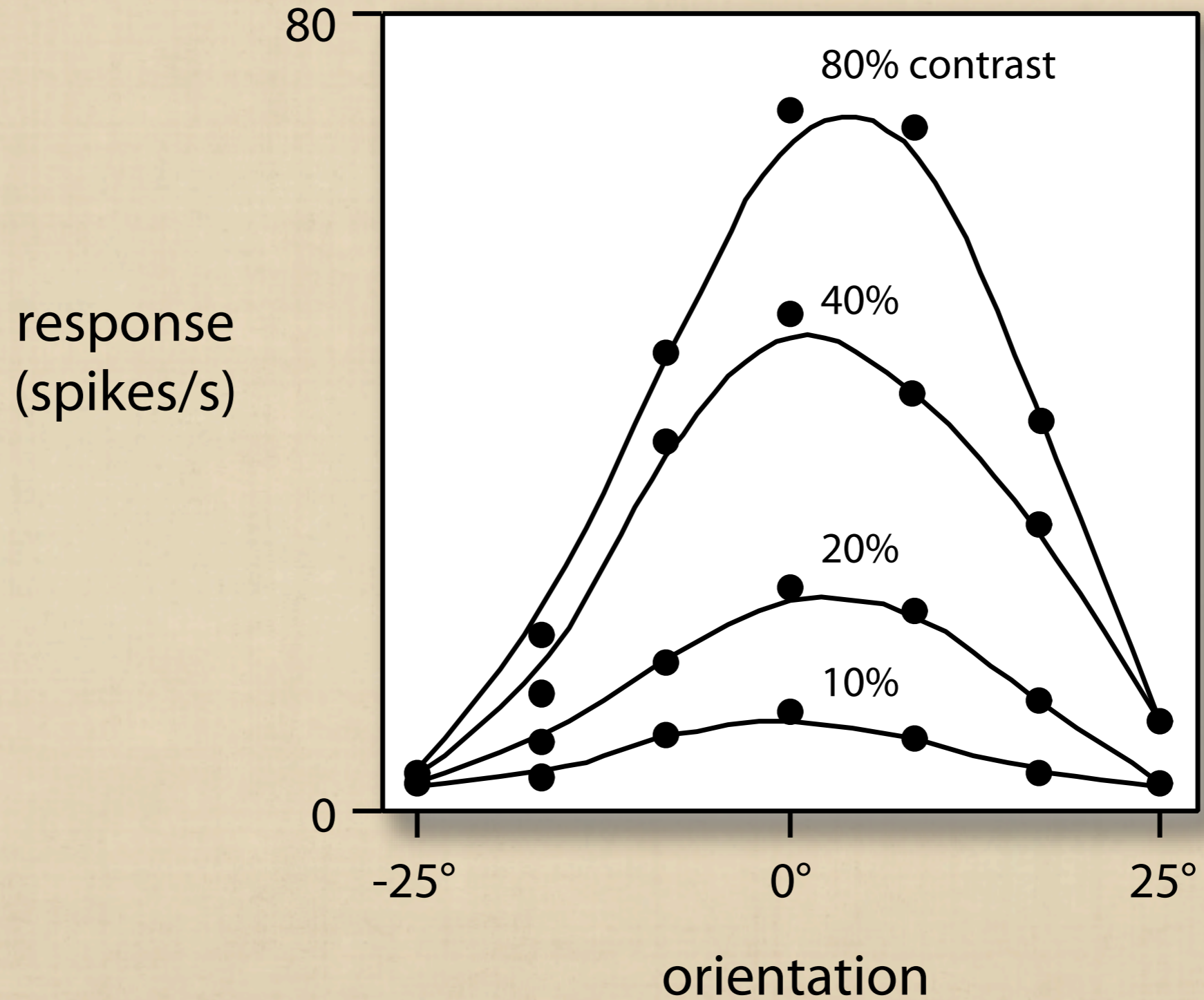

Change in average V4 orientation tuning by attention

McAdams & Maunsell (1999)

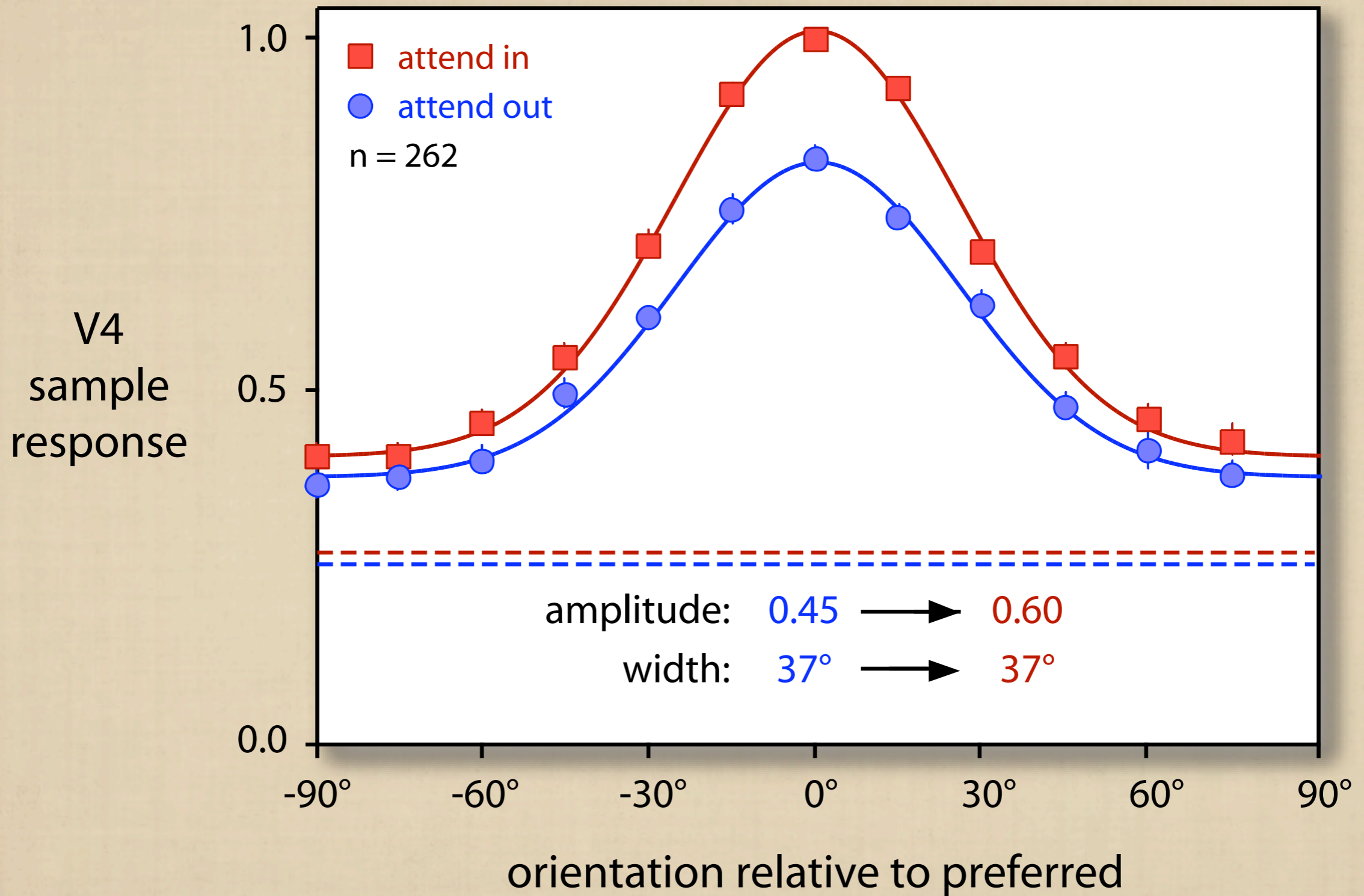

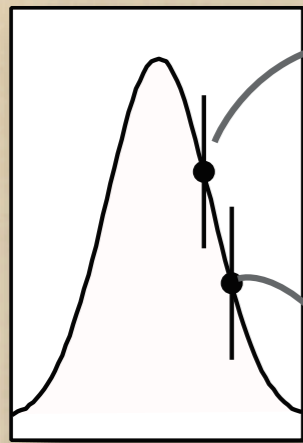

orientation

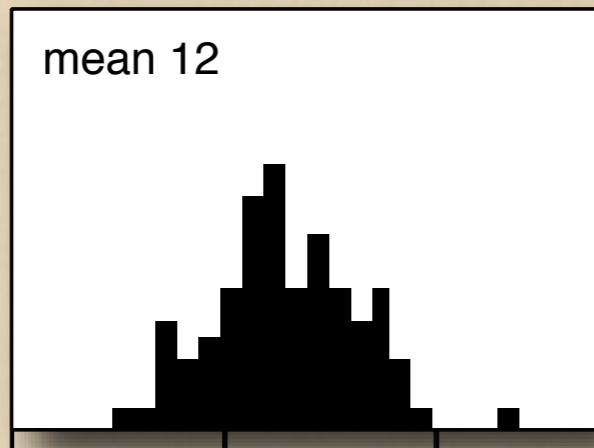

mean 12

0 10 20

spikes per stimulus

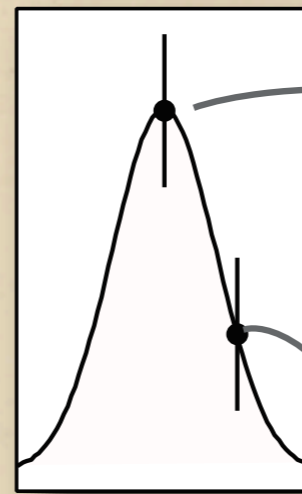

orientation

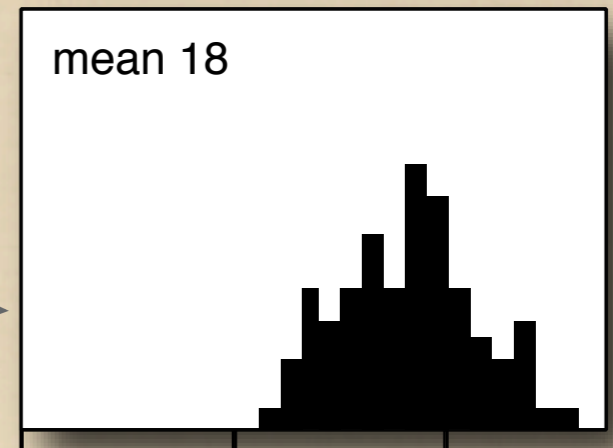

mean 18

0 10 20

spikes per stimulus

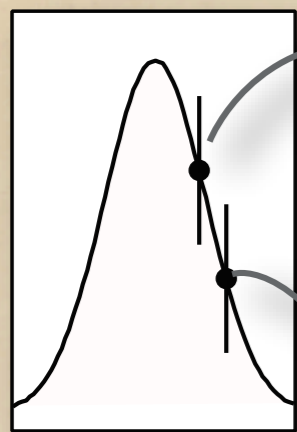

Orientation

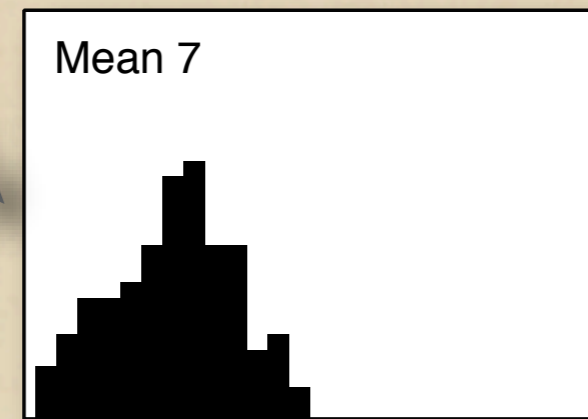
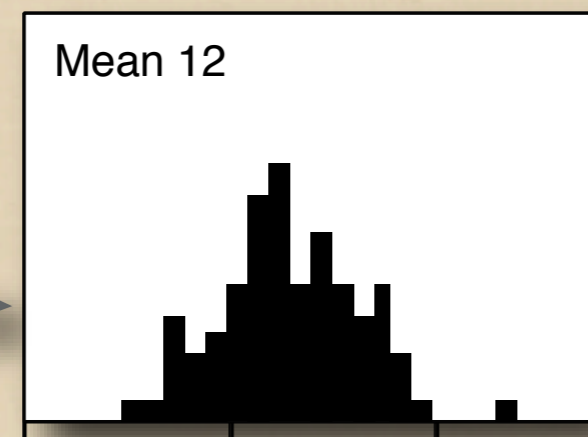

0 10 20
Spikes Per Stimulus

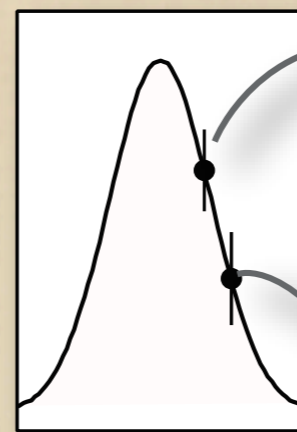

Orientation

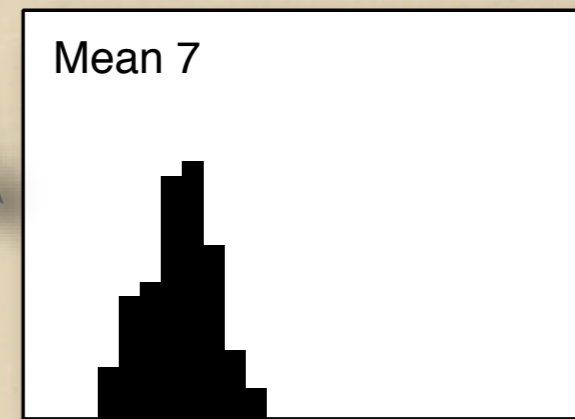
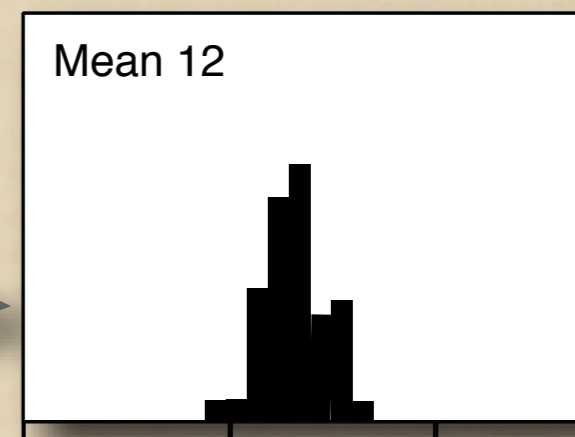

0 10 20
Spikes Per Stimulus

Variance of cat V1 neuron response

Dean 1981

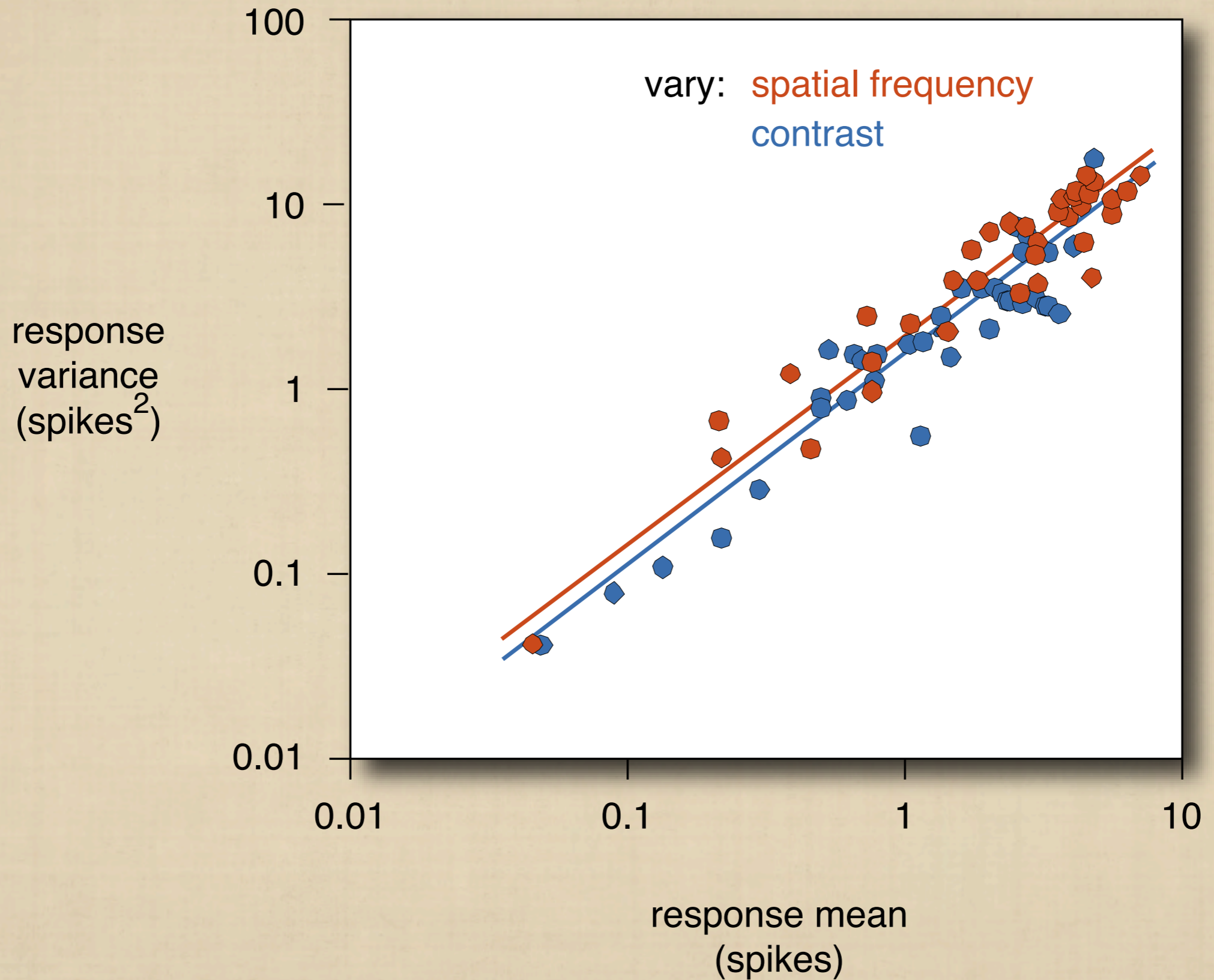

V4 sample counts-variance functions

McAdams & Maunsell (1999)

with attention

$$\text{variance} = 1.2 * \text{counts}^{1.1}$$

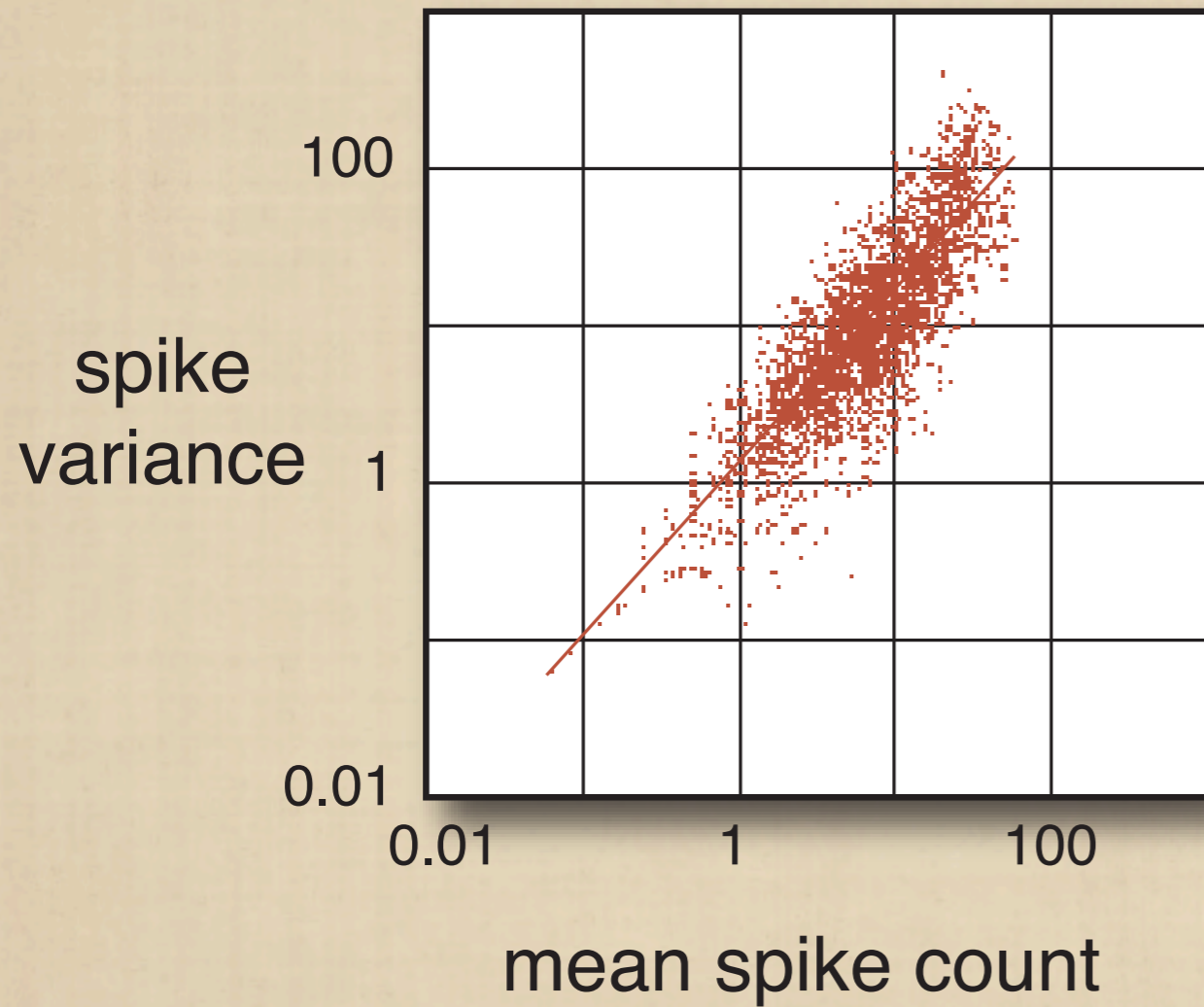

without attention

$$\text{variance} = 1.3 * \text{counts}^{1.1}$$

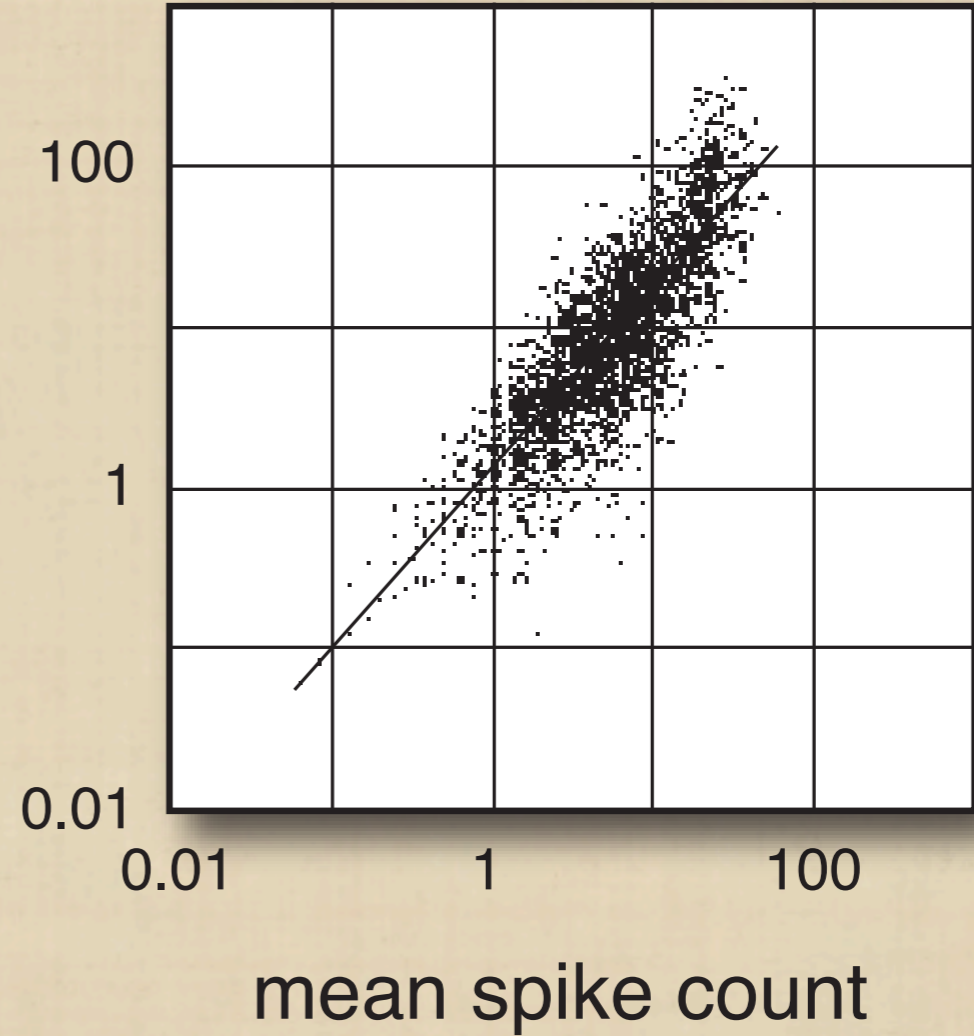

response

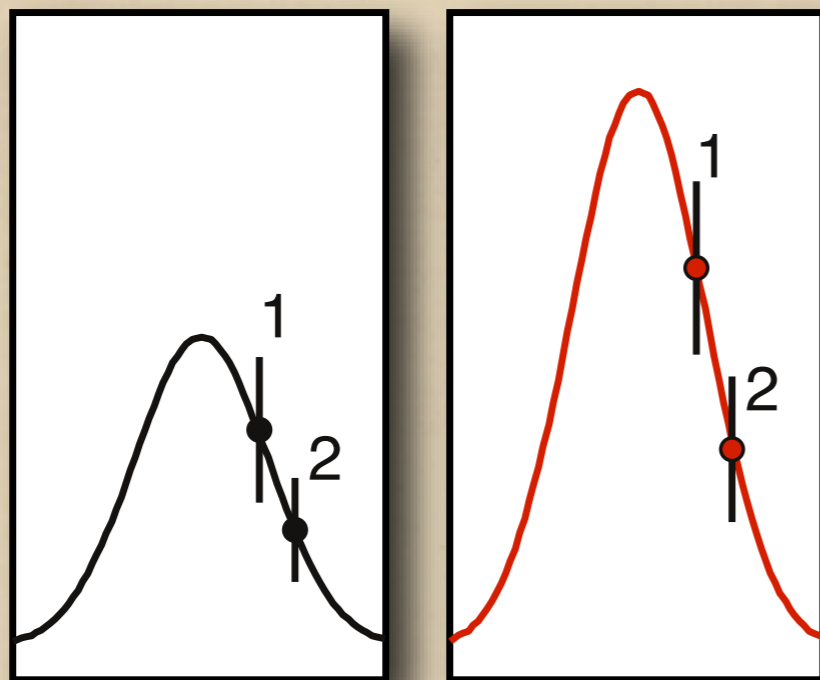

orientation

orientation

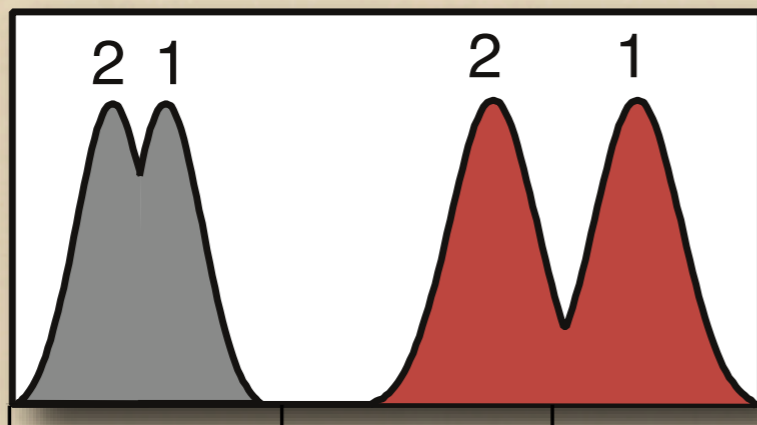

spikes per stimulus

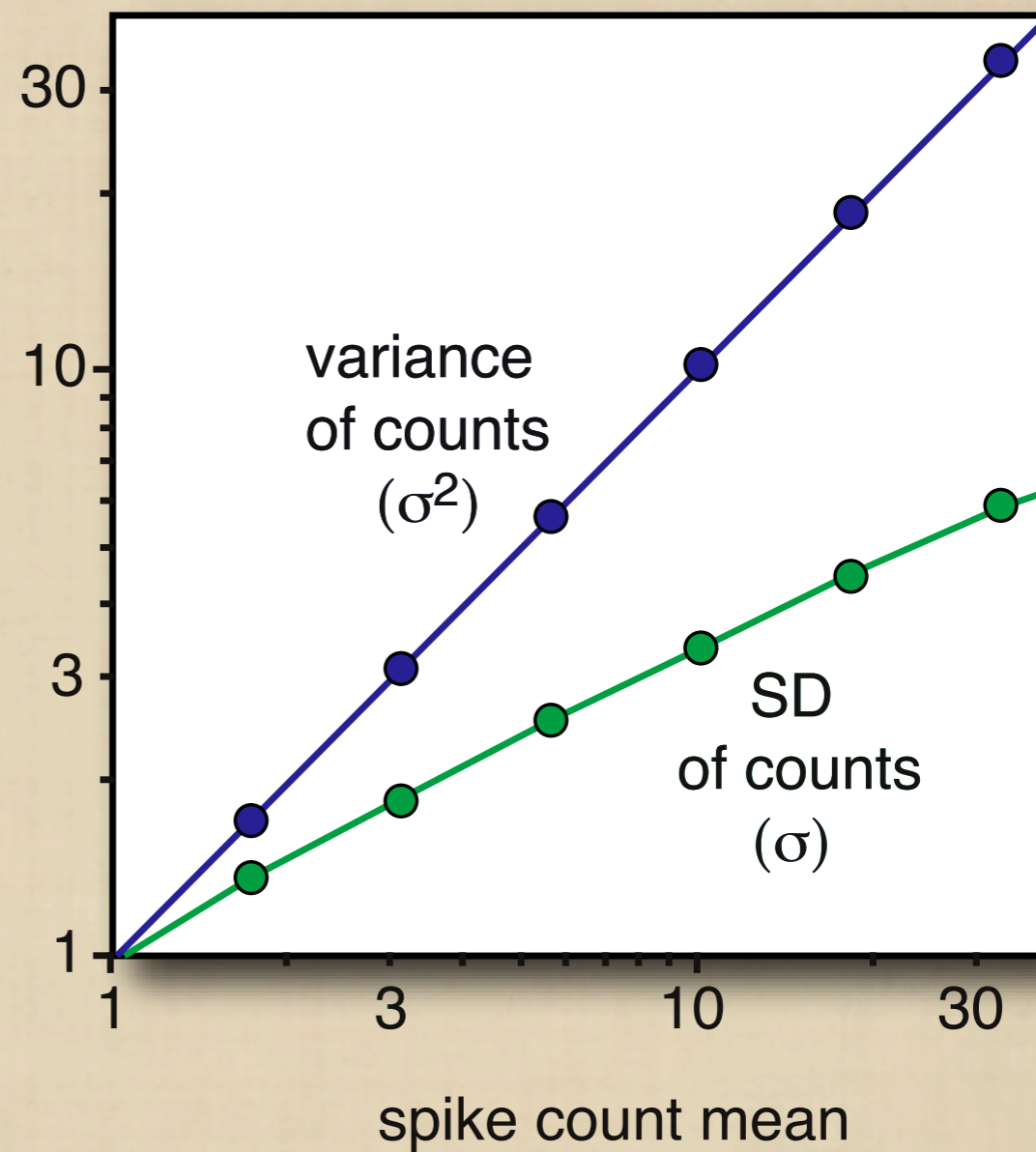

Effect of attention on orientation discriminability



discriminability
attending to target

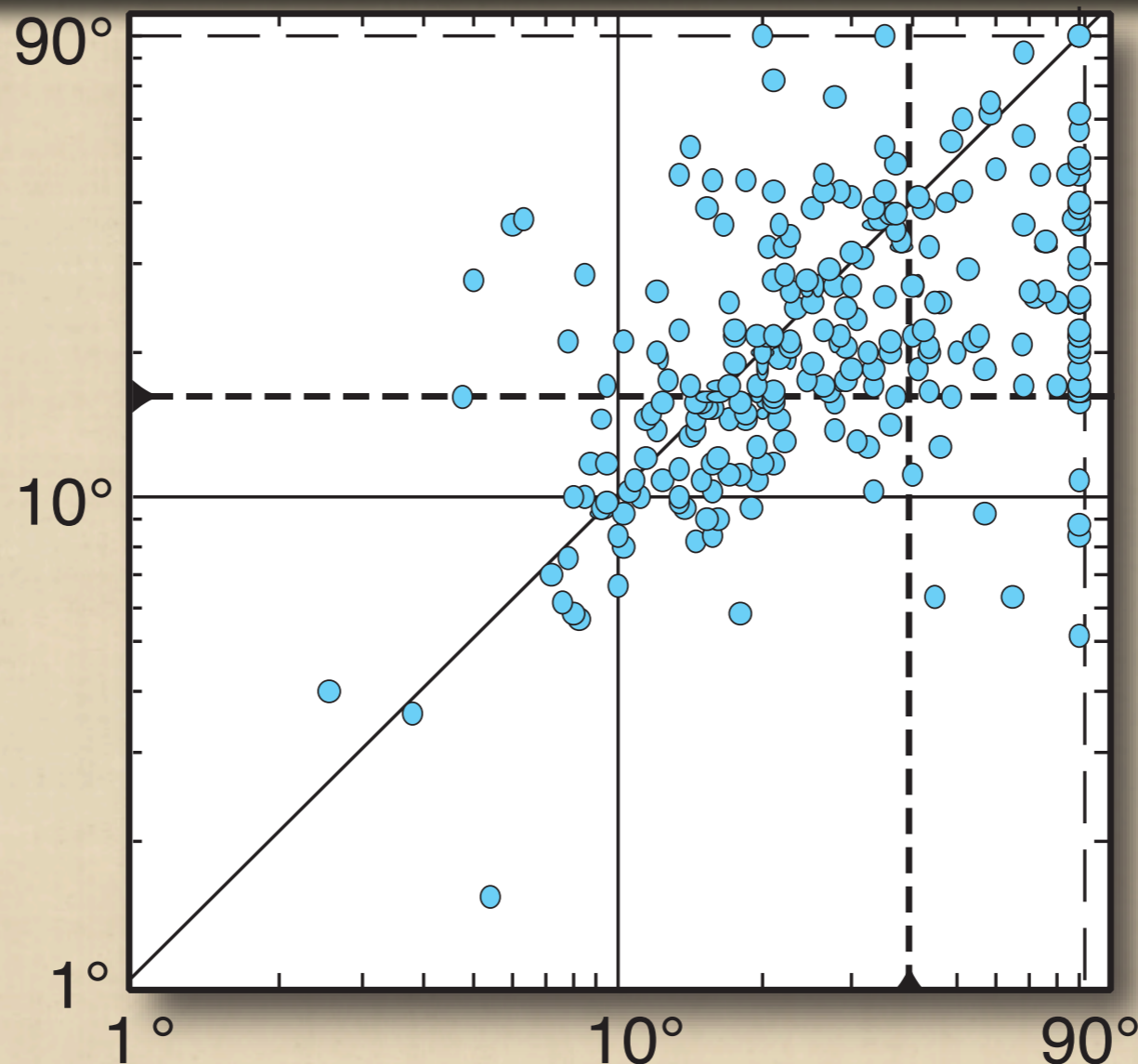

discriminability
ignoring target

Attention affects Fano factor in Area V4

Mitchell et al. 2007

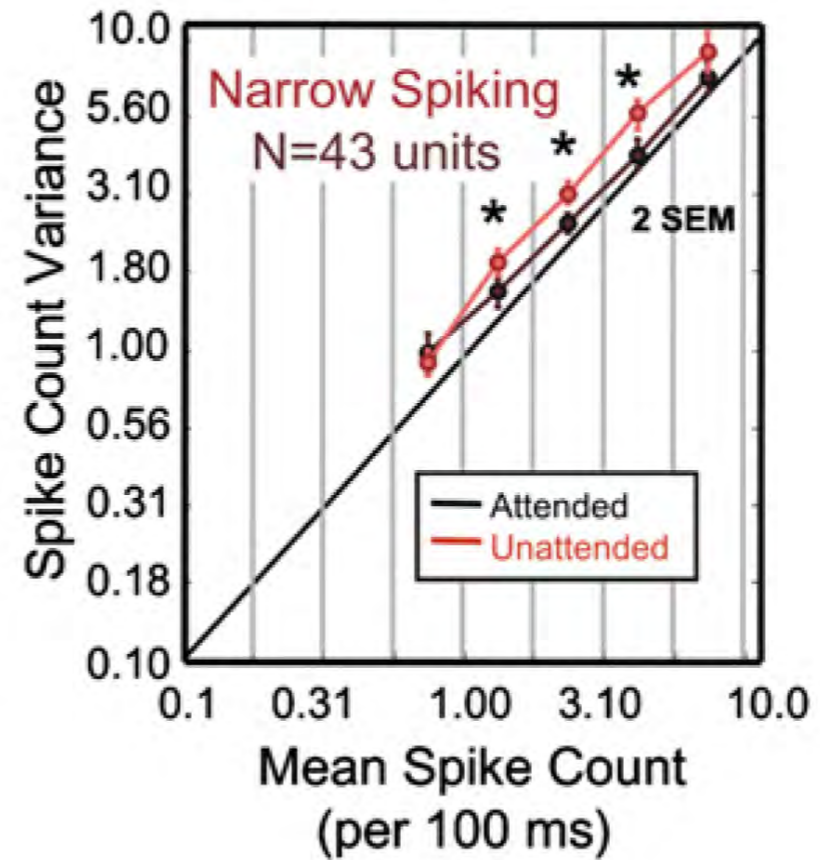
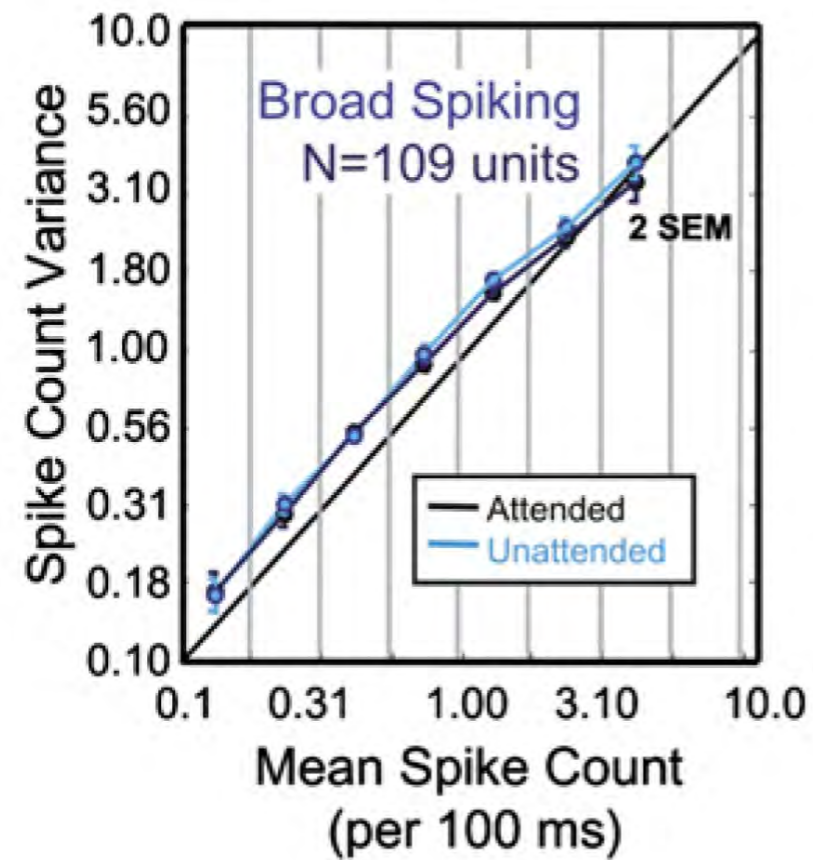





Attention to Stimuli within a V4 Receptive Field

Moran and Desimone 1985

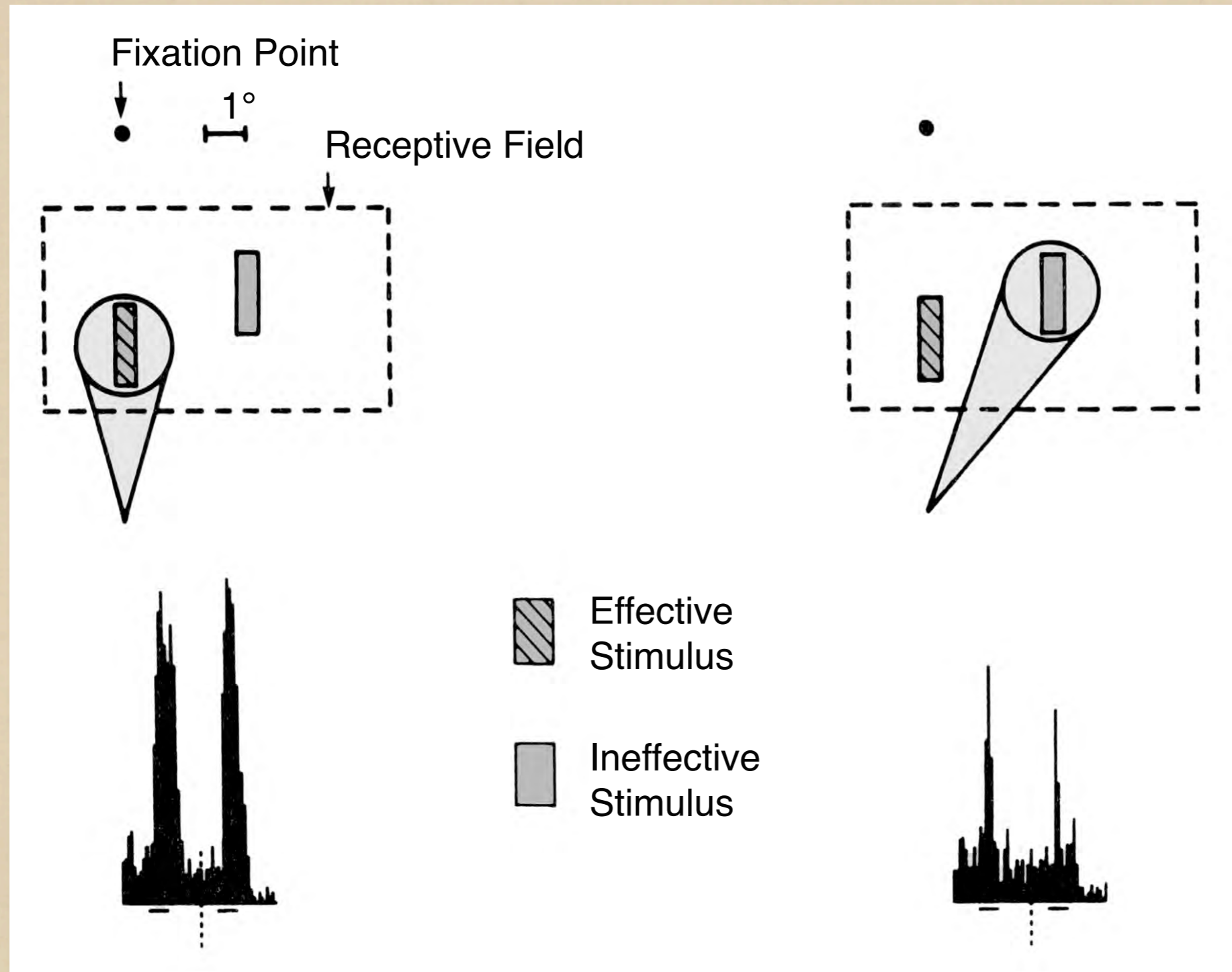

MT responses with attention to one of two receptive field stimuli

Treue & Maunsell, 1996

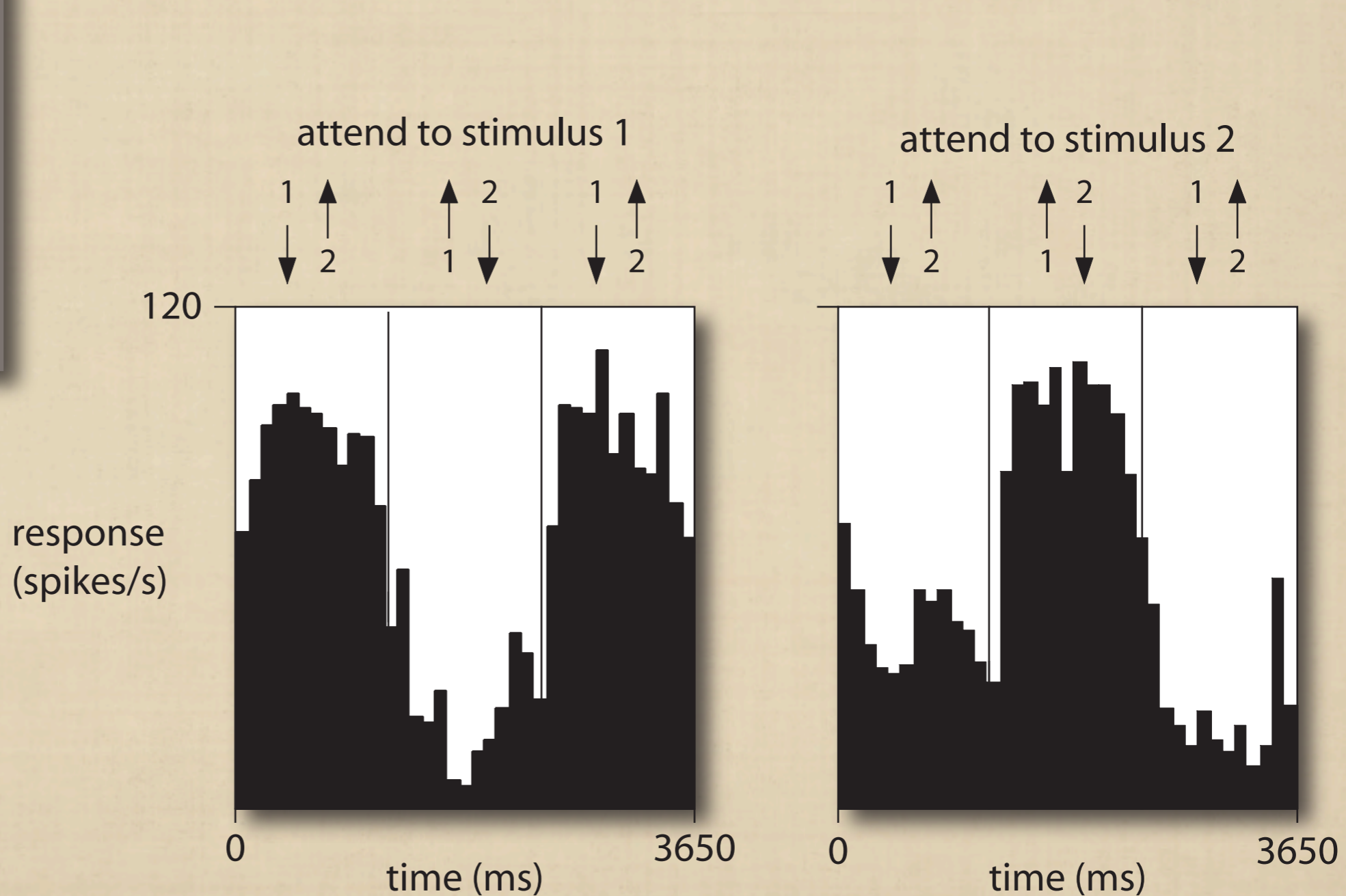
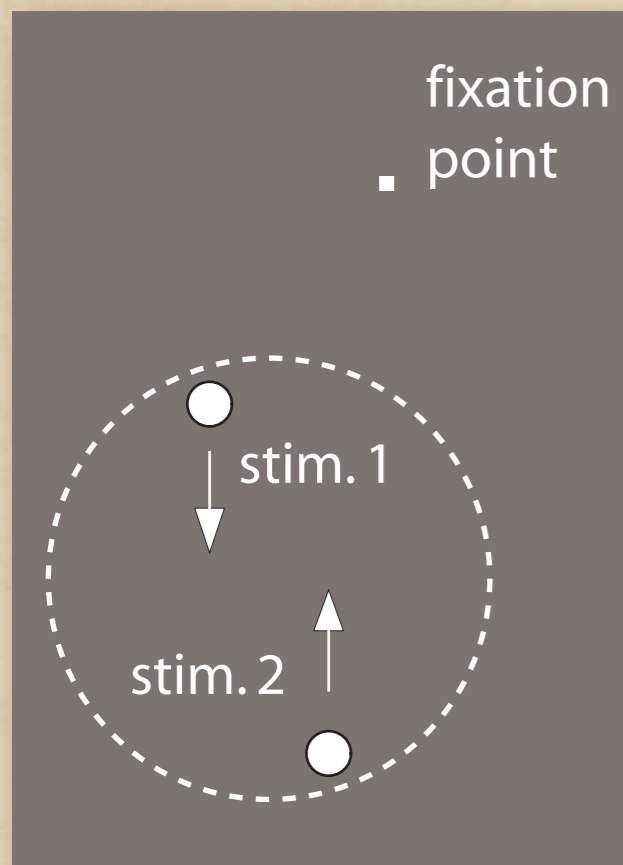

Attention to Grouped Stimuli

Motter 1994

Fixation

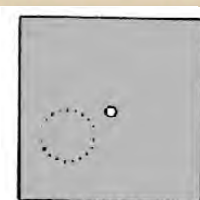

Stimuli

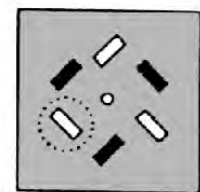

Cue Removed

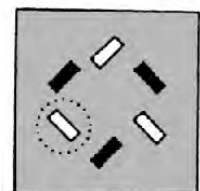

Decision

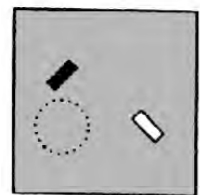

M

NM

M

NM

M

NM

M

NM

300 ms/div

Shifting attention between two stimuli inside the receptive field of a neuron in MT

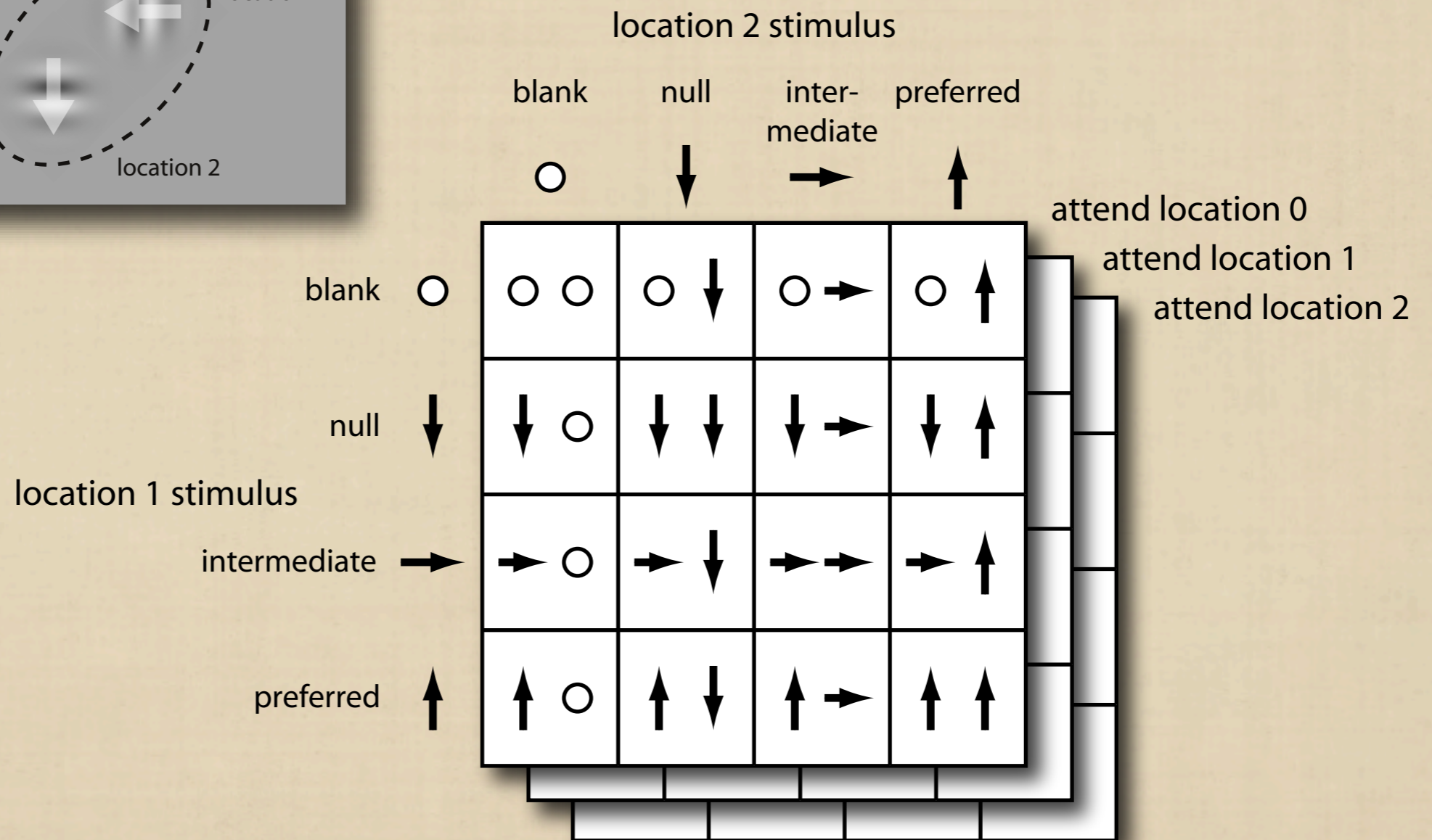
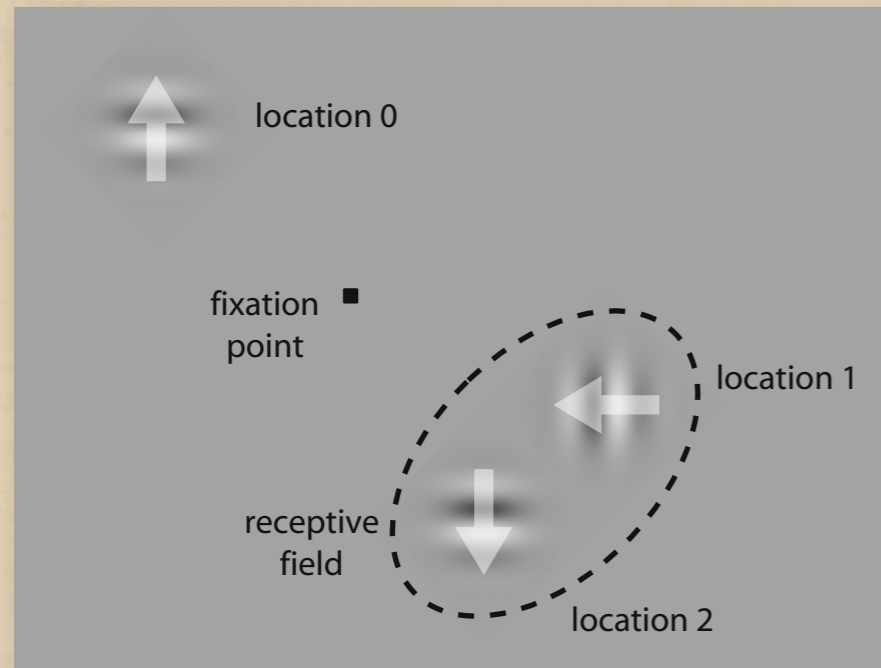

Responses of an MT neuron to different stimulus pairings and attentional states

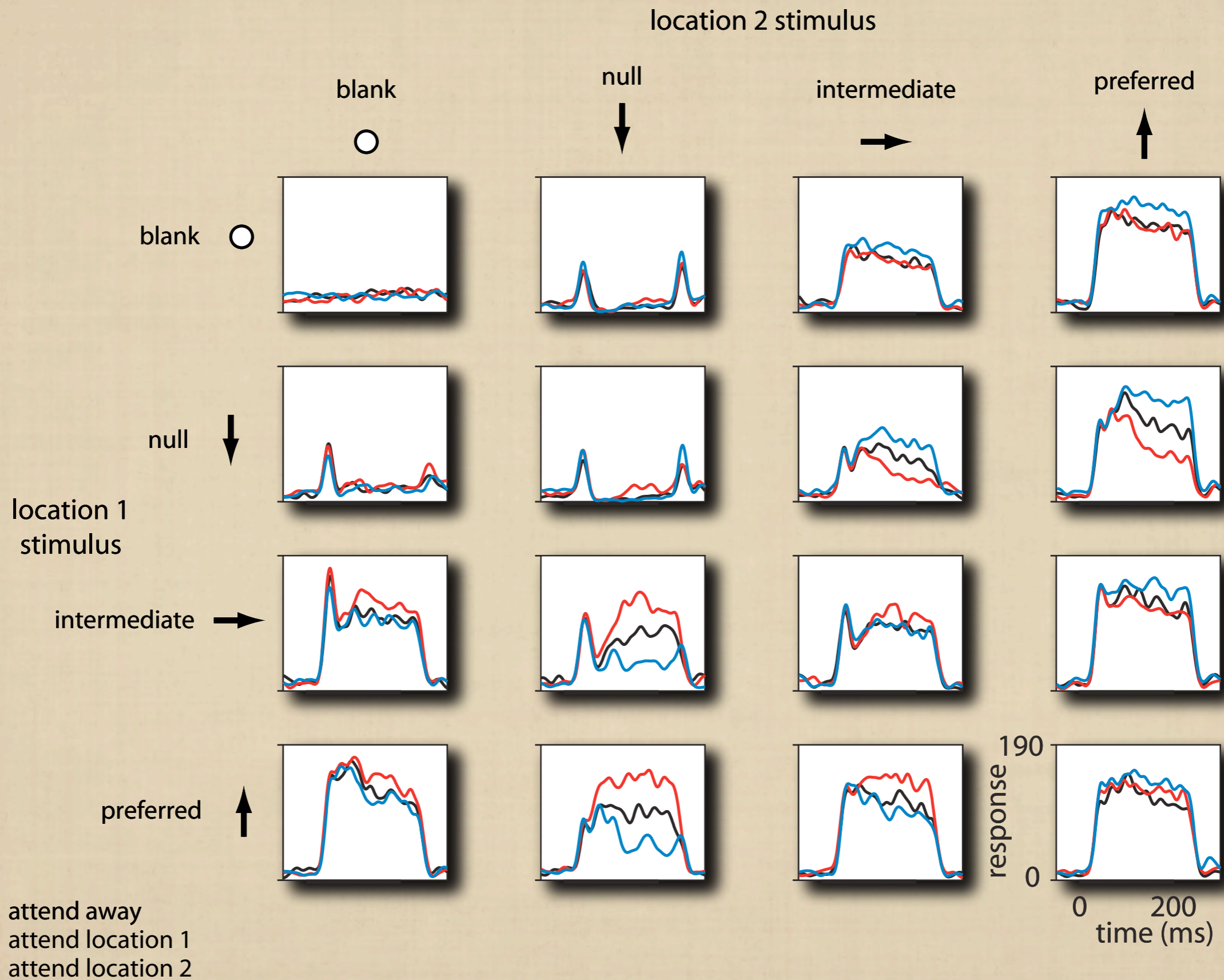

MT population average responses to different stimulus pairings and attentional states

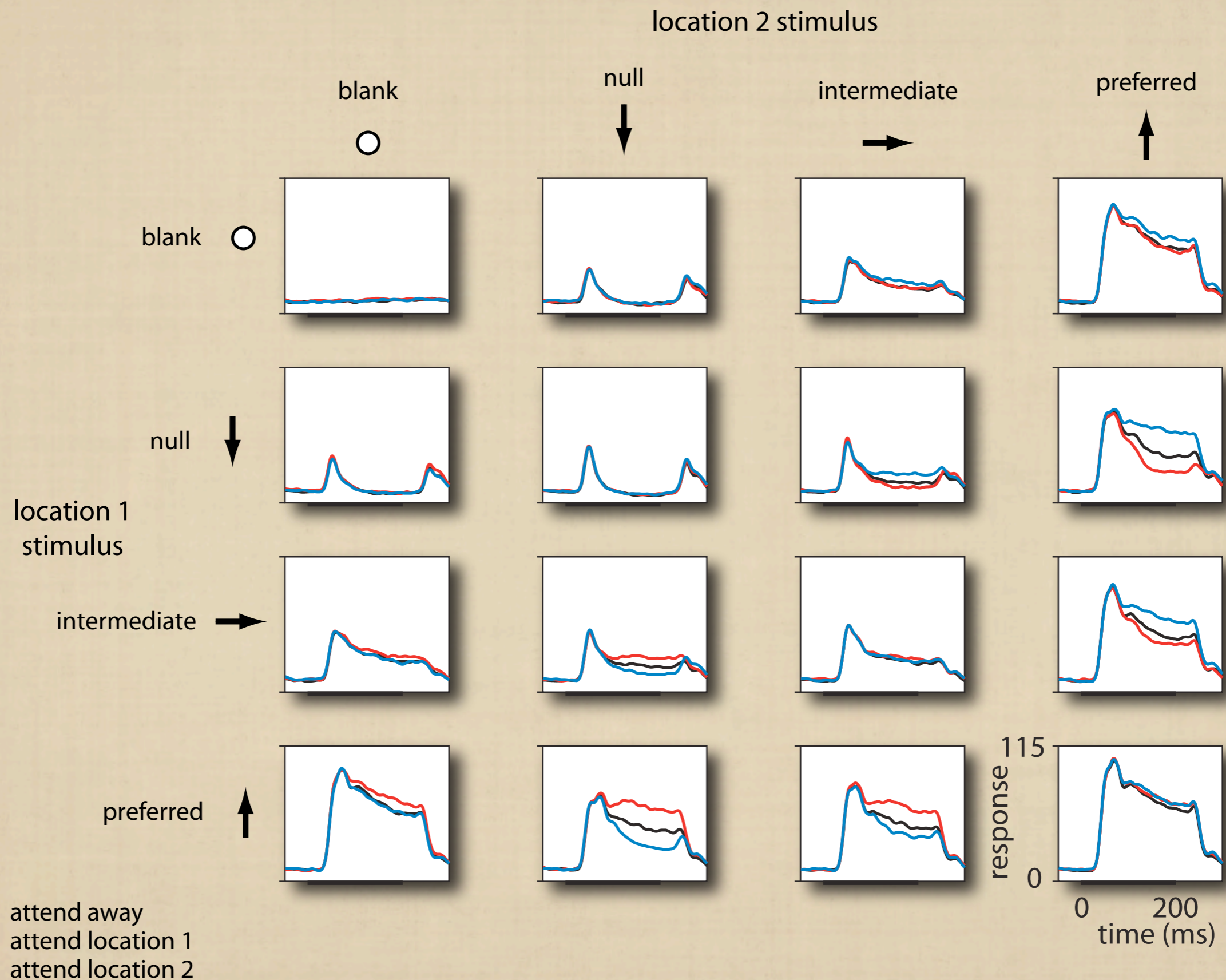

MT neuron

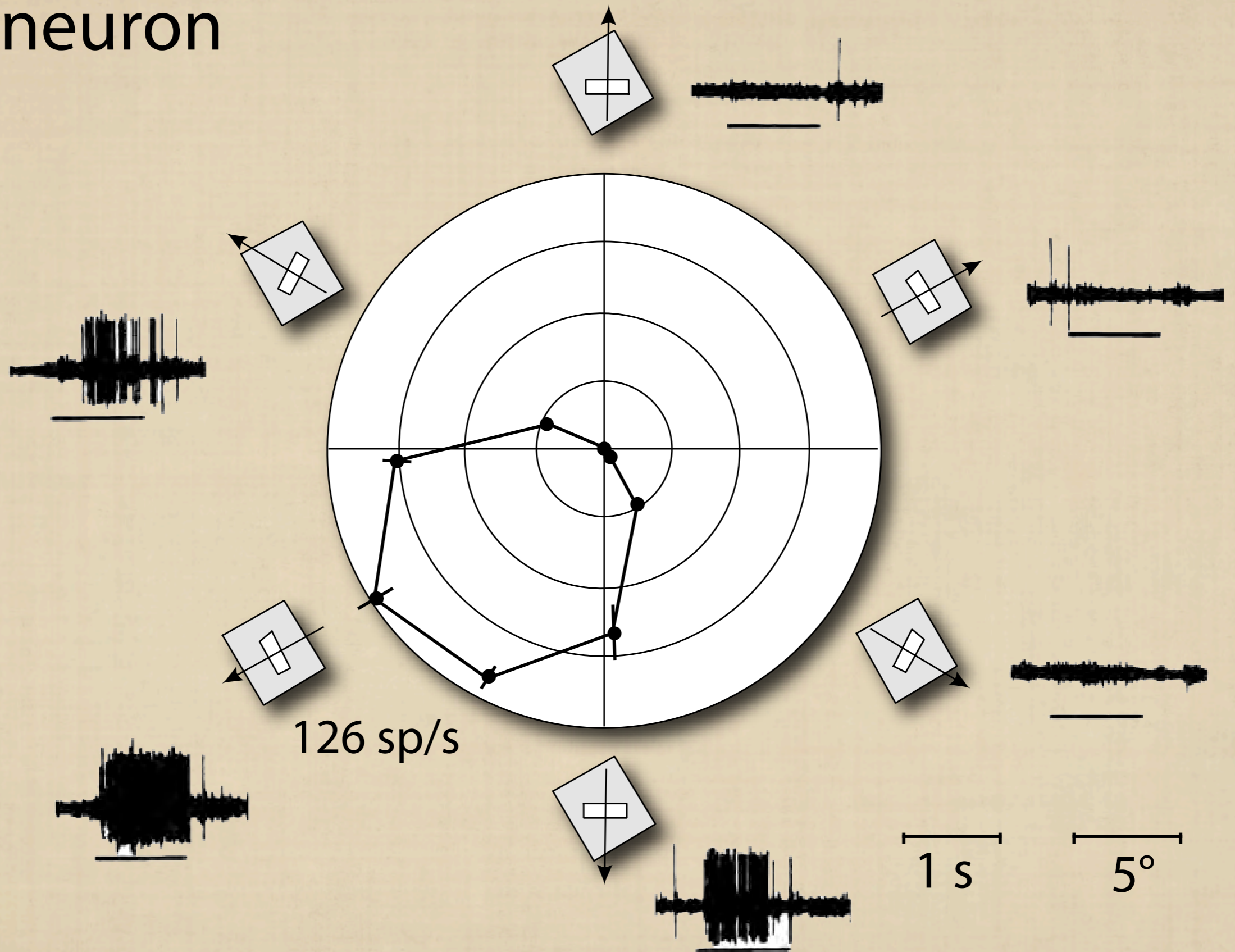

Normalization of neuronal responses

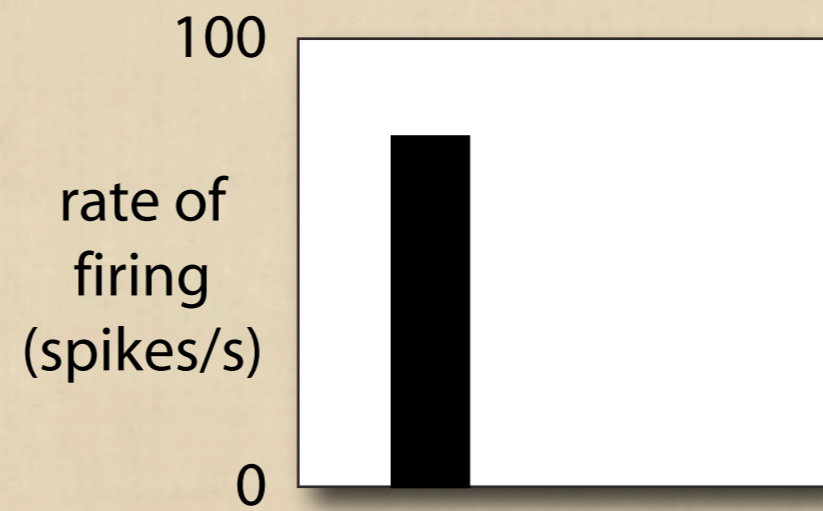
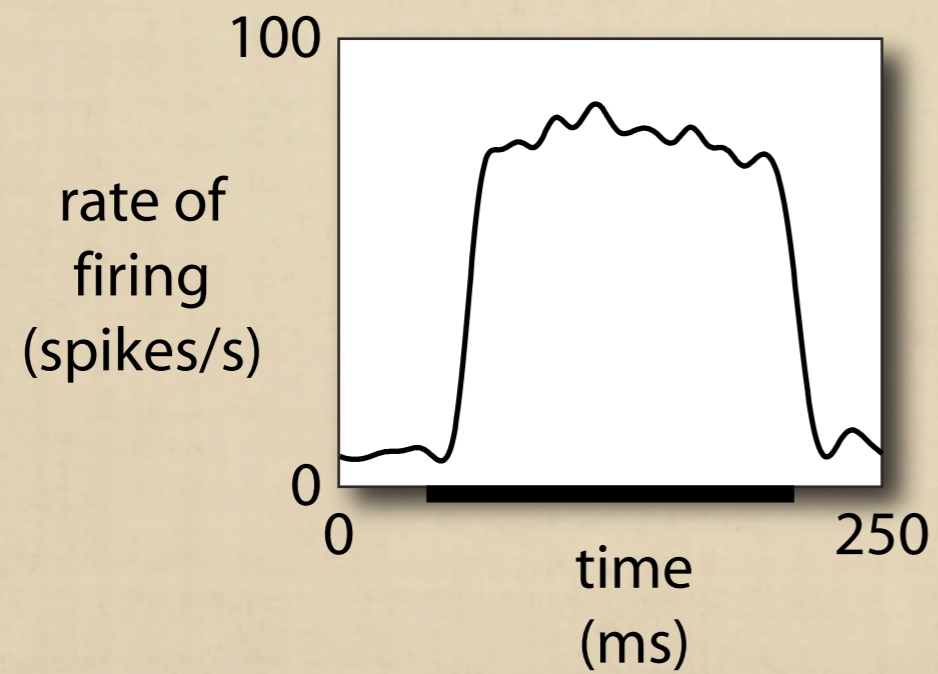
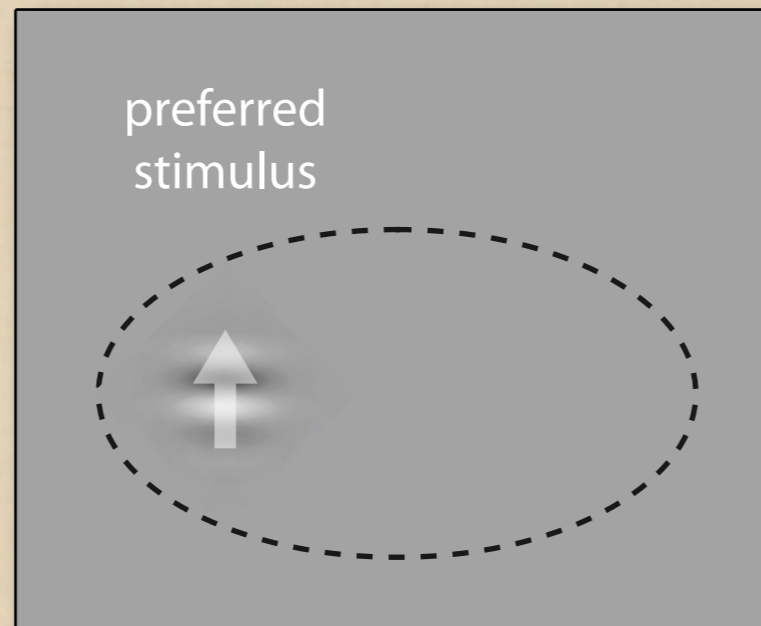

Normalization of neuronal responses

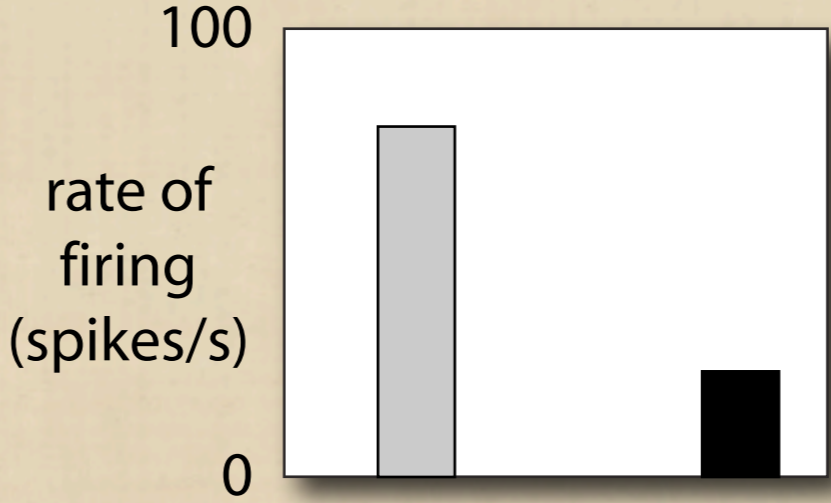
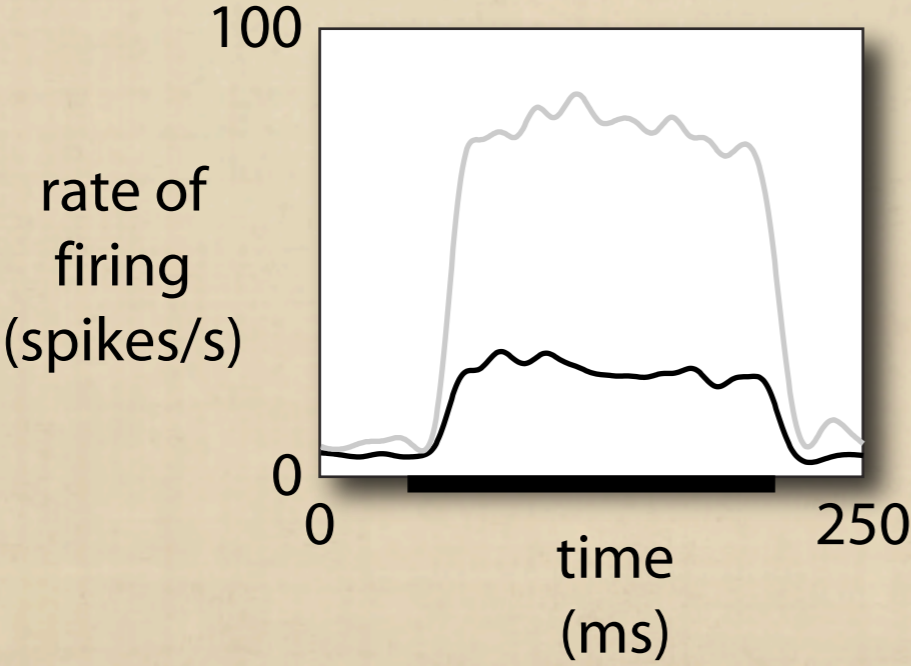
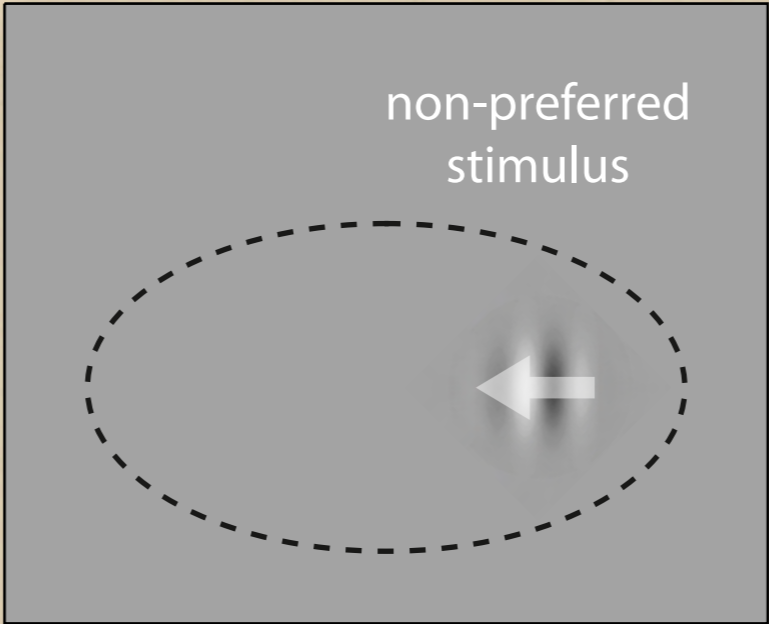

Normalization of neuronal responses

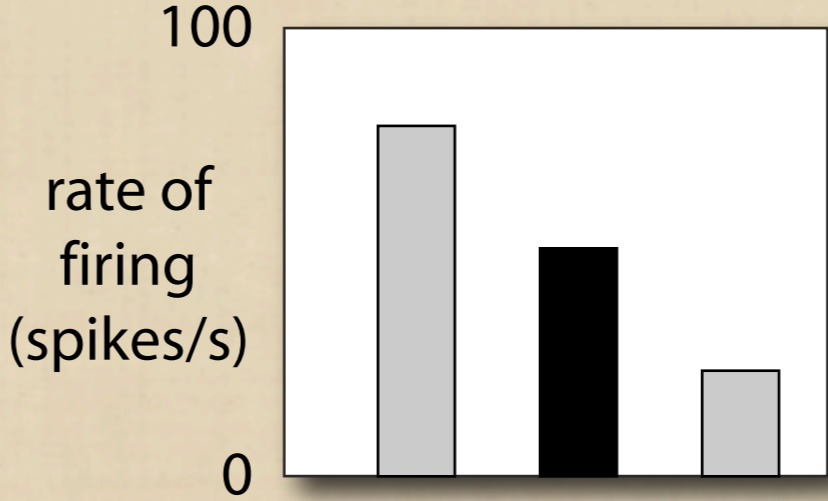
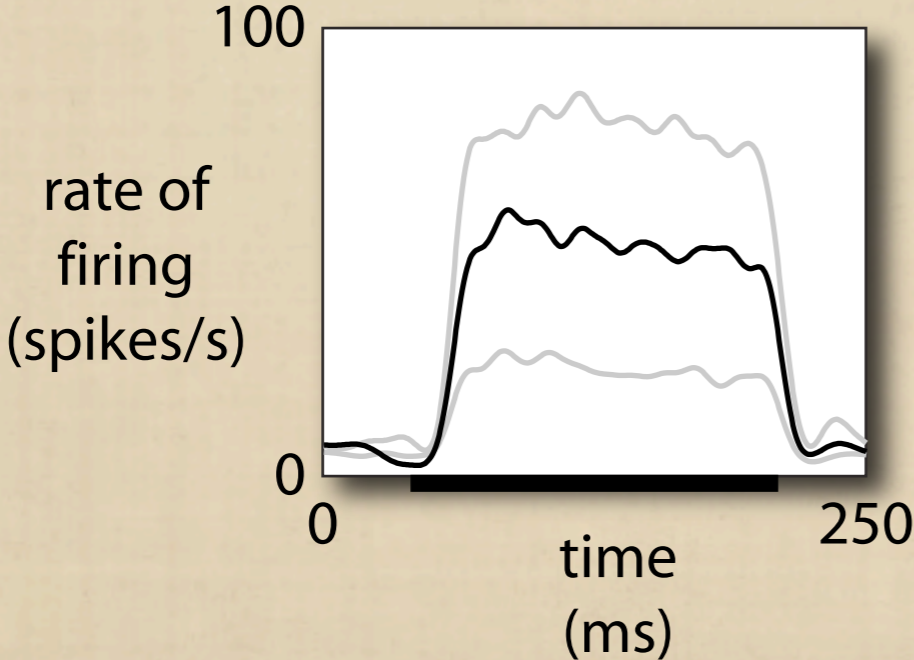
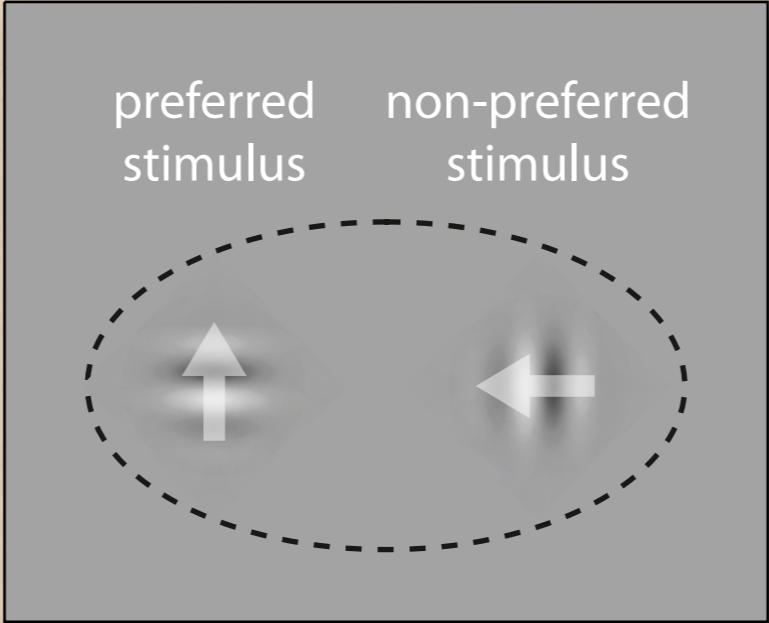

Normalization of neuronal responses

Heeger et al. 1996

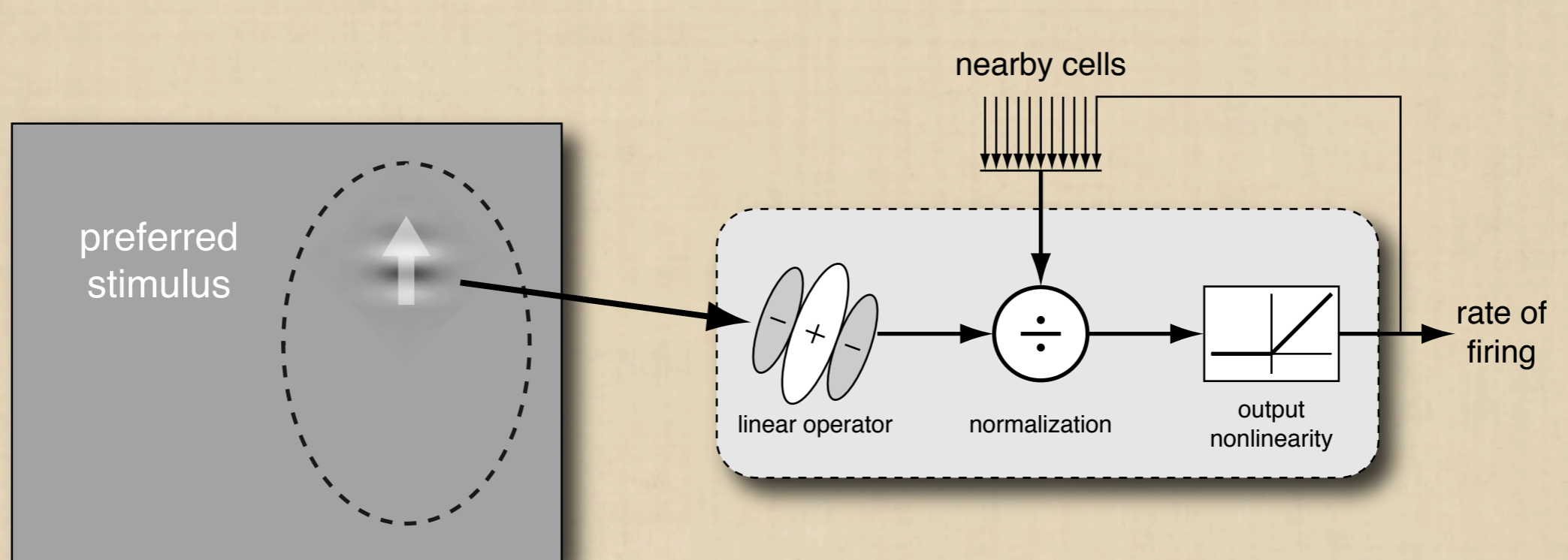

Normalization of neuronal responses

Heeger et al. 1996

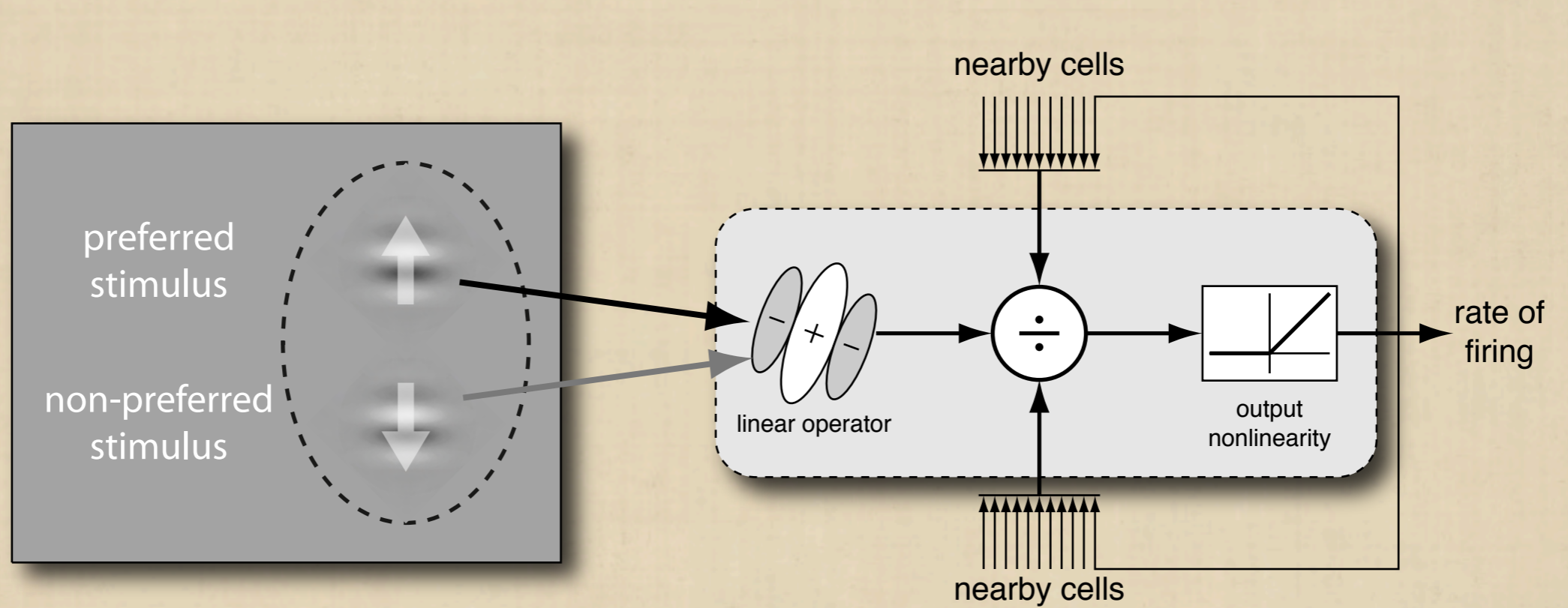

Attention Normalization Model

Lee & Maunsell (2009)

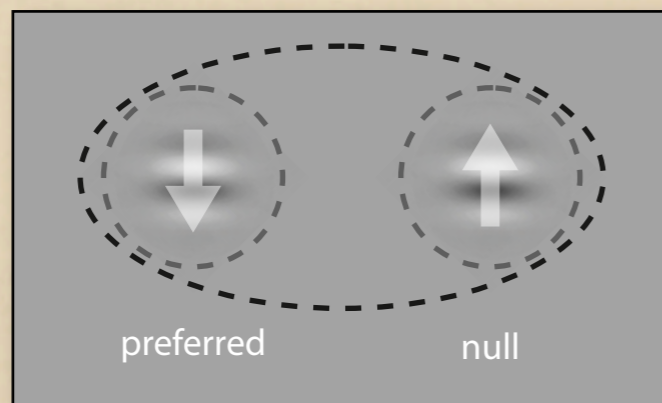
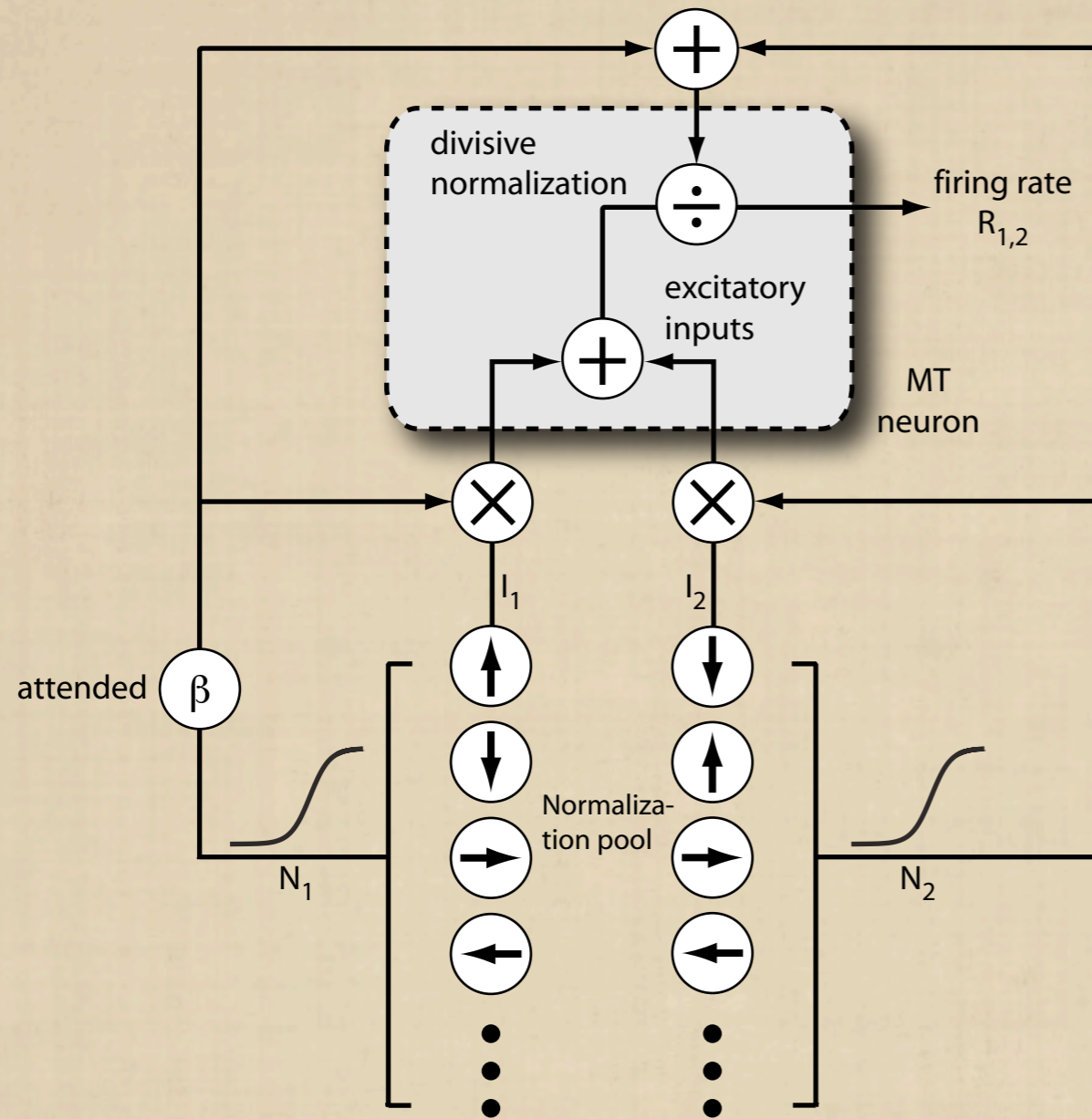

$$R_{1,2} = \left(\left(\frac{I_1 \cdot N_1}{N_1 + N_2} \right)^n + \left(\frac{I_2 \cdot N_2}{N_1 + N_2} \right)^n \right)^{\frac{1}{n}}$$

attended:

$$N = s + (1 - s) \cdot (1 - e^{-c\alpha\beta})$$

ignored:

$$N = s + (1 - s) \cdot (1 - e^{-c\alpha})$$

MT population average responses to different stimulus pairings and attentional states

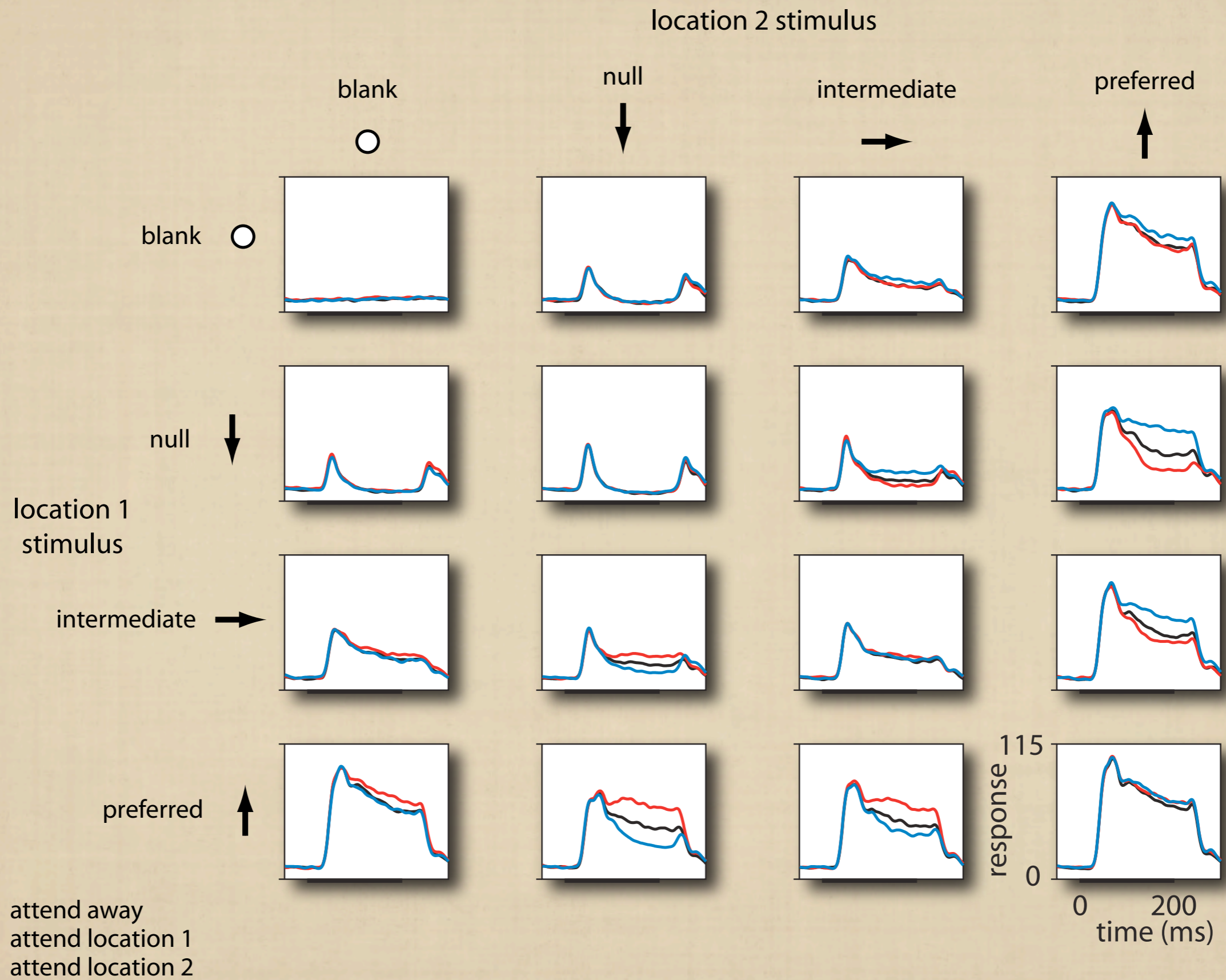

Responses of an MT neuron and fit of normalization model

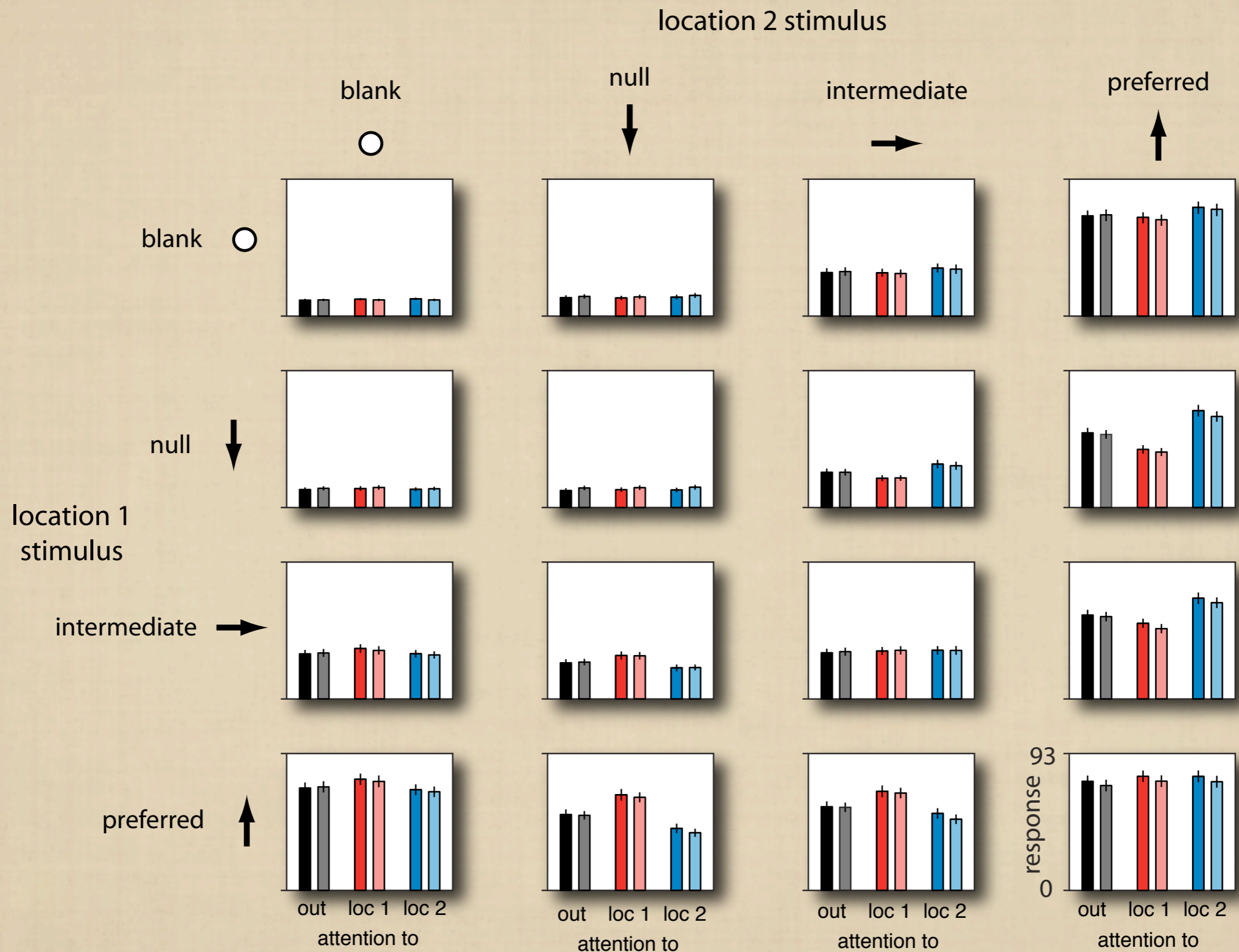

Two stimuli in the receptive field with different contrasts

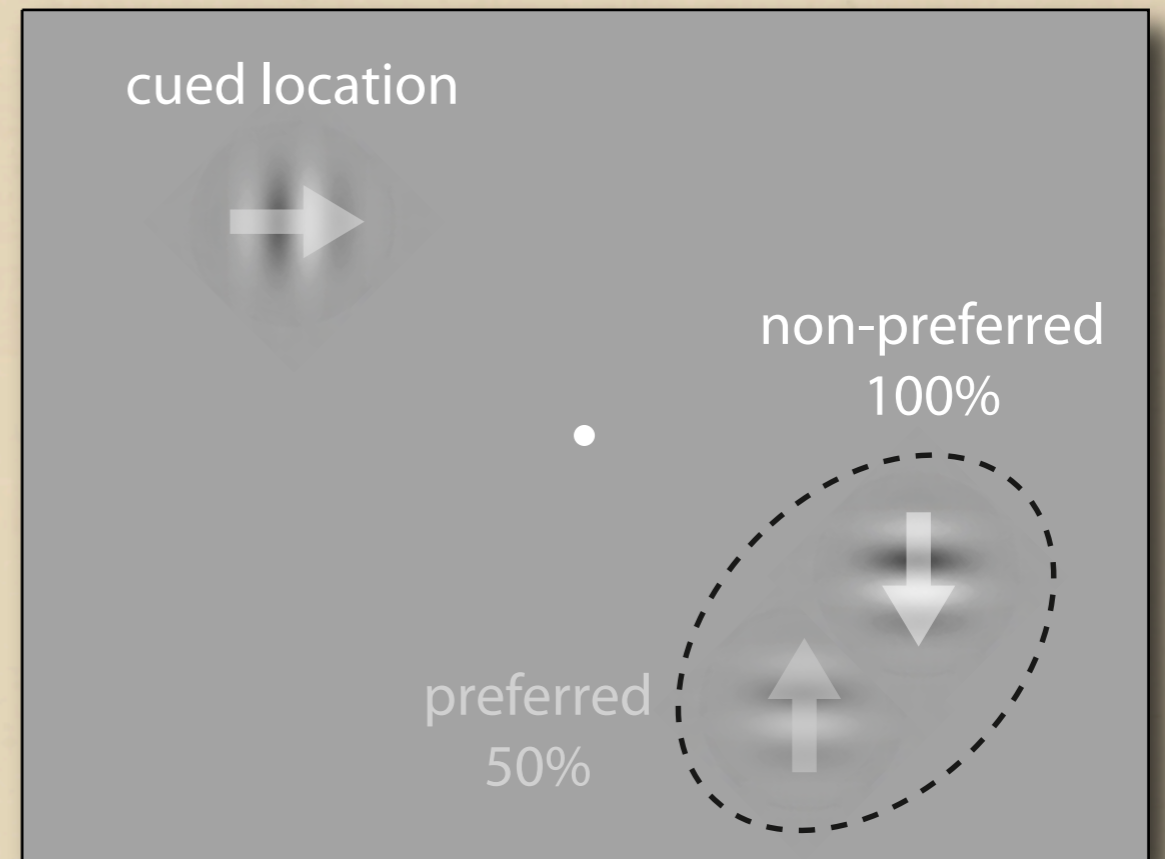
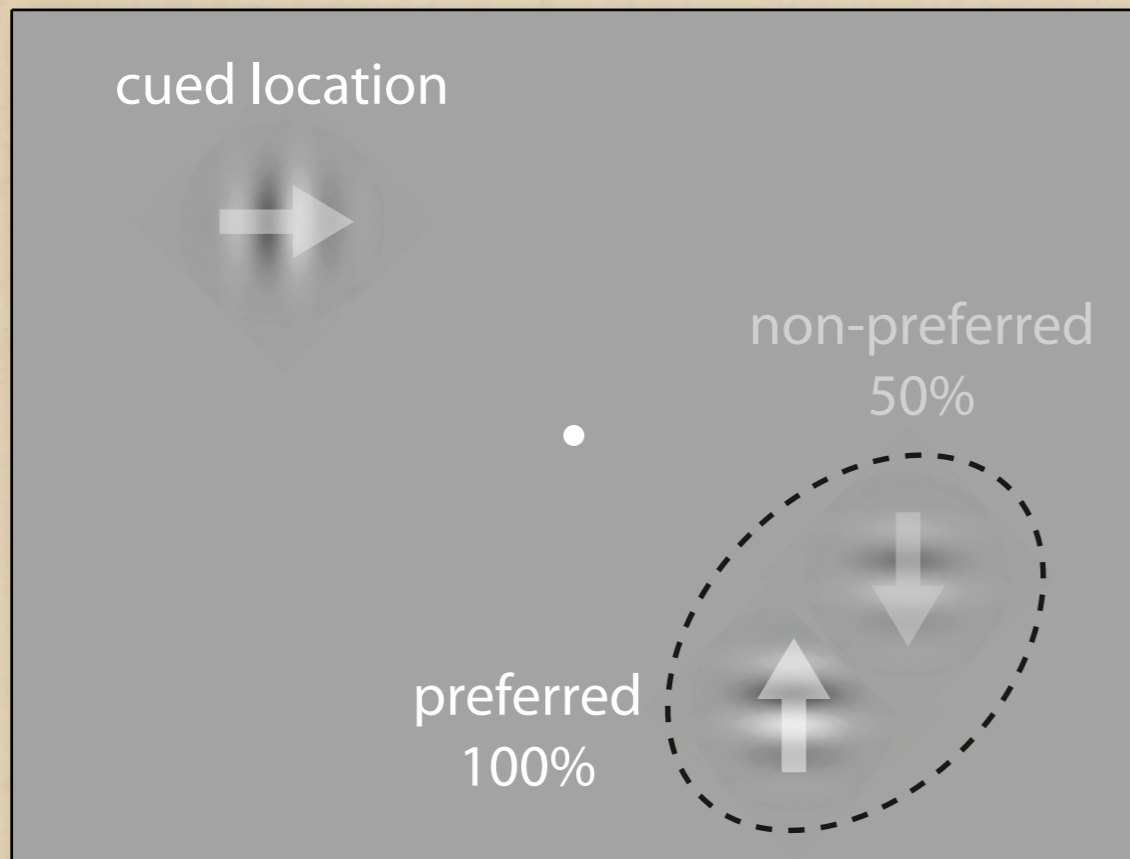

Effect of contrast offset on the response functions of an MT neuron

attention fixed
relative contrast varied

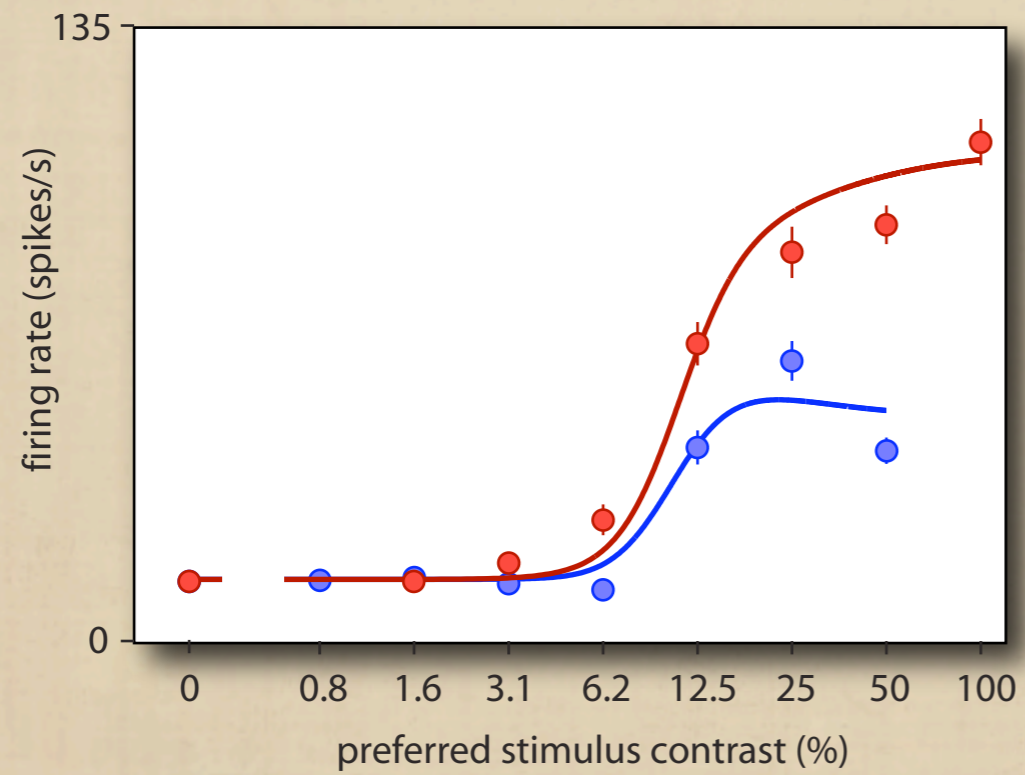
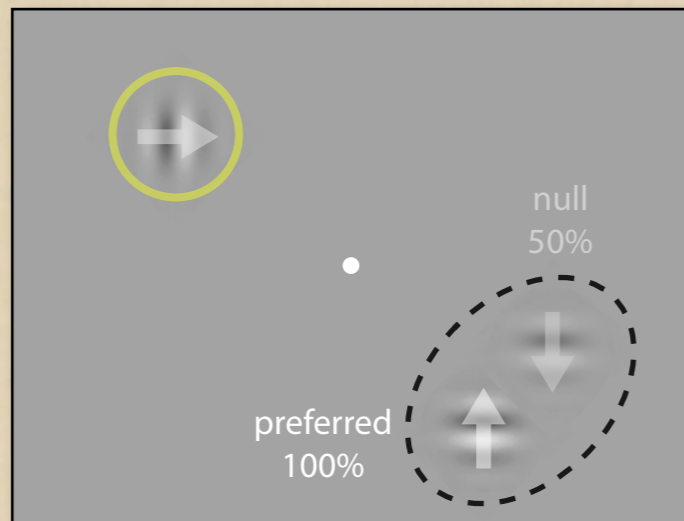

Effect of contrast offset on the response functions of an MT neuron

attention fixed
relative contrast varied

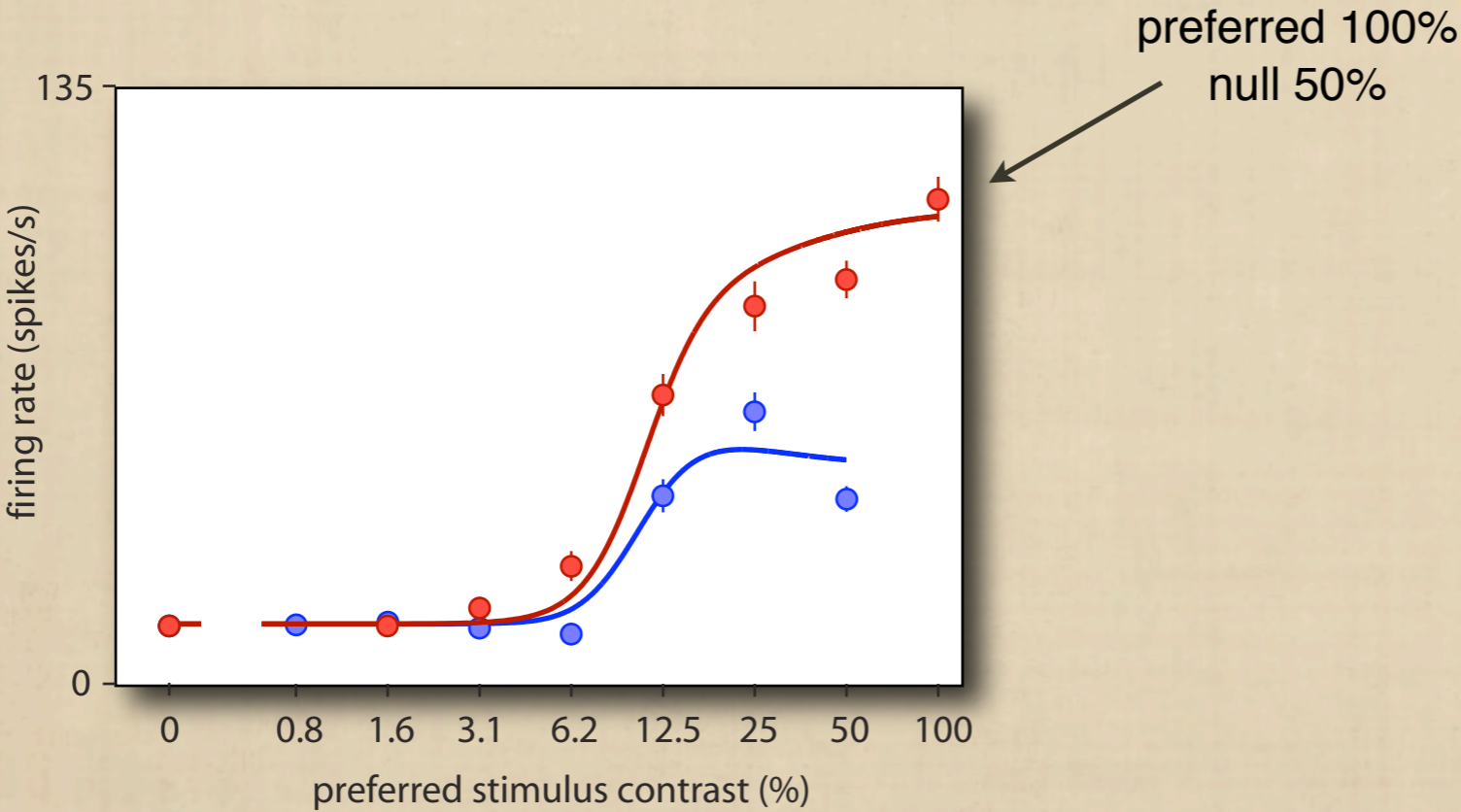

Effect of contrast offset on the response functions of an MT neuron

attention fixed
relative contrast varied

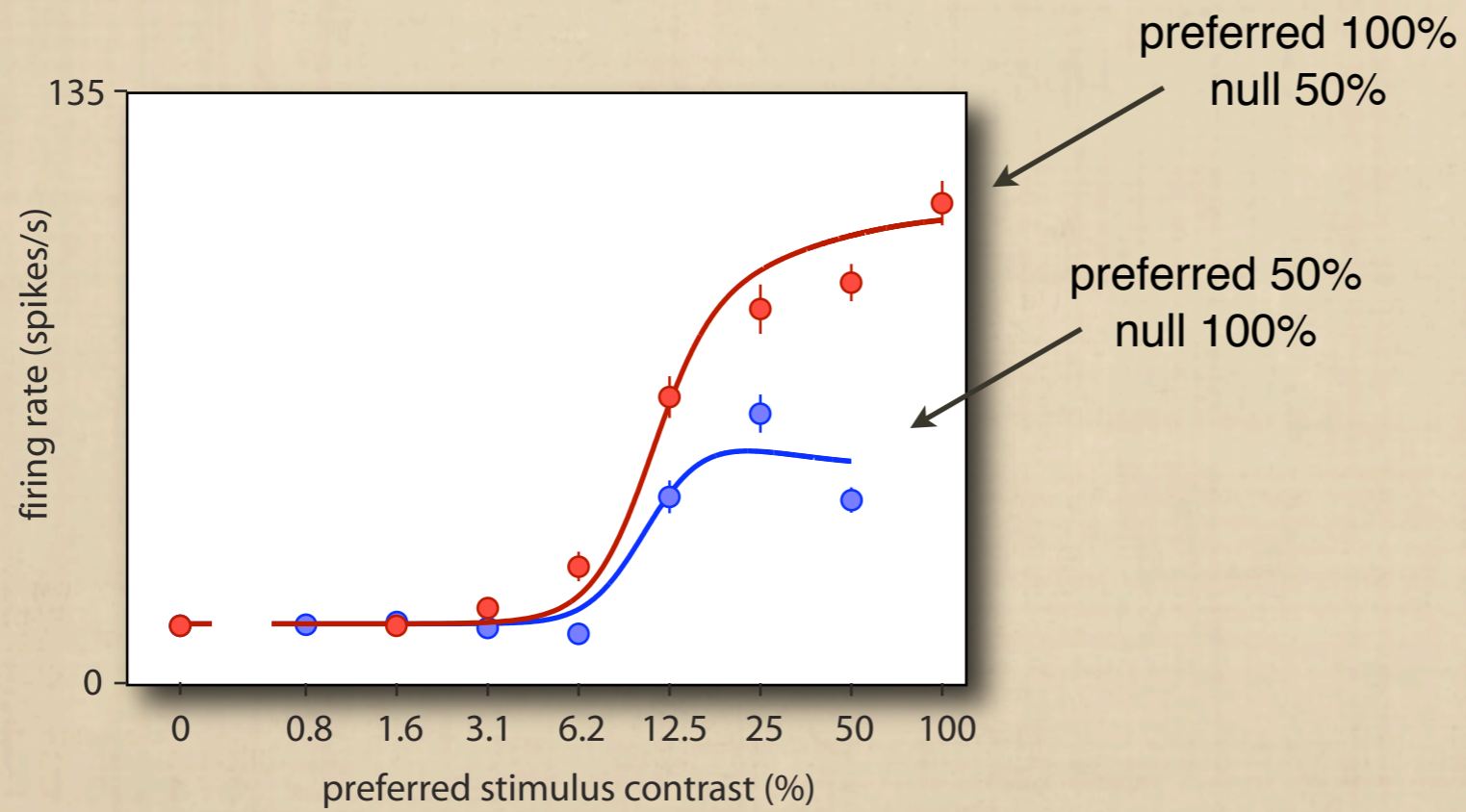
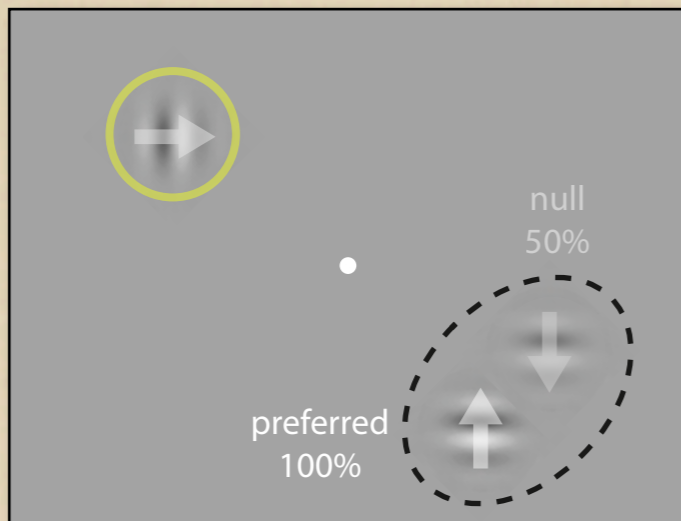

Contrast response functions of an MT neuron with strong modulation

attention fixed
relative contrast varied

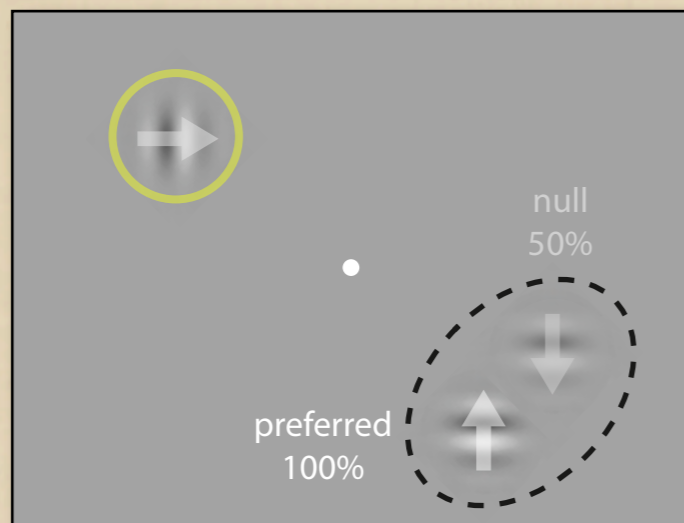

attention varied
relative contrast fixed

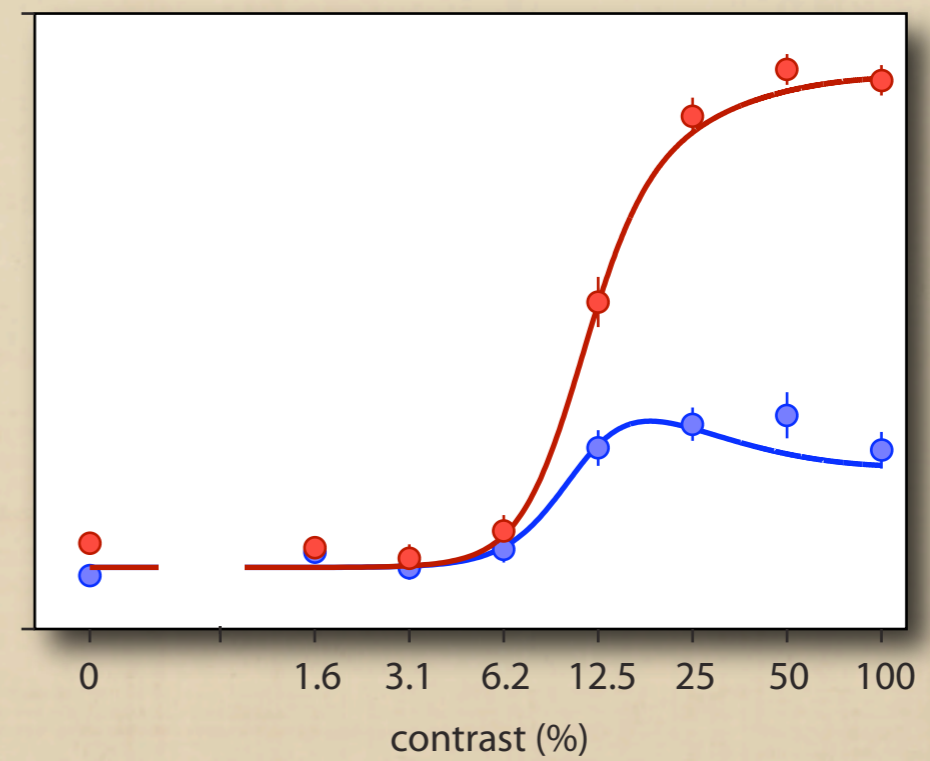
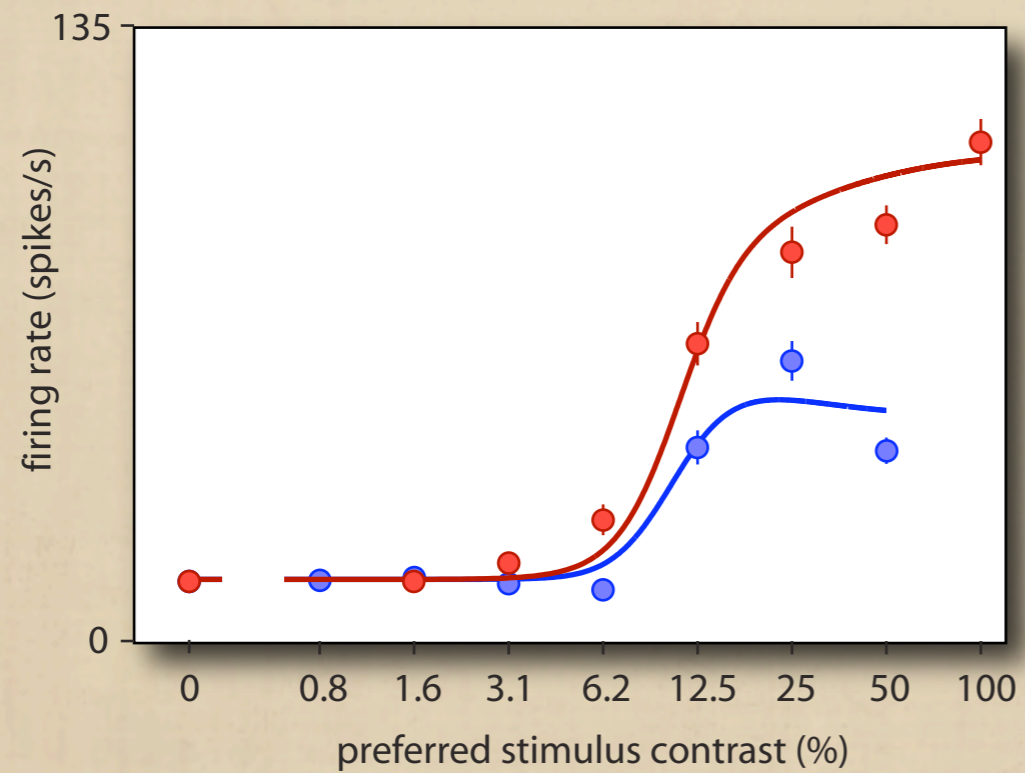
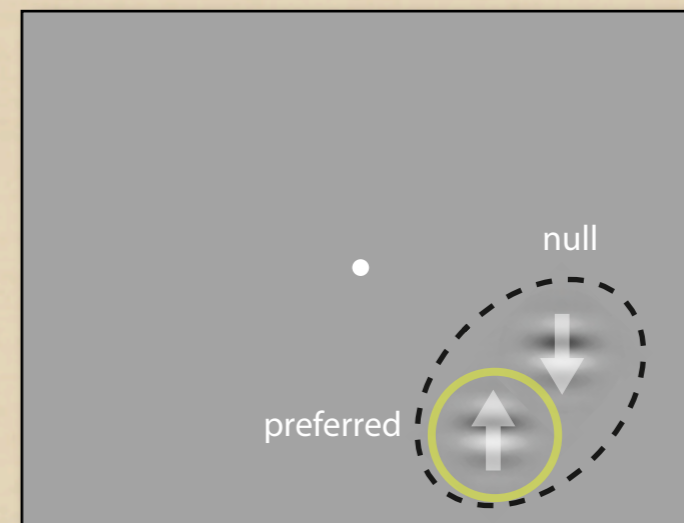

Contrast response functions of an MT neuron with weak modulation

attention fixed
relative contrast varied

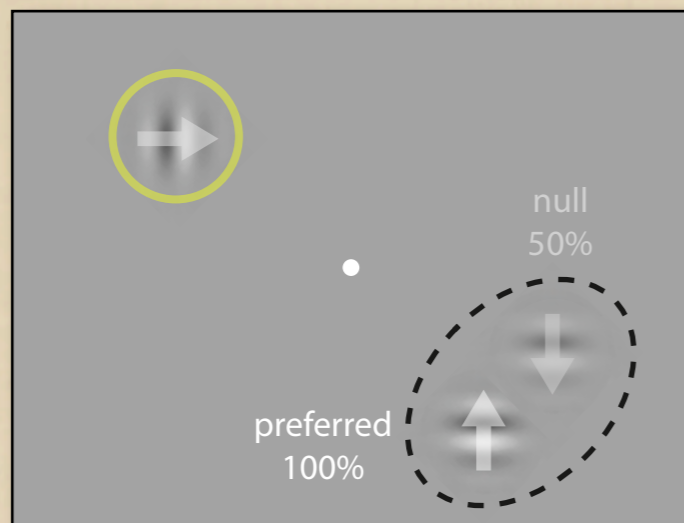

attention varied
relative contrast fixed

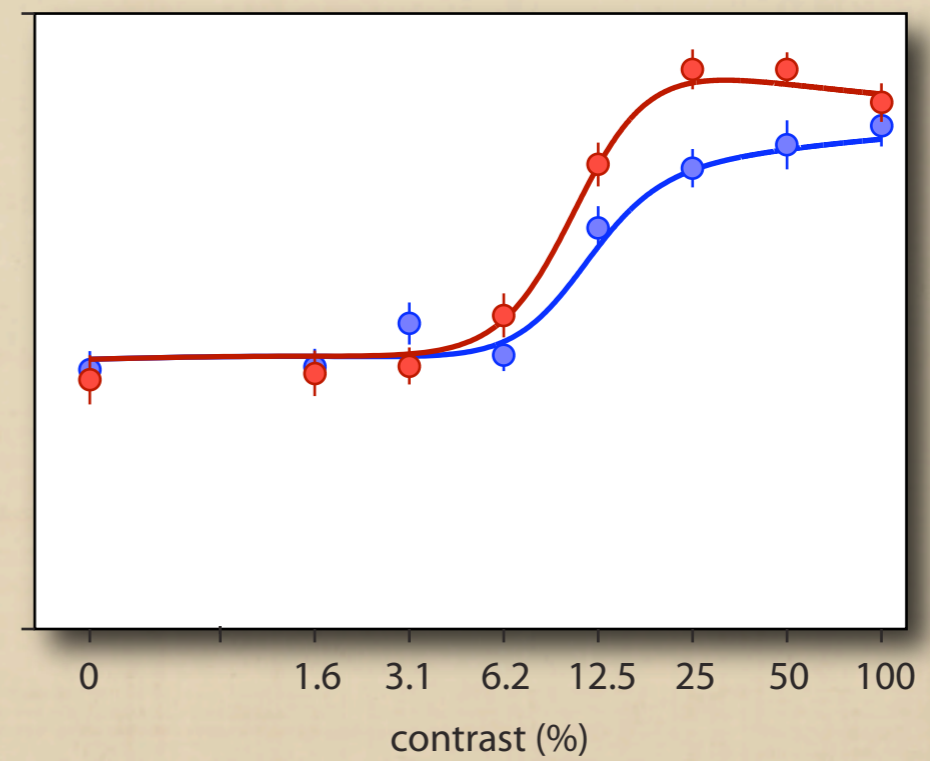
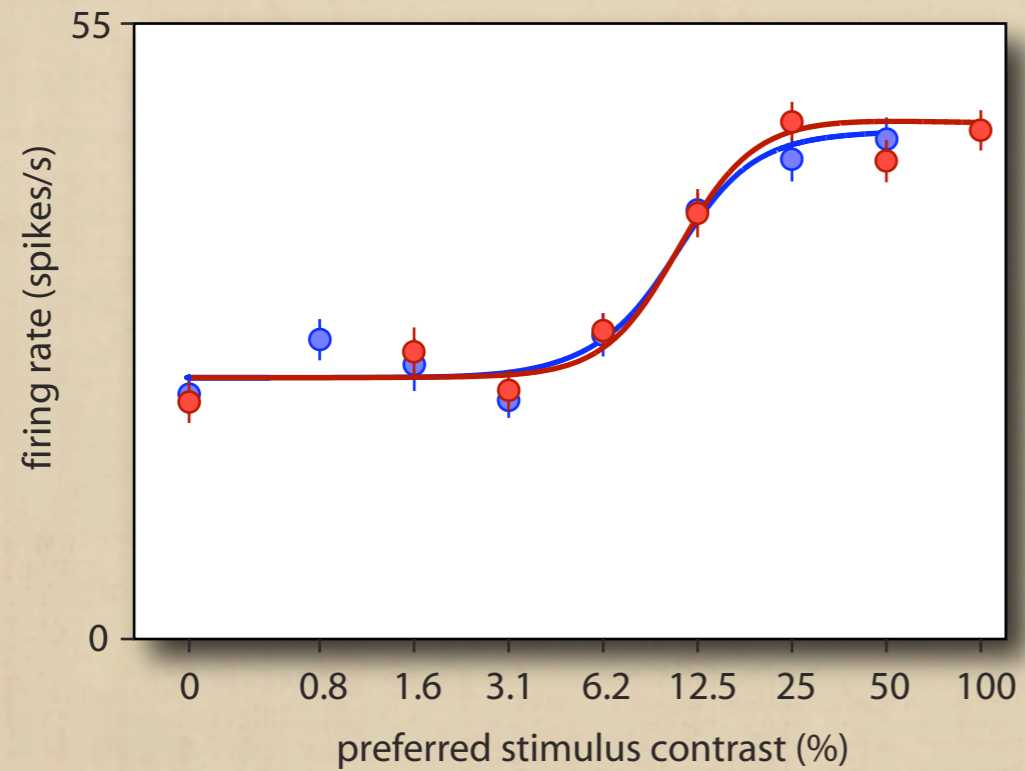
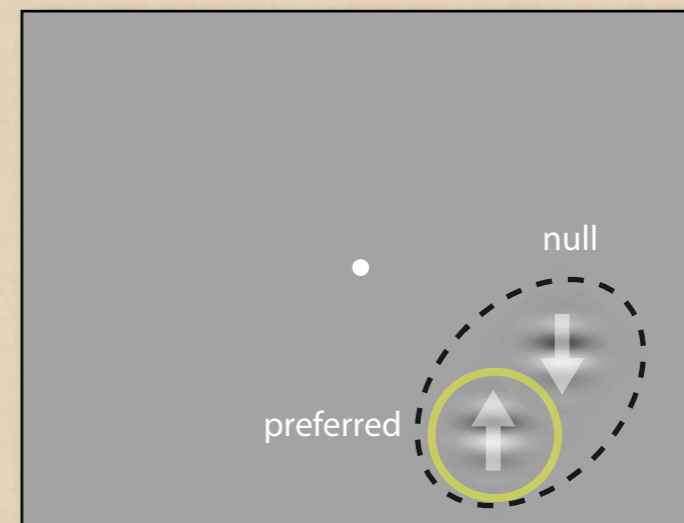

Modulation by attention is correlated to modulation by stimulus interactions

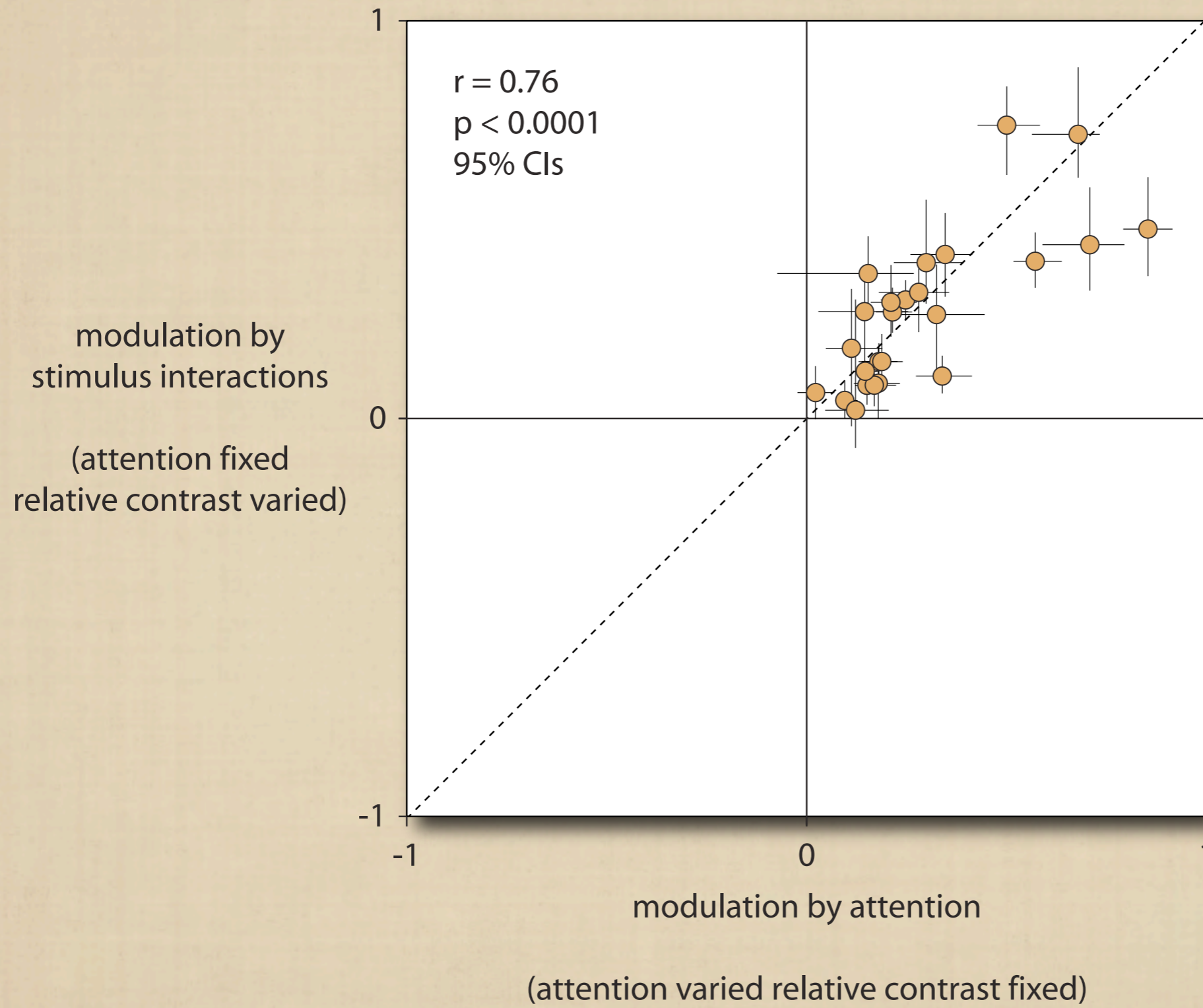

Modeling attentional normalization

$$R_{1,2} = \left(\left(\frac{I_1 \cdot N_1}{N_1 + N_2} \right)^n + \left(\frac{I_2 \cdot N_2}{N_1 + N_2} \right)^n \right)^{\frac{1}{n}}$$

$$N = s + (1 - s) \cdot (1 - e^{-c\alpha\beta})$$

attention fixed
relative contrast varied

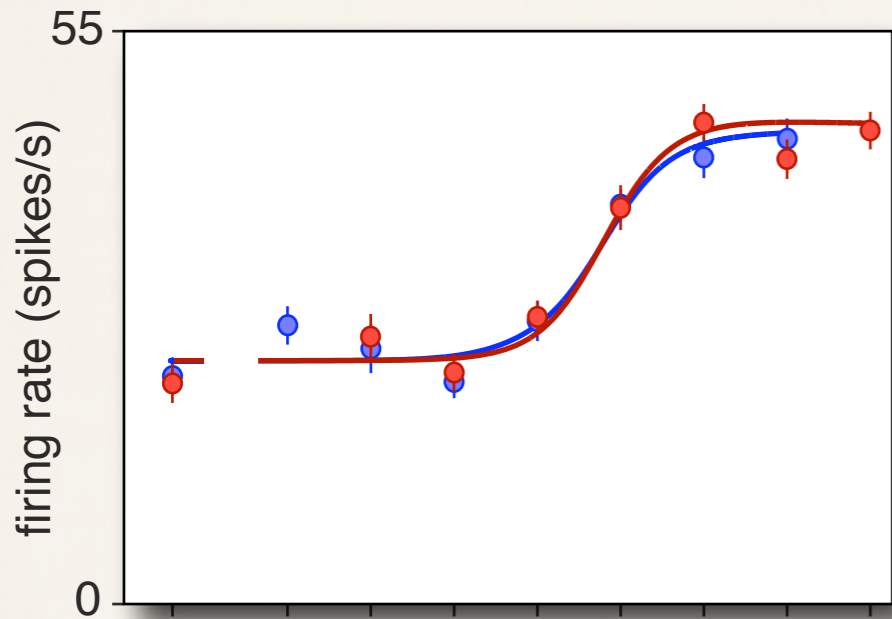

attention varied
relative contrast fixed

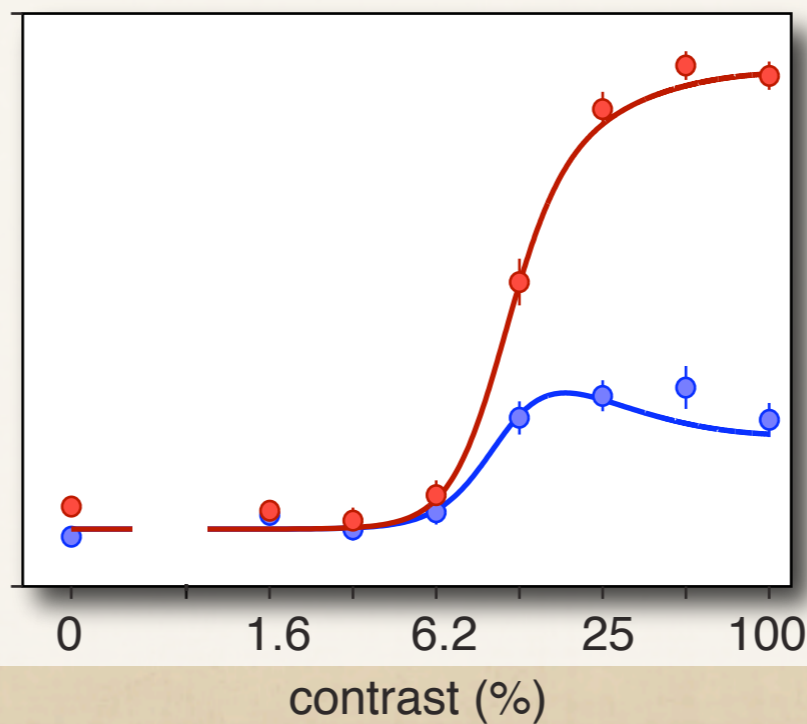
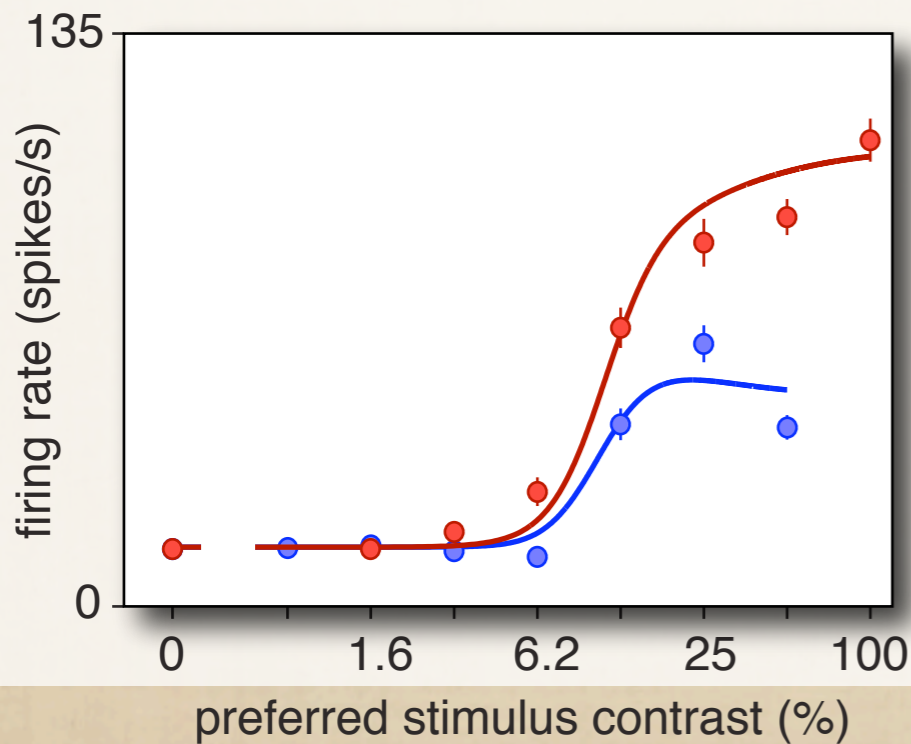
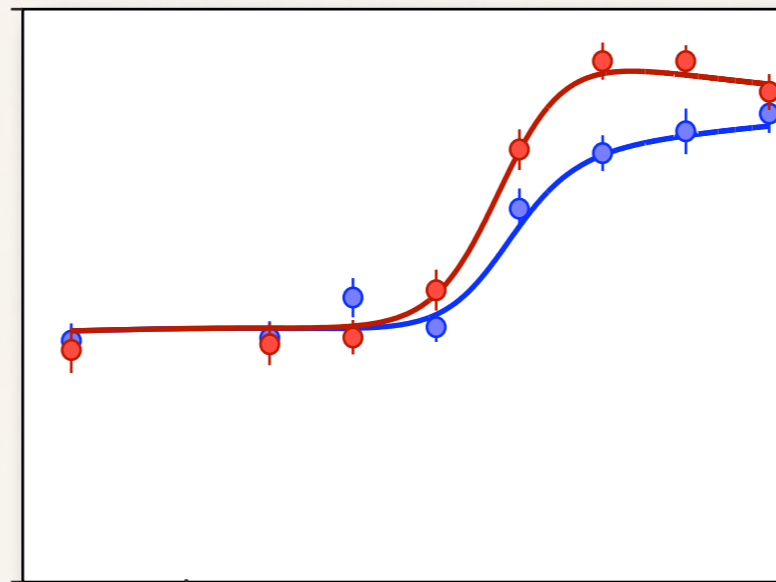

Subthreshold FEF electrical stimulation locally improves detection of a luminance change

Moore & Fallah 2001, 2004

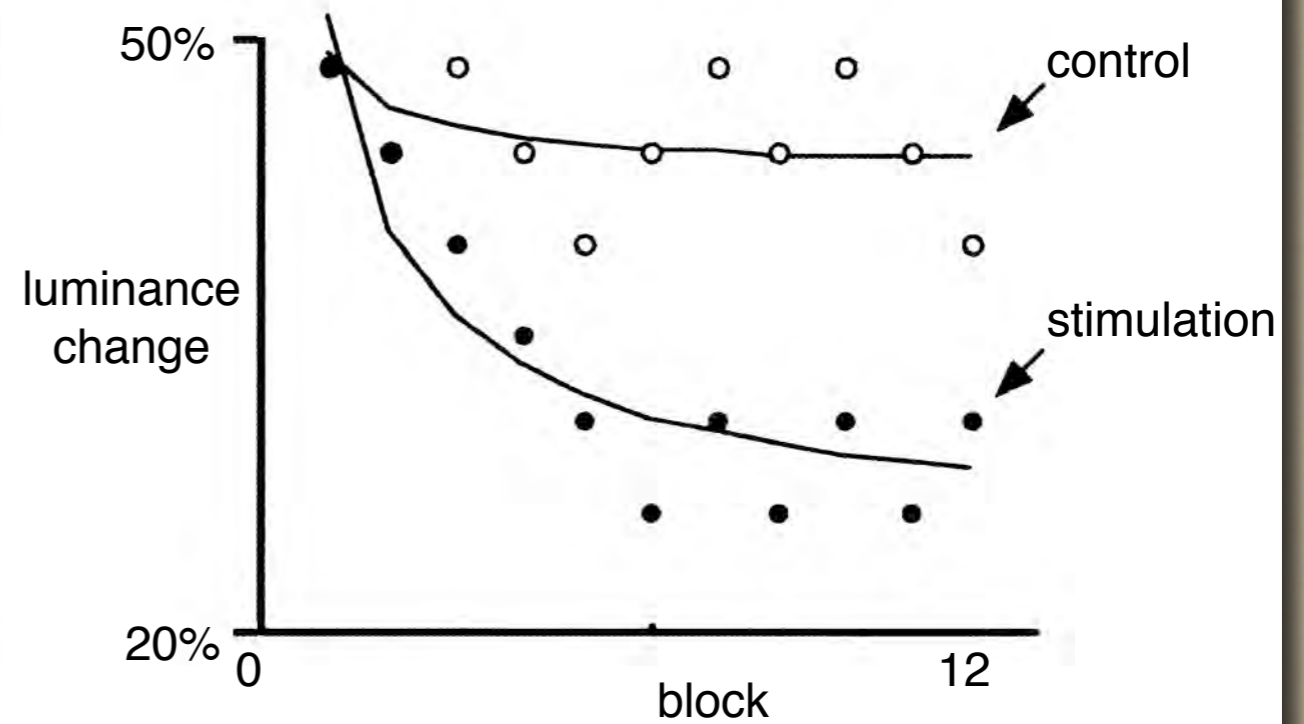
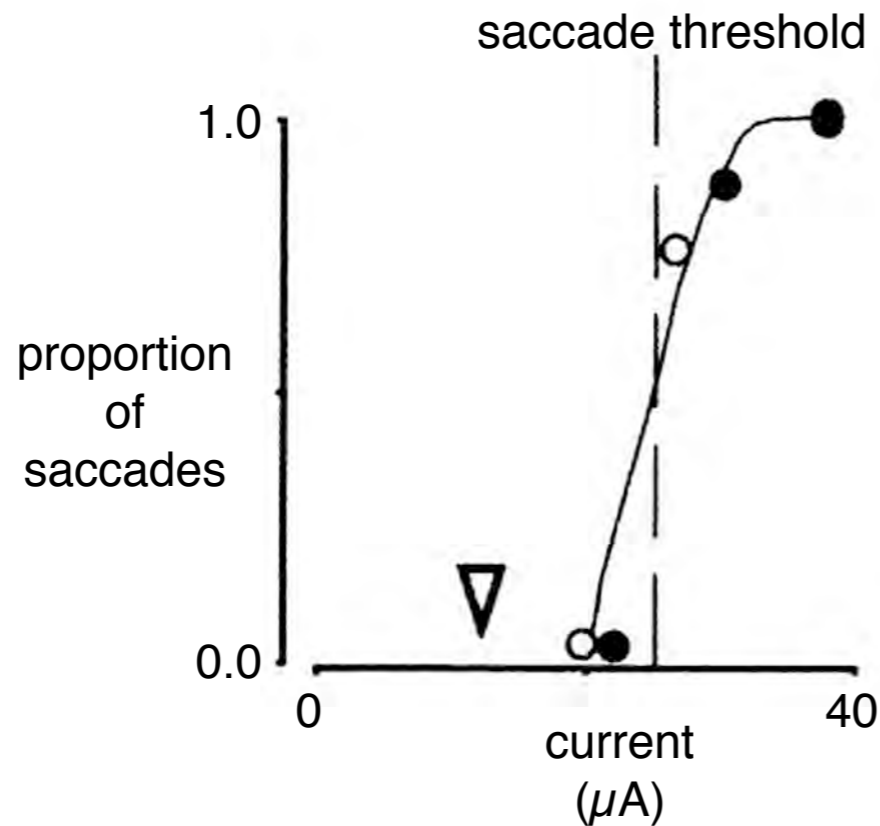
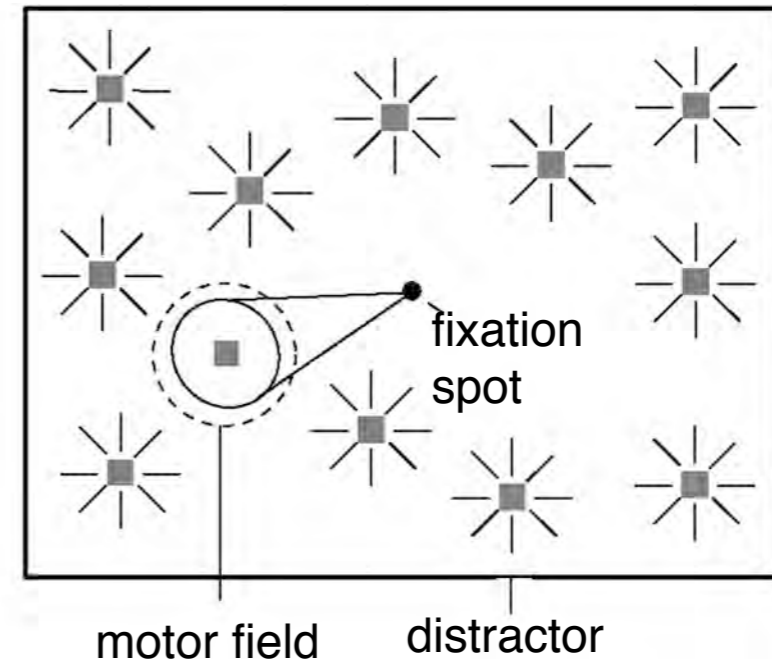
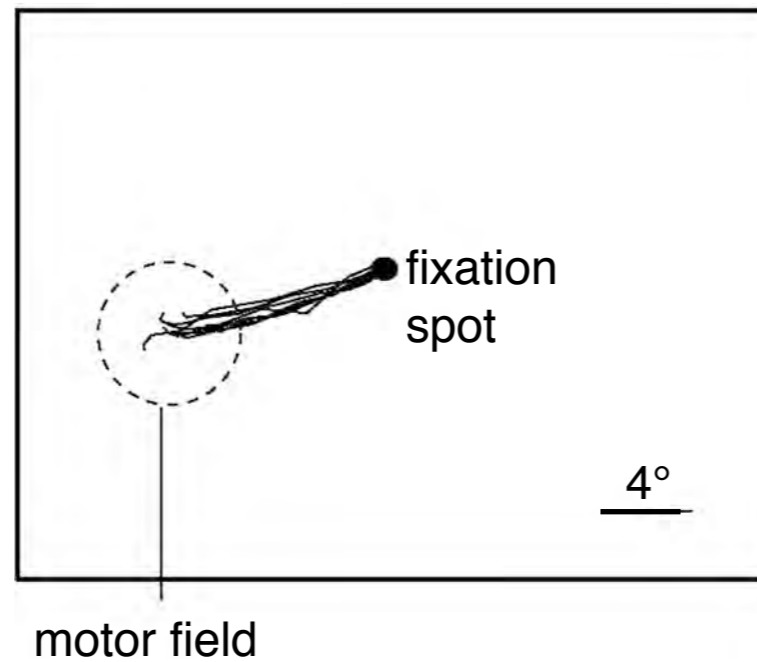

Representative reward and attention tasks

A. Reward size

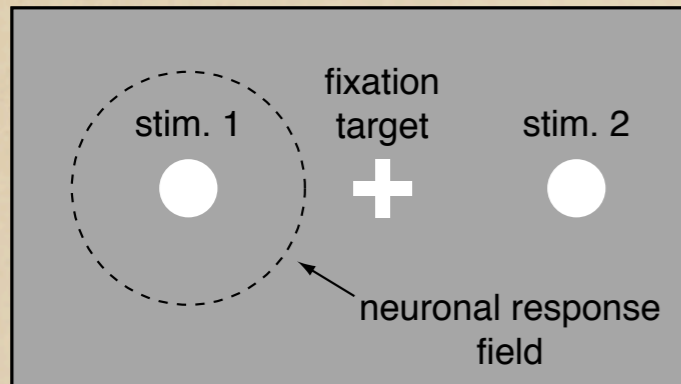

stim. 1 reward		stim. 2 reward		neuronal activity
size	prob.	size	prob.	
8	0.5	2	0.5	high
2	0.5	8	0.5	low

B. Reward probability

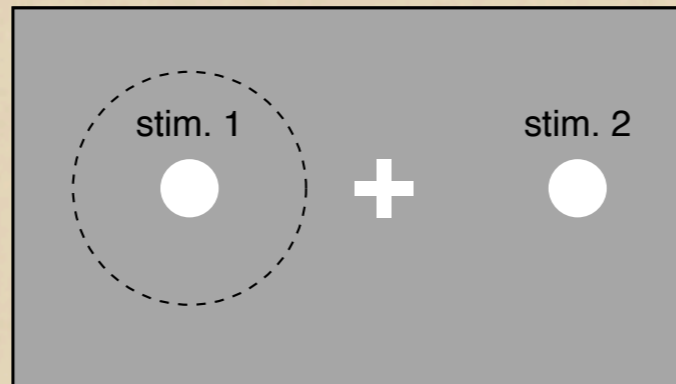

stim. 1 reward		stim. 2 reward		neuronal activity
size	prob.	size	prob.	
5	0.8	5	0.2	high
5	0.2	5	0.8	low

C. Spatial attention

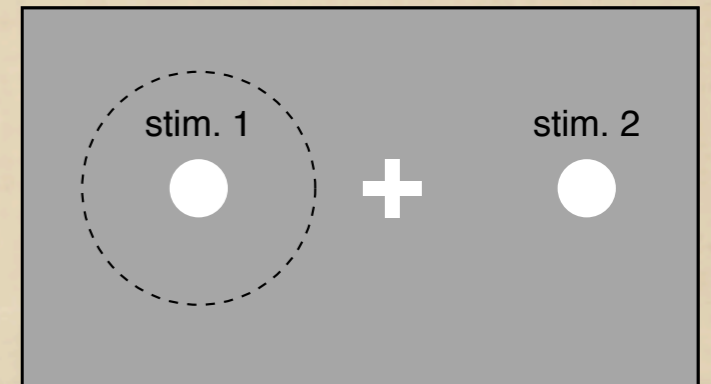

stim. 1 reward		stim. 2 reward		neuronal activity
size	prob.	size	prob.	
5	1.0	0	0.0	high
0	0.0	5	1.0	low